

## Single Pack NLE10CN 115V 60Hz CSIR

Single pack code number: **195B4308**

Position	Title	Code	Amount
1	Compressor NLE10CN	105H6195	1
2	Bolt joint for one compressor   M6   ø16mm	118-1917	1

**Secop GmbH** • Lise-Meitner-Straße 29 • 24941 Flensburg, Germany • Tel: +49 461 4941 0 • [www.secop.com](http://www.secop.com)

---

Secop accepts no responsibility for possible errors in catalogs, brochures, and other printed material. Secop reserves the right to alter its products without notice. This also applies to products already on order provided that such alterations can be made without subsequent changes being necessary to specifications already agreed. All trademarks in this material are the property of the respective companies. Secop and the Secop logotype are trademarks of Secop GmbH. All rights reserved.

---

## Model

Designation	<b>NLE10CN</b>	115V/60Hz 1~	Sales code:	<b>105H6195</b>
-------------	----------------	--------------	-------------	-----------------

## Compressor design

Oil type	Polyolester	Refrigerant(s)	<b>R290</b>
Oil viscosity	32cSt	Displacement	10,09cm <sup>3</sup> / 0,62cu.in
Oil quantity	268cm <sup>3</sup> / 9,1fl.oz	Compressors on pallet	80
Refr. charge - tech. limit	400g / 14,1oz		
Free gas volume comp.	2360cm <sup>3</sup> / 79,8fl.oz		
Weight	10,9kg / 24lbs		
Motor protection	1# internal		
Winding resistance main	1,56Ω (at 25°C)		
Winding resistance aux	4,4Ω (at 25°C)		
Max. winding temp.	125°C / 257°F		
Max. discharge temp.	120°C / 248°F		



## General - Configurations with NLE10CN

	<b>Conf. 1</b>
Motorconfiguration	CSIR
Power supply (nominal)	115V/60Hz
Number of phases	1
Voltage range	103-127V
Approvals	UL
Starting torque	HST
Note	Electrical equipment is included and pre-assembled to compressor.

## Applications with NLE10CN

	<b>Conf. 1</b>
Refrigerant	R290
Application	LBP+MBP
System cooling	fan 3m/s
Hot gas defrost	OK
Long interval pull down	OK

## Electrical data - Configurations with NLE10CN

	<b>Conf. 1</b>
Starting device type	relay
Run capacitor	-/-
Start capacitor	280μF
LRA (locked rotor amps / 4s/ U(N))	34,53A
RLA (rated load amps / 1s/ U(N))	5,6A
Cut in current (U(N))	34,53A

## Model

Designation	<b>NLE10CN</b>	115V/60Hz 1~	Sales code:	<b>105H6195</b>
-------------	----------------	--------------	-------------	-----------------

## Compressor dimensions

<b>Housing</b>	A Height	203mm / 7,99in
	B Height	197mm / 7,76in
	C Length shell	205mm / 8,07in
	D Length w. cover	254mm / 10in
	E Width	166mm / 6,54in

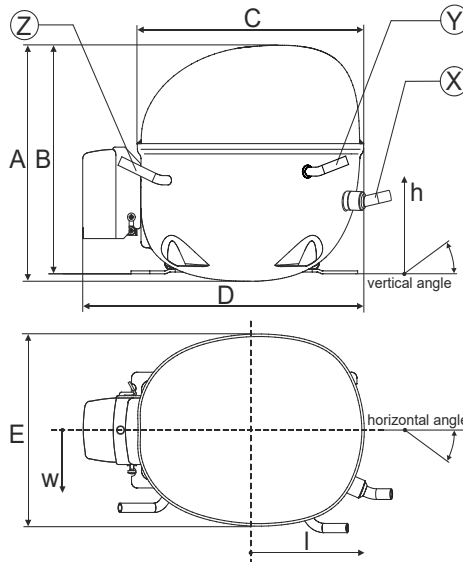

Connectors		Suction	Discharge	Process
		X	Y	Z
Diameter	[mm]	øi 8,11-8,29	øi 6,41-6,59	øi 6,41-6,59
(i:inside, o:outside)	[in]	øi 0,32-0,33	øi 0,25-0,26	øi 0,25-0,26
Material		copper	copper	copper
Horizontal angle	±2°	0°	0°	0°
Vertical angle	±2°	15°	21°	155°
Position l/h/w	[mm]	132/69/57	94/102/81	-109/94/72
	[in]	5,2/2,7/2,2	3,7/4/3,2	-4,3/3,7/2,8
Straight tube l.	[mm]	12	12	12
	[in]	0,5	0,5	0,5

## Compressor fixation

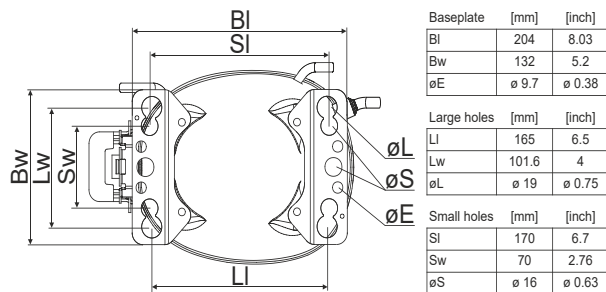

### Bolt joint

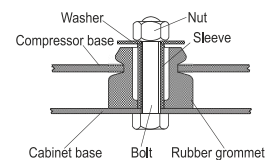

### Snap-on

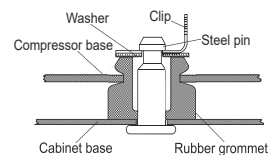

Mounting accessories	one comp.	multi pack
Bolt joint   M6   ø16mm	118-1917	118-1918
Bolt joint   ø1/4"   ø16mm	118-1946	
Bolt joint   ø1/4"   ø19mm	118-1949	
Snap-on   ø7,3   ø16mm	118-1947	118-1919

## #NV

## #NV

Provision for PE Grounding is located at the PE Stamp on the compressor

## Model

Designation	<b>NLE10CN</b>	<b>115V/60Hz</b>	<b>Conf. 1</b>	Sales code:	<b>105H6195</b>
-------------	----------------	------------------	----------------	-------------	-----------------

## Configuration

Motorconfiguration	CSIR	
Power supply (nominal)	115V/60Hz 1~	
Refrigerant	R290	
Application	LBP+MBP	
Voltage range	103-127V	
Starting torque	HST	
Approvals	UL	SA3693

## Electrical accessories / wiring diagram

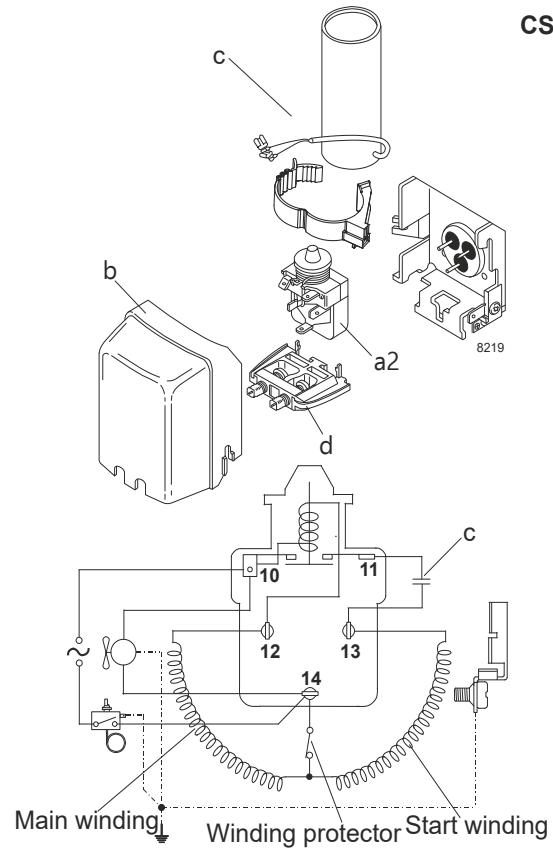

## Ambient/ machine room temperatures minimum /maximum

Ambient temperature range:	10 - 43°C / 50 - 110°F
Machine room temperature range:	10 - 48°C / 50 - 119°F
Compressor cooling:	fan 3m/s

## Operation pressure range

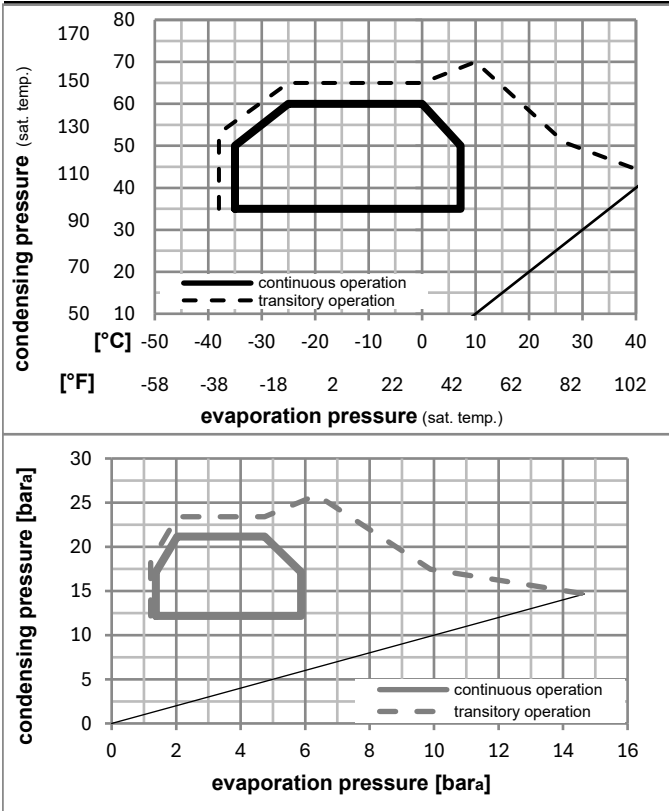

## Components (incl. and pre. assembl.)

a2	current relay	117U7018
c	start capacitor (280µF)	117U5025
b	plastic cover	103N2011
d	cord relief	103N1010

## Model

Designation **NLE10CN** **115V/60Hz** Conf. 1 Sales code: **105H6195**

## Optimization + standard conditions

R290, 115V/60Hz, CSIR, fan 3m/s, UL

		Evaporating pressure (saturation temperature)				Cooling capacity			COP	EER	Power consumption				
		Condensing pressure (saturation temperature)		Return gas temp.	Liquid temp.	[W]	[Btu/h]	[kcal/h]	[W/W]	[Btu/Wh]	[kcal/Wh]	P1	I	Ref. mass flow	
[°C]	[°F]	pe	pc	RGT	Tliq							[W]	[A]	[kg/h]	
[°C]	-23	54	32	32		607,0	2073	522,4	1,52	5,20	1,31	399,0	5,18	6,15	ASHRAE LBP
[°F]	-10	130	90	90											
[°C]	-25	55	32	55		456,4	1559	392,8	1,17	4,00	1,01	389,8	5,13	5,68	cecomaf LBP
[°F]	-13	131	90	131											
[°C]	-35	40	20	40		361,5	1235	311,1	1,26	4,31	1,09	286,2	4,52	4,13	EN12900 LBP
[°F]	-31	104	68	104											
[°C]	-7	54	35	46		1069,4	3652	920,3	2,05	6,99	1,76	522,8	5,95	12,20	ASHRAE MBP
[°F]	20	130	95	115											
[°C]	-10	55	32	55		854,1	2917	735,1	1,70	5,80	1,46	502,8	5,84	10,80	cecomaf MBP
[°F]	14	131	90	131											
[°C]	-10	45	20	45		934,1	3190	803,9	2,04	6,95	1,75	458,8	5,48	11,47	EN12900 MBP
[°F]	14	113	68	113											

## Performance tables

R290, 115V/60Hz, CSIR, fan 3m/s, UL

	pe		Cooling capacity			COP	EER	P1	I	m	
	[°C]	[°F]	[W]	[Btu/h]	[kcal/h]	[W/W]	[Btu/Wh]	[kcal/Wh]	[W]	[A]	[kg/h]
[°C / °F]	-35	-31	339,2	1159	292,0	1,18	4,02	1,01	288,4	4,52	3,80
cond. pressure	-23	-10	575,9	1967	495,6	1,55	5,29	1,33	371,9	5,00	6,50
pc= 45/113	-15	5	807,4	2757	694,8	1,89	6,47	1,63	426,2	5,30	9,19
return gas temp.	-9	15	992,1	3388	853,8	2,15	7,33	1,85	462,5	5,50	11,36
RGT= 32/90	-4	25	1202,1	4105	1034,5	2,40	8,20	2,07	500,4	5,71	13,86
liquid temp	0	32	1364,5	4660	1174,3	2,58	8,82	2,22	528,6	5,87	15,83
Tliq= 45/113	7,2	45	1701,0	5809	1463,9	2,90	9,91	2,50	586,3	6,20	19,99
[°C / °F]	-35	-31	281,6	962	242,4	0,93	3,16	0,80	304,4	4,62	3,48
cond. pressure	-23	-10	492,3	1681	423,7	1,22	4,17	1,05	402,9	5,21	6,14
pc= 55/131	-15	5	702,7	2400	604,7	1,51	5,15	1,30	465,9	5,60	8,83
return gas temp	-9	15	872,1	2978	750,6	1,72	5,88	1,48	507,0	5,86	11,04
RGT= 32/90	-4	25	1065,9	3640	917,3	1,94	6,63	1,67	548,9	6,15	13,60
liquid temp	0	32	1216,5	4155	1046,9	2,10	7,17	1,81	579,5	6,36	15,62
Tliq= 55/131	7,2	45	1529,7	5224	1316,5	2,39	8,15	2,05	640,6	6,80	19,93



# NL Compressors





## Service/Repair – R600a, R290

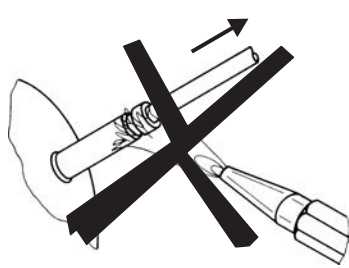

8545

## Brazing on Suction Connectors (Direct Intake)

representative image



**! max. 150°C/302°F !  
at socket**  
brazing solder: phosphor (LP7) or silver

Refer to Product Bulletin:  
**Brazing on Suction Connectors  
(Compressors with Direct Suction Intake)**

Secop accepts no responsibility for possible errors in catalogs, brochures, and other printed material. Secop reserves the right to alter its products without notice. This also applies to products already on order provided that such alterations can be made without subsequential changes being necessary to specifications already agreed. All trademarks in this material are the property of the respective companies. Secop and the Secop logotype are trademarks of Secop GmbH. All rights reserved. [www.secop.com](http://www.secop.com)