

Single Pack SCE15CNLX 115V 60Hz CSCR

Single pack code number: **195B4433**

Position	Title	Code	Amount
1	Compressor SCE15CNLX	104H7578	1
2	SC starting device (600mm)	117-7801	1
3	Bolt joint for one compressor M6 ø16mm	118-1917	1

Secop GmbH • Lise-Meitner-Straße 29 • 24941 Flensburg, Germany • Tel: +49 461 4941 0 • www.secop.com

Secop accepts no responsibility for possible errors in catalogs, brochures, and other printed material. Secop reserves the right to alter its products without notice. This also applies to products already on order provided that such alterations can be made without subsequent changes being necessary to specifications already agreed. All trademarks in this material are the property of the respective companies. Secop and the Secop logotype are trademarks of Secop GmbH. All rights reserved.

Model

Designation	SCE15CNLX	115V/60Hz 1~	Sales code:	104H7578
-------------	------------------	--------------	-------------	-----------------

Compressor design

Oil type	Polyolester	Refrigerant(s)	R290
Oil viscosity	32cSt	Displacement	15,28cm ³ / 0,93cu.in
Oil quantity	569cm ³ / 19,2fl.oz	Compressors on pallet	80
Refr. charge - tech. limit	450g / 15,9oz		
Free gas volume comp.	1460cm ³ / 49,4fl.oz		
Weight	14,2kg / 31,3lbs		
Motor protection	external		
Winding resistance main	0,82Ω (at 25°C)		
Winding resistance aux	2,83Ω (at 25°C)		
Max. winding temp.	125°C / 257°F		
Max. discharge temp.	135°C / 275°F		



General - Configurations with SCE15CNLX

	Conf. 1	Conf. 2	Conf. 3
Motorconfiguration	CSCR	CSCR	CSIR
Power supply (nominal)	115-127V/60Hz	115-127V/60Hz	115-127V/60Hz
Number of phases	1	1	1
Voltage range	103-127V	95-135V	103-127V
Approvals	UL	UL	UL
Starting torque	HST	HST	HST
Note	Protector and cover are included and pre-assembled to compressor.		

Applications with SCE15CNLX

	Conf. 1	Conf. 2	Conf. 3
Refrigerant	R290	R290	R290
Application	LBP	LBP	LBP
System cooling	fan 3m/s	fan 3m/s	fan 3m/s
Hot gas defrost	OK	OK	OK
Long interval pull down	-/-	-/-	-/-

Electrical data - Configurations with SCE15CNLX

	Conf. 1	Conf. 2	Conf. 3
Starting device type	relay	relay	relay
Run capacitor	23,5μF	23,5μF	-/-
Start capacitor	280μF	280μF	280μF
LRA (locked rotor amps / 4s/ U(N))	40,4A	40,4A	39,66A
RLA (rated load amps / 1s/ U(N))	6,85A	6,85A	7,7A
Cut in current (U(N))	40,4A	40,4A	39,66A

Model

Designation	SCE15CNLX	115V/60Hz 1~	Sales code:	104H7578
-------------	------------------	--------------	-------------	-----------------

Compressor dimensions

Housing	A Height	219mm / 8,62in
	B Height	213mm / 8,39in
	C Length shell	218mm / 8,58in
	D Length w. cover	255mm / 10,04in
	E Width	151mm / 5,94in

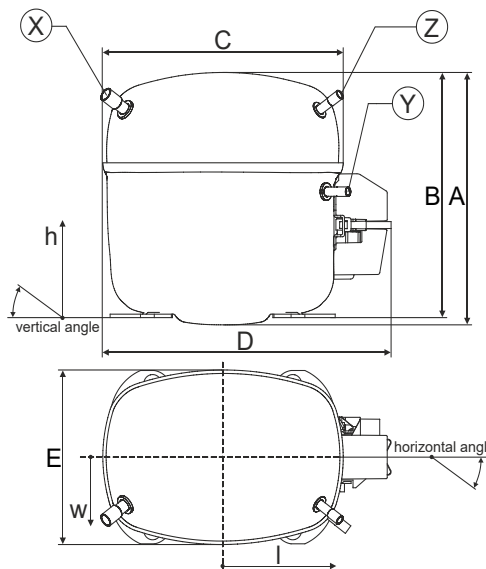

Connectors		Suction	Discharge	Process
		X	Y	Z
Diameter	[mm]	øi 9,54-9,72	øi 6,41-6,59	øi 6,41-6,59
	(i:inside, o:outside) [in]	øi 0,38-0,38	øi 0,25-0,26	øi 0,25-0,26
Material		copper	copper	copper
Horizontal angle	±2°	37°	37°	143°
Vertical angle	±2°	30°	0°	150°
Position l/h/w	[mm]	107/193/55	115/110/63	-107/193/55
	[in]	4,2/7,6/2,2	4,5/4,3/2,5	-4,2/7,6/2,2
Straight tube l.	[mm]	12	12	12
	[in]	0,5	0,5	0,5

Compressor fixation

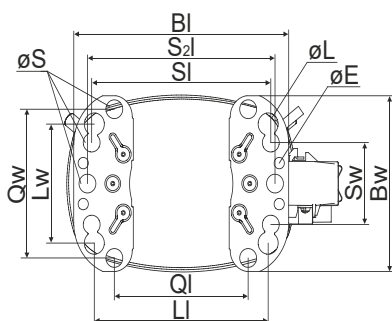

Baseplate	[mm]	[inch]
BI	204	8.03
Bw	150	5.9
øE	ø 9.7	ø 0.38
Large holes		
LI	165	6.5
Lw	101.6	4
øL	ø 19	ø 0.75
Small holes		
SI	170	6.7
Sw	70	2.76
øS	ø 16	ø 0.63
QI	127	5
Qw	127	5

Bolt joint

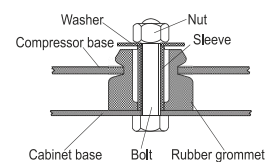

Snap-on

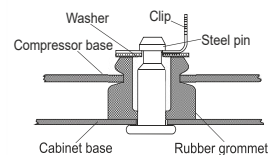

Mounting accessories

	one comp.	multi pack
Bolt joint M6 ø16mm	118-1917	118-1918
Bolt joint ø1/4" ø16mm	118-1946	
Bolt joint ø1/4" ø19mm	118-1949	
Snap-on ø7,3 ø16mm	118-1947	118-1919

Application notes

Provision for PE Grounding is located at the PE Stamp on the compressor

Model

Designation	SCE15CNLX	115-127V/60Hz	Conf. 1	Sales code:	104H7578
-------------	------------------	----------------------	----------------	-------------	-----------------

Configuration

Motor configuration	CSCR
Power supply (nominal)	115-127V/60Hz 1~
Refrigerant	R290
Application	LBP
Voltage range	103-127V
Starting torque	HST
Approvals	UL

Electrical accessories / wiring diagram



Ambient/ machine room temperatures minimum /maximum

Ambient temperature range:	10 - 43°C / 50 - 110°F
Machine room temperature range:	10 - 48°C / 50 - 119°F
Compressor cooling:	fan 3m/s

Operation pressure range

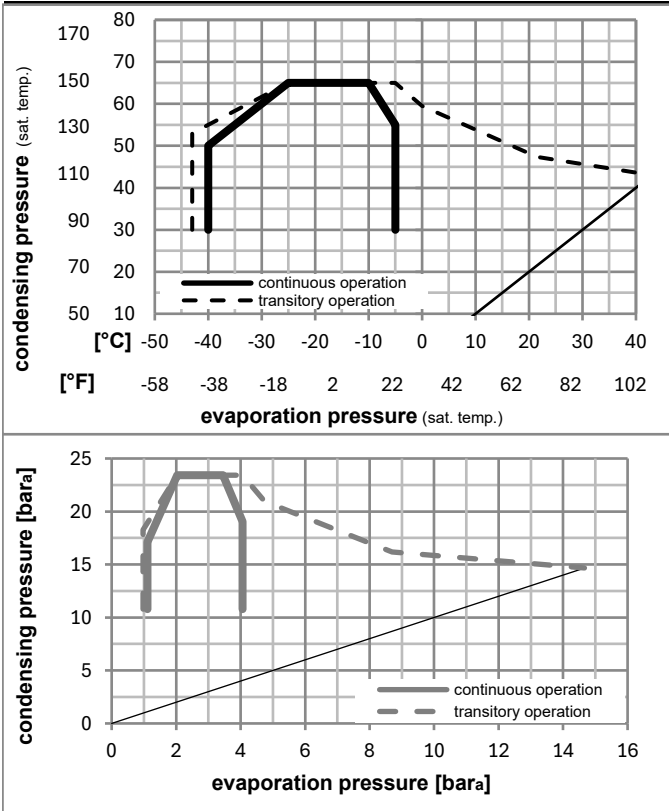

Components (protector (f)+ holder (h)+ cover (b): pre assembled)

a3	SC starter kit (550mm)	117-7801
h	protector holder	117U0439
f	ext. protector (T1101)	117U3218
b	plastic cover + clamp	117U1021

Alternative comp.

a2	potential relay (RVA 7AA3R)	117-7441
e	run capacitor (23,5μF, 6.3mm)	117-7133
c	start capacitor (280μF, 6.3mm)	117U5350

Model

Designation **SCE15CNLX 115-127V/60Hz** Conf. 1 Sales code: **104H7578**

Optimization + standard conditions

R290, 115V/60Hz, CSCR, fan 3m/s, UL

	pe	pc	RGT	Tliq	Cooling capacity	COP	EER	P1	I	Ref. mass flow	
	[°C]	[°C]	[°C]	[°C]	[W]	[W/W]	[Btu/Wh]	[W]	[A]	[kg/h]	
	[°F]	[°F]	[°F]	[°F]	[Btu/h]	[kcal/h]	[kcal/Wh]	[W]	[A]	[kg/h]	
ASHRAE LBP	-23	54	32	32	799,7	1,58	5,38	507,4	4,90	8,10	
	-10	130	90	90			1,36				
cecomaf LBP	-25	55	32	55	583,1	1,22	4,15	479,5	4,70	7,26	
	-13	131	90	131			1,05				
EN12900 LBP	-35	40	20	40	403,0	1,18	4,03	341,6	3,67	4,60	
	-31	104	68	104			1,02				
ARI540 LBP	-23	49	4,4	49	664,6	1,33	4,54	500,4	4,78	9,20	
	-10	120	40	120			1,14				
AHAM LBP	-23	41	32	32	915,5	1,91	6,51	480,3	4,60	9,27	
	-10	105	90	90			1,64				
opt	-35	45	32	45	347,6	1,05	3,59	330,9	3,56	3,89	
	-31	113	90	113			0,90				

Performance tables

R290, 115V/60Hz, CSCR, fan 3m/s, UL

	pe	Cooling capacity			COP	EER	P1	I	m		
	[°C]	[°F]	[W]	[Btu/h]	[kcal/h]	[W/W]	[Btu/Wh]	[kcal/Wh]	[W]	[A]	[kg/h]
[°C / °F]	-40	-40	172,4	589	148,4	0,70	2,38	0,60	247,6	3,07	1,93
cond. pressure	-34	-30	367,3	1254	316,1	1,08	3,69	0,93	339,6	3,61	4,12
pc= 45/113	-29	-20	569,7	1946	490,3	1,35	4,62	1,17	420,8	4,16	6,41
return gas temp.	-23	-10	787,7	2690	677,9	1,60	5,48	1,38	491,3	4,69	8,89
RGT= 32/90	-21	-5	905,0	3091	778,9	1,73	5,91	1,49	522,7	4,94	10,24
liquid temp	-15	5	1161,3	3966	999,4	2,01	6,86	1,73	577,8	5,42	13,21
Tliq= 45/113	-5	23	1717,5	5865	1478,1	2,63	8,99	2,27	652,2	6,15	19,77
[°C / °F]	-40	-40	48,9	167	42,1	0,28	0,97	0,25	171,6	2,63	0,60
cond. pressure	-34	-30	244,7	836	210,6	0,82	2,81	0,71	297,6	3,42	3,03
pc= 55/131	-29	-20	441,1	1506	379,6	1,08	3,68	0,93	409,5	4,18	5,48
return gas temp	-23	-10	645,9	2206	555,9	1,27	4,35	1,10	507,4	4,91	8,05
RGT= 32/90	-21	-5	754,0	2575	648,9	1,37	4,67	1,18	551,3	5,25	9,43
liquid temp	-15	5	986,6	3369	849,0	1,57	5,36	1,35	628,9	5,89	12,40
Tliq= 55/131	-5	23	1482,1	5062	1275,5	2,02	6,88	1,73	735,4	6,83	18,88

Model

Designation	SCE15CNLX	115-127V/60Hz	Conf. 2	Sales code:	104H7578
-------------	------------------	----------------------	----------------	-------------	-----------------

Configuration

Motor configuration	CSCR
Power supply (nominal)	115-127V/60Hz 1~
Refrigerant	R290
Application	LBP
Voltage range	95-135V
Starting torque	HST
Approvals	UL

Electrical accessories / wiring diagram

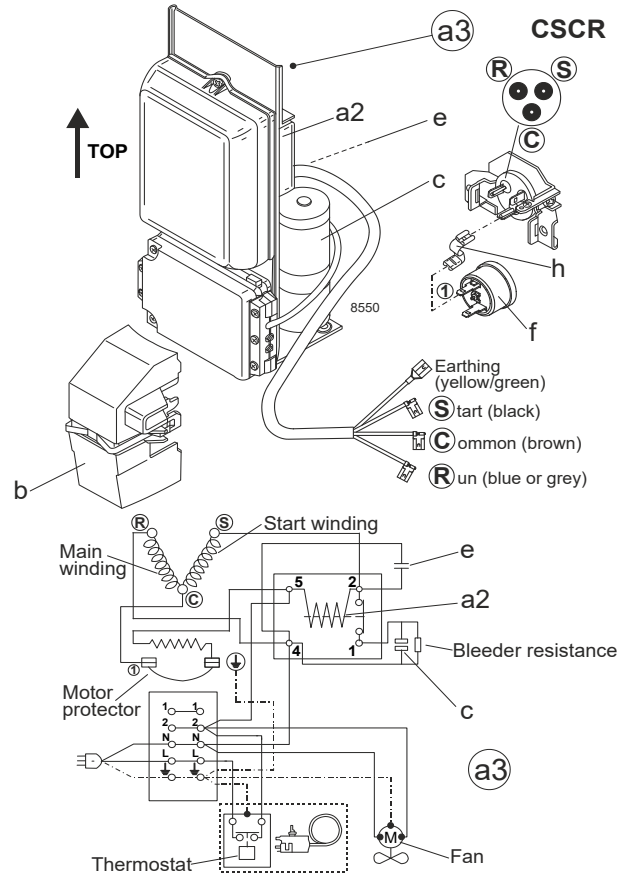

Ambient/ machine room temperatures minimum /maximum

Ambient temperature range:	10 - 43°C / 50 - 110°F
Machine room temperature range:	10 - 48°C / 50 - 119°F
Compressor cooling:	fan 3m/s

Operation pressure range

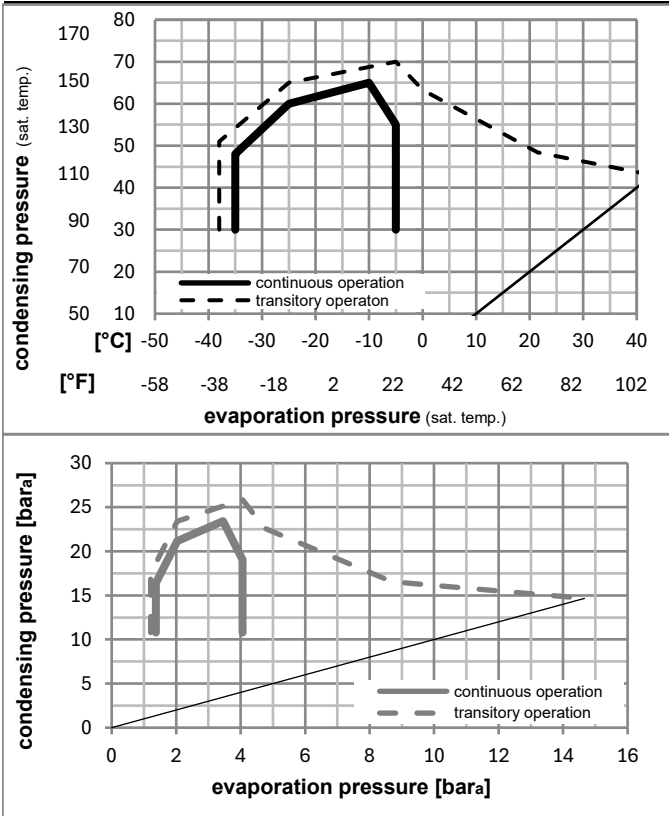

Components (protector (f)+ holder (h)+ cover (b): pre assembled)

a3	SC starter kit (550mm)	117-7801
h	protector holder	117U0439
f	ext. protector (T1101)	117U3218
b	plastic cover + clamp	117U1021

Alternative comp.

a2	potential relay (RVA 7AA3R)	117-7441
e	run capacitor (23,5μF, 6.3mm)	117-7133
c	start capacitor (280μF, 6.3mm)	117U5350

Model

Designation **SCE15CNLX 115-127V/60Hz** Conf. 2 Sales code: **104H7578**

Optimization + standard conditions

R290, 115V/60Hz, CSCR, fan 3m/s, UL

	Evaporating pressure (saturation temperature)				Cooling capacity	COP	EER	Power consumption			ASHRAE LBP			
	pe	pc	RGT	Tliq				P1	I	m				
	[°C]	[°F]	[°C]	[°F]	[W]	[Btu/h]	[kcal/h]	[W/W]	[Btu/Wh]	[kcal/Wh]	[W]	[A]	[kg/h]	
	-23	54	32	32	799,7	2731	688,2	1,58	5,38	1,36	507,4	4,90	8,10	ASHRAE LBP
	-10	130	90	90										
	-25	55	32	55	583,1	1991	501,8	1,22	4,15	1,05	479,5	4,70	7,26	cecomaf LBP
	-13	131	90	131										
	-35	40	20	40	403,0	1376	346,8	1,18	4,03	1,02	341,6	3,67	4,60	EN12900 LBP
	-31	104	68	104										
	-23	49	4,4	49	664,6	2270	572,0	1,33	4,54	1,14	500,4	4,78	9,20	ARI540 LBP
	-10	120	40	120										
	-23	41	32	32	915,5	3127	787,9	1,91	6,51	1,64	480,3	4,60	9,27	AHAM LBP
	-10	105	90	90										
	-35	45	32	45	347,6	1187	299,1	1,05	3,59	0,90	330,9	3,56	3,89	opt
	-31	113	90	113										

Performance tables

R290, 115V/60Hz, CSCR, fan 3m/s, UL

	pe		Cooling capacity			COP	EER	P1	I	m	
	[°C]	[°F]	[W]	[Btu/h]	[kcal/h]	[W/W]	[Btu/Wh]				[kcal/Wh]
[°C / °F]	-35	-31	347,6	1187	299,1	1,05	3,59	0,90	330,9	3,56	3,89
cond. pressure	-29	-20	569,7	1946	490,3	1,35	4,62	1,17	420,8	4,16	6,41
pc= 45/113	-26	-15	676,2	2309	582,0	1,48	5,05	1,27	457,3	4,42	7,62
return gas temp.	-23	-10	787,7	2690	677,9	1,60	5,48	1,38	491,3	4,69	8,89
RGT= 32/90	-21	-5	905,0	3091	778,9	1,73	5,91	1,49	522,7	4,94	10,24
liquid temp	-15	5	1161,3	3966	999,4	2,01	6,86	1,73	577,8	5,42	13,21
Tliq= 45/113	-5	23	1717,5	5865	1478,1	2,63	8,99	2,27	652,2	6,15	19,77
[°C / °F]	-35	-31	225,2	769	193,8	0,79	2,69	0,68	285,7	3,34	2,78
cond. pressure	-29	-20	441,1	1506	379,6	1,08	3,68	0,93	409,5	4,18	5,48
pc= 55/131	-26	-15	541,9	1851	466,4	1,18	4,02	1,01	460,2	4,55	6,74
return gas temp	-23	-10	645,9	2206	555,9	1,27	4,35	1,10	507,4	4,91	8,05
RGT= 32/90	-21	-5	754,0	2575	648,9	1,37	4,67	1,18	551,3	5,25	9,43
liquid temp	-15	5	986,6	3369	849,0	1,57	5,36	1,35	628,9	5,89	12,40
Tliq= 55/131	-5	23	1482,1	5062	1275,5	2,02	6,88	1,73	735,4	6,83	18,88

Model

Designation	SCE15CNLX	115-127V/60Hz	Conf. 3	Sales code:	104H7578
-------------	------------------	----------------------	----------------	-------------	-----------------

Configuration

Motor configuration	CSIR
Power supply (nominal)	115-127V/60Hz 1~
Refrigerant	R290
Application	LBP
Voltage range	103-127V
Starting torque	HST
Approvals	UL

Electrical accessories / wiring diagram

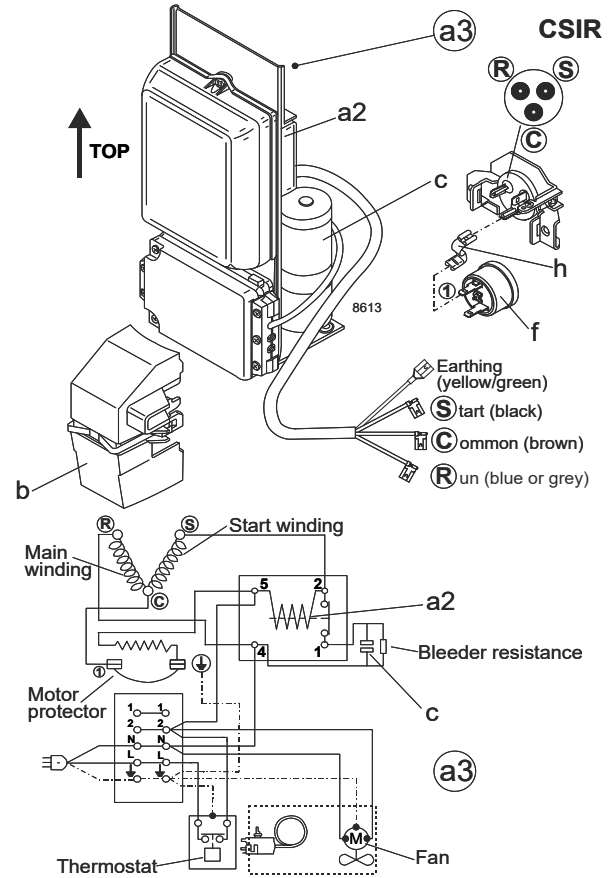

Ambient/ machine room temperatures minimum /maximum

Ambient temperature range:	10 - 43°C / 50 - 110°F
Machine room temperature range:	10 - 48°C / 50 - 119°F
Compressor cooling:	fan 3m/s

Operation pressure range

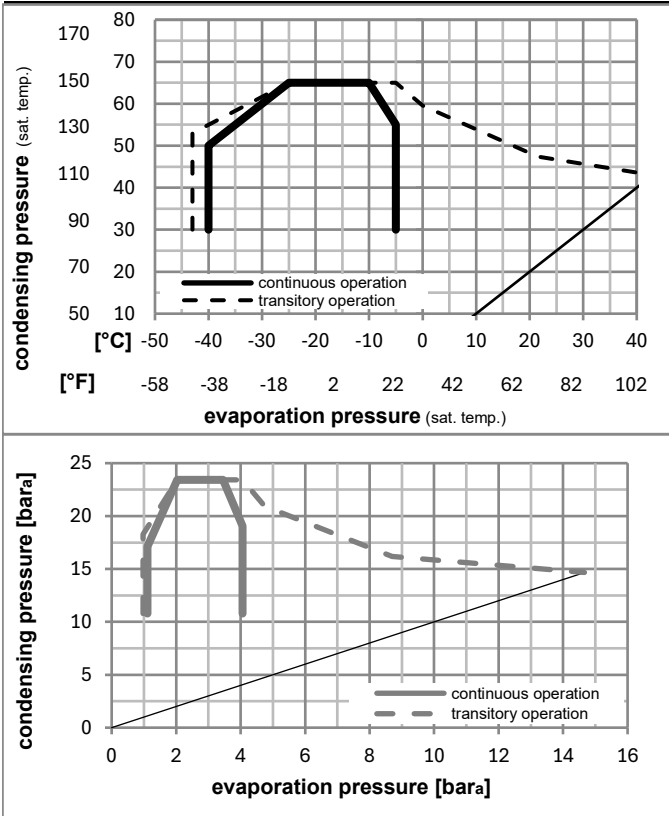

Components (protector (f)+ holder (h)+ cover (b): pre assembled)

a3	SC starter kit (550mm)	117-7802
h	protector holder	117U0439
f	ext. protector (T1101)	117U3218
b	plastic cover + clamp	117U1021

Alternative comp.

a2	potential relay (RVA 7AA3R)	117-7441
c	start capacitor (280µF, 6.3mm)	117U5350

Model

Designation **SCE15CNLX 115-127V/60Hz** Conf. 3 Sales code: **104H7578**

Optimization + standard conditions

R290, 115V/60Hz, CSIR, fan 3m/s, UL

	Evaporating pressure (saturation temperature)				Cooling capacity	COP	EER	Power consumption			ASHRAE LBP			
	pe	pc	RGT	Tliq				P1	I	m				
	[°C]	[°F]	[°C]	[°F]	[W]	[Btu/h]	[kcal/h]	[W/W]	[Btu/Wh]	[kcal/Wh]	[W]	[A]	[kg/h]	
	-23	54	32	32	797,2	2722	686,1	1,50	5,12	1,29	532,1	6,20	8,07	ASHRAE LBP
	-10	130	90	90										
	-25	55	32	55	581,4	1985	500,3	1,16	3,95	1,00	502,6	6,00	7,24	cecomaf LBP
	-13	131	90	131										
	-35	40	20	40	401,8	1372	345,8	1,12	3,84	0,97	357,3	4,97	4,59	EN12900 LBP
	-31	104	68	104										
	-23	49	4,4	49	662,5	2263	570,2	1,26	4,31	1,09	525,0	6,12	9,18	ARI540 LBP
	-10	120	40	120										
	-23	41	32	32	912,6	3117	785,4	1,81	6,17	1,55	505,3	5,93	9,24	AHAM LBP
	-10	105	90	90										
	-35	45	32	45	346,5	1183	298,2	1,00	3,43	0,86	345,2	4,91	3,88	opt
	-31	113	90	113										

Performance tables

R290, 115V/60Hz, CSIR, fan 3m/s, UL

	pe		Cooling capacity			COP	EER	P1	I	m	
	[°C]	[°F]	[W]	[Btu/h]	[kcal/h]	[W/W]	[Btu/Wh]	[kcal/Wh]	[W]	[A]	[kg/h]
[°C / °F]	-40	-40	171,7	586	147,8	0,67	2,30	0,58	255,4	4,36	1,92
cond. pressure	-34	-30	366,2	1251	315,1	1,03	3,53	0,89	354,5	4,97	4,10
pc= 45/113	-29	-20	568,0	1940	488,8	1,29	4,40	1,11	441,3	5,53	6,39
return gas temp.	-23	-10	785,2	2682	675,8	1,52	5,20	1,31	516,2	6,03	8,87
RGT= 32/90	-21	-5	902,1	3081	776,3	1,64	5,61	1,41	549,3	6,26	10,21
liquid temp	-15	5	1157,3	3952	996,0	1,91	6,51	1,64	607,2	6,68	13,17
Tliq= 45/113	-5	23	1710,9	5843	1472,4	2,50	8,54	2,15	684,5	7,28	19,70
[°C / °F]	-40	-40	48,9	167	42,1	0,28	0,96	0,24	173,6	3,90	0,60
cond. pressure	-34	-30	244,3	834	210,3	0,79	2,70	0,68	308,8	4,74	3,02
pc= 55/131	-29	-20	440,0	1503	378,6	1,03	3,51	0,88	428,2	5,51	5,46
return gas temp	-23	-10	643,9	2199	554,1	1,21	4,13	1,04	532,2	6,20	8,03
RGT= 32/90	-21	-5	751,4	2566	646,7	1,30	4,44	1,12	578,6	6,52	9,39
liquid temp	-15	5	982,7	3356	845,7	1,49	5,08	1,28	660,5	7,11	12,35
Tliq= 55/131	-5	23	1475,2	5038	1269,6	1,91	6,52	1,64	772,3	7,97	18,79

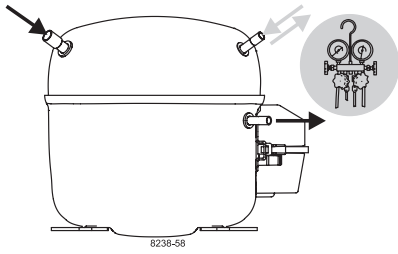

SCE Compressors

(External Protector)

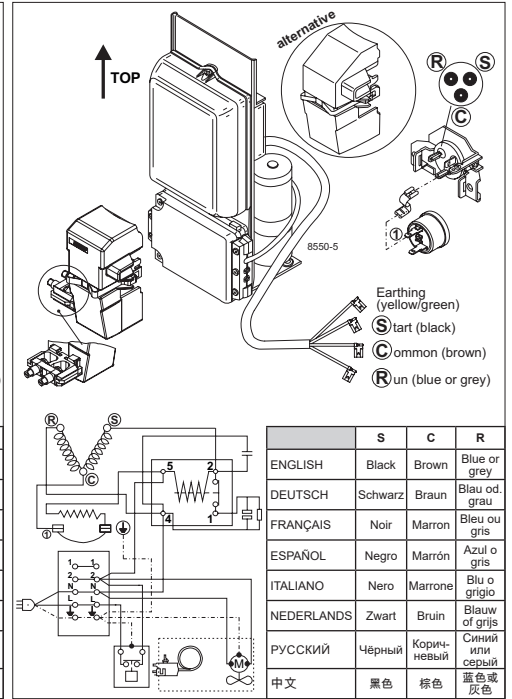
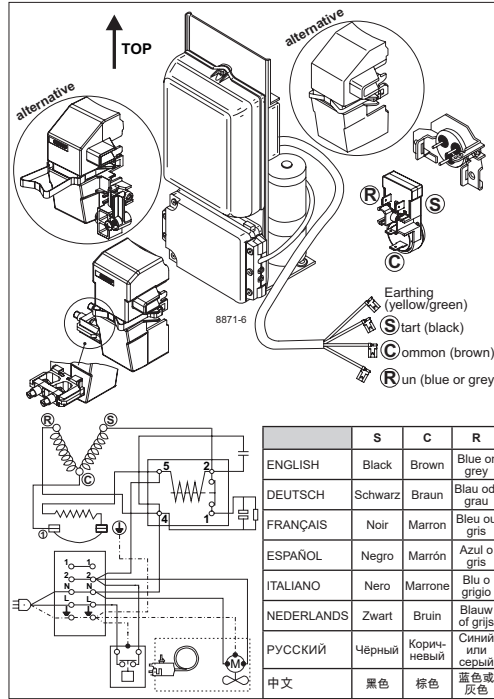
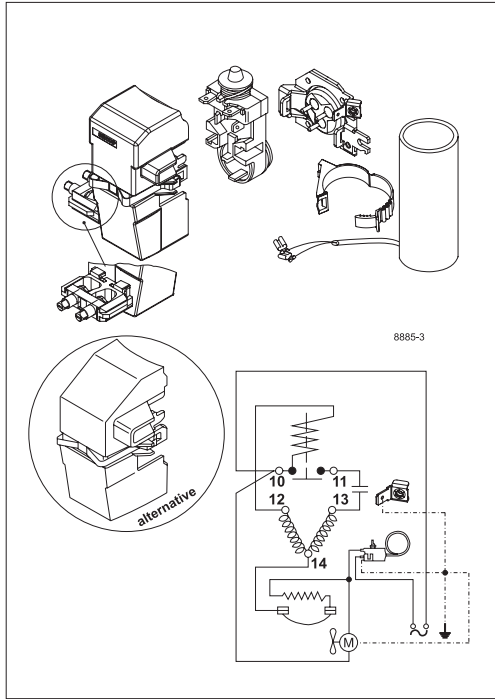
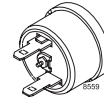

	S	C	R
ENGLISH	Black	Brown	Blue or grey
DEUTSCH	Schwarz	Braun	Blau od. grau
FRANÇAIS	Noir	Marron	Bleu ou gris
ESPAÑOL	Negro	Marrón	Azul o gris
ITALIANO	Nero	Marrone	Blu o grigio
NEDERLANDS	Zwart	Bruin	Blauw of grijs
РУССКИЙ	Чёрный	Коричневый	Синий или серый
中文	黑色	棕色	蓝色或灰色

	S	C	R
ENGLISH	Black	Brown	Blue or grey
DEUTSCH	Schwarz	Braun	Blau od. grau
FRANÇAIS	Noir	Marron	Bleu ou gris
ESPAÑOL	Negro	Marrón	Azul o gris
ITALIANO	Nero	Marrone	Blu o grigio
NEDERLANDS	Zwart	Bruin	Blauw of grijs
РУССКИЙ	Чёрный	Коричневый	Синий или серый
中文	黑色	棕色	蓝色或灰色

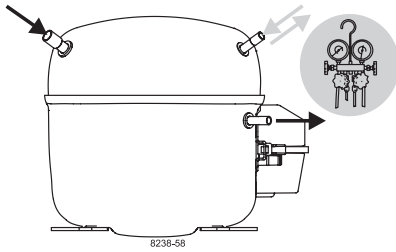

SCE Compressors (External Protector)



Service/Repair – R290

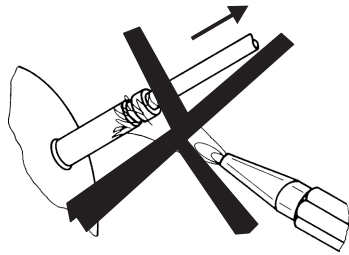

8545

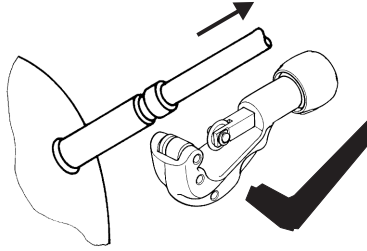

Brazing on Suction Connectors (Direct Intake)

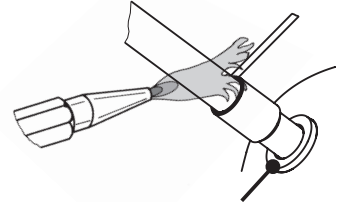

! max. 350°C/662°F !
at socket
 brazing solder: phosphor (LP7) or silver

8882

Refer to Product Bulletin:
Brazing on Suction Connectors
(SCE Compressors with Direct Suction Intake)

Secop accepts no responsibility for possible errors in catalogs, brochures, and other printed material. Secop reserves the right to alter its products without notice. This also applies to products already on order provided that such alterations can be made without subsequential changes being necessary to specifications already agreed. All trademarks in this material are the property of the respective companies. Secop and the Secop logotype are trademarks of Secop GmbH. All rights reserved. www.secop.com