

Single Pack NL8F 220-240V 50Hz CSIR

Single pack code number: **195B4469**

Position	Title	Code	Amount
1	Compressor NL8F	105G6822	1
2	Starting relay	117U6001	1
3	Starting capacitor (80 μ F 220V, 6.3mm)	117U5015	1
4	Cord relief	103N1010	1
5	Cover	103N2010	1
6	Bolt joint for one compressor M6 \varnothing 16mm	118-1917	1

Secop GmbH • Lise-Meitner-Straße 29 • 24941 Flensburg, Germany • Tel: +49 461 4941 0 • www.secop.com

Secop accepts no responsibility for possible errors in catalogs, brochures, and other printed material. Secop reserves the right to alter its products without notice. This also applies to products already on order provided that such alterations can be made without subsequent changes being necessary to specifications already agreed. All trademarks in this material are the property of the respective companies. Secop and the Secop logotype are trademarks of Secop GmbH. All rights reserved.

Model

Designation	NL8F	220-240V/50Hz 1~	Sales code:	105G6822
-------------	-------------	-------------------------	-------------	-----------------

Compressor design

Oil type	Polyolester	Refrigerant(s)	R134a
Oil viscosity	19,2cST	Displacement	7,95cm ³ / 0,49cu.in
Oil quantity	265cm ³ / 9fl.oz	Compressors on pallet	80
Refr. charge - tech. limit	400g / 14,1oz		
Free gas volume comp.	2230cm ³ / 75,4fl.oz		
Weight	9,8kg / 21,6lbs		
Motor protection	1# internal		
Winding resistance main	10,7Ω (at 25°C)		
Winding resistance aux	13Ω (at 25°C)		
Max. winding temp.	125°C / 257°F		
Max. discharge temp.	130°C / 266°F		



General - Configurations with NL8F

	Conf. 1	Conf. 2
Motorconfiguration	CSIR	RSIR
Power supply (nominal)	220-240V/50Hz	220-240V/50Hz
Number of phases	1	1
Voltage range	198-254V	198-254V
Approvals	VDE, EAC	VDE, EAC
Starting torque	HST	LST
Note	- / -	

Applications with NL8F

	Conf. 1	Conf. 2
Refrigerant	R134a	R134a
Application	LBP	LBP
System cooling	static	static
Hot gas defrost	- / -	- / -
Long interval pull down	- / -	- / -

Electrical data - Configurations with NL8F

	Conf. 1	Conf. 2
Starting device type	relay	PTC
Run capacitor	- / -	- / -
Start capacitor	80μF	- / -
LRA (locked rotor amps / 4s)	6,6A	7,9A
RLA (rated load amps / 1s)		
Cut in current	10,9A	7,9A

Model

Designation	NL8F	220-240V/50Hz 1~	Sales code:	105G6822
-------------	-------------	------------------	-------------	-----------------

Compressor dimensions

Housing	A Height	197mm / 7,76in
	B Height	191mm / 7,52in
	C Length shell	205mm / 8,07in
	D Length w. cover	254mm / 10in
	E Width	166mm / 6,54in

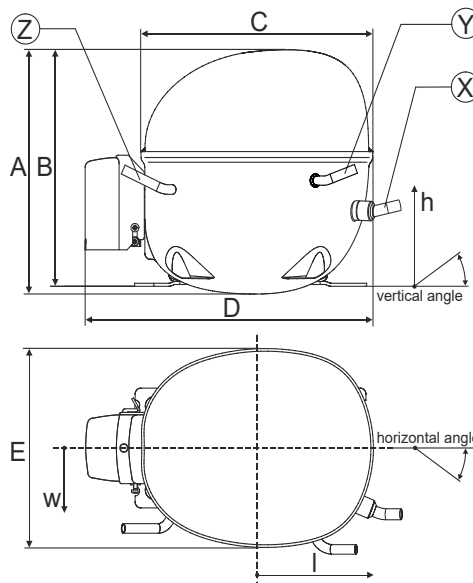

Connectors		Suction	Discharge	Process
		X	Y	Z
Diameter	[mm]	øi 6,11-6,29	øi 5,12-5,22	øi 6,11-6,29
(i:inside, o:outside)	[in]	øi 0,24-0,25	øi 0,2-0,21	øi 0,24-0,25
Material		copper	copper	copper
Horizontal angle	±2°	0°	0°	0°
Vertical angle	±2°	15°	35°	155°
Position l/h/w	[mm]	126/76/78	133/103/54	-107/94/72
	[in]	4,9/3/3,1	5,2/4/2,1	-4,2/3,7/2,8
Straight tube l.	[mm]	12	12	12
	[in]	0,5	0,5	0,5

Compressor fixation

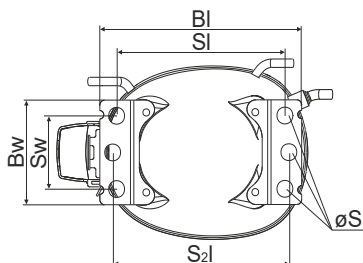

Baseplate	[mm]	[inch]
Bi	204	8.03
Bw	100	3.94

Small holes	[mm]	[inch]
Si	170	6.7
Sw	70	2.76
S2l	178	7
øS	ø 16	ø 0.63

Bolt joint

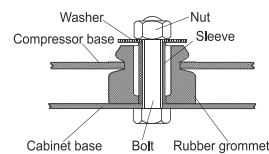

Snap-on

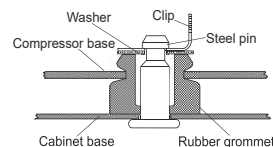

Mounting accessories	one comp.	multi pack
Bolt joint M6 ø16mm	118-1917	118-1918
Bolt joint ø1/4" ø16mm	118-1946	
Bolt joint ø1/4" ø19mm	118-1949	
Snap-on ø7,3 ø16mm	118-1947	118-1919

Model

Designation	NL8F	220-240V/50Hz	Conf. 1	Sales code:	105G6822
-------------	-------------	----------------------	----------------	-------------	-----------------

Configuration

Motorconfiguration	CSIR
Power supply (nominal)	220-240V/50Hz 1~
Refrigerant	R134a
Application	LBP
Voltage range	198-254V
Starting torque	HST
Approvals	VDE EAC

Electrical accessories / wiring diagram

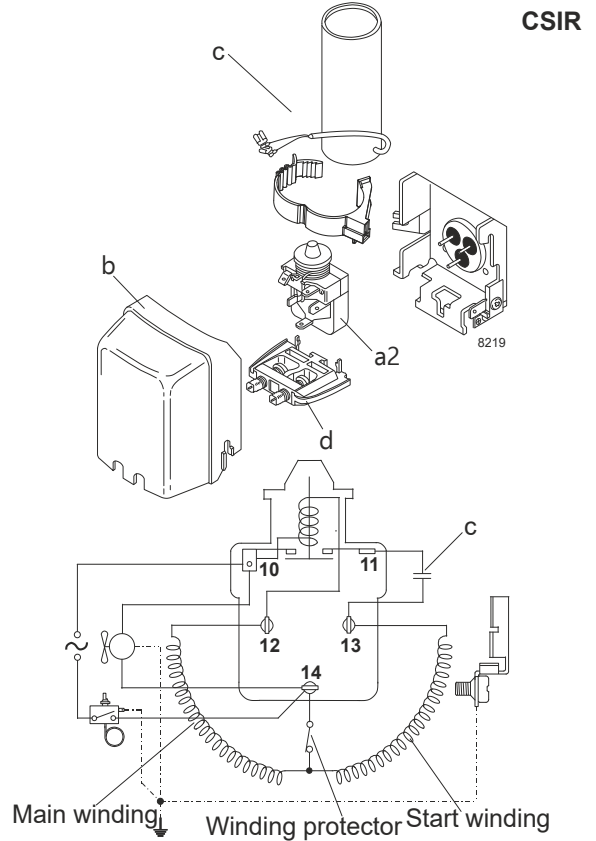

Ambient temperatures / system cooling

Ambient temperature min.:	10°C / 50°F
Ambient temperature max.:	38°C / 101°F

System cooling (n/a: outside limits)			
T ambient	LBP	MBP	HBP
32°C / 90°F	static	n/a	n/a
38°C / 100°F	static	n/a	n/a
43°C / 110°F	n/a	n/a	n/a

Operation pressure range

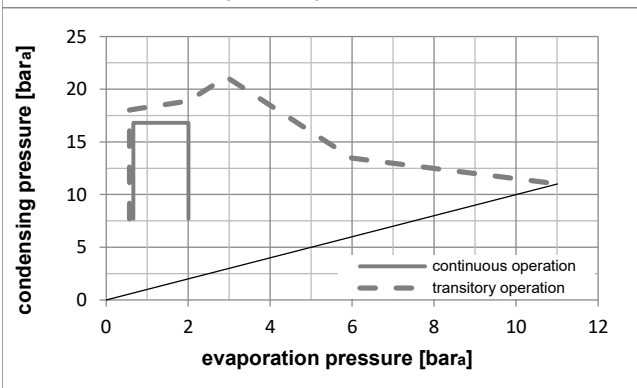
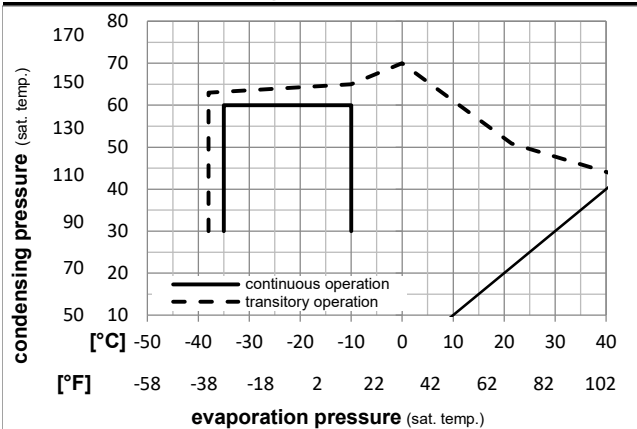

Components

a2	current relay	117U6001
c	start capacitor (80µF)	117U5015
b	plastic cover	103N2010
d	cord relief	103N1010

Alternative components

b	plastic cover	103N2011
---	---------------	----------

Model

Designation	NL8F	220-240V/50Hz	Conf. 1	Sales code:	105G6822
-------------	-------------	----------------------	----------------	-------------	-----------------

Optimization + standard conditions

R134a, 220V/50Hz, CSIR, static, VDE, EAC

		Evaporating pressure (saturation temperature)				Condensing pressure (saturation temperature)						Power consumption			
		Return gas temp.				Liquid temp.						Current consumption			Ref. mass flow
		Cooling capacity				COP		EER		P1	I	m			
		pe	pc	RGT	Tliq	[W]	[Btu/h]	[kcal/h]	[W/W]	[Btu/Wh]	[kcal/Wh]	[W]	[A]	[kg/h]	
[°C]	-23,3	54,4	32,2	32,2	200,2	684	172,3	1,24	4,25	1,07	161,0	1,06	3,89	ASHRAE LBP	
[°F]	-10	130	90	90											
[°C]	-25	55	32	55	149,0	509	128,3	0,97	3,30	0,83	154,1	1,04	3,56	cecomaf LBP	
[°F]	-13	131	89,6	131											
[°C]	-35	40	20	40	109,0	372	93,8	0,95	3,23	0,81	115,1	0,93	2,39	EN12900 LBP	
[°F]	-31	104	68	104											
[°C]	-23,3	48,9	4,44	48,9	161,8	553	139,3	1,03	3,52	0,89	157,2	1,04	4,27	ARI540 LBP	
[°F]	-10	120	40	120											
[°C]	-23,3	40,6	32,2	32,2	223,8	764	192,6	1,45	4,96	1,25	154,1	1,06	4,35	AHAM LBP	
[°F]	-10	105	90	90											
[°C]	-35	45	32	45	99,8	341	85,9	0,87	2,96	0,75	115,0	0,92	2,15	opt	
[°F]	-31	113	89,6	113											

Performance tables

R134a, 220V/50Hz, CSIR, static, VDE, EAC

	pe		Cooling capacity			COP		EER		P1	I	m
	[°C]	[°F]	[W]	[Btu/h]	[kcal/h]	[W/W]	[Btu/Wh]	[kcal/Wh]	[W]	[A]	[kg/h]	
[°C / °F]	-35	-31	99,8	341	85,9	0,87	2,96	0,75	115,0	0,92	2,15	
cond. pressure	-30	-22	133,7	457	115,1	1,02	3,49	0,88	131,0	0,97	2,89	
pc= 45/113	-25	-13	175,7	600	151,2	1,18	4,02	1,01	149,1	1,03	3,81	
return gas temp.	-23,3	-10	192,2	656	165,4	1,23	4,21	1,06	155,8	1,05	4,17	
RGT= 32/90	-20	-4	227,8	778	196,0	1,34	4,59	1,16	169,4	1,10	4,95	
liquid temp	-15	5	292,0	997	251,3	1,52	5,20	1,31	191,8	1,18	6,37	
Tliq= 45/113	-10	14	370,6	1266	318,9	1,71	5,86	1,48	216,1	1,28	8,11	
[°C / °F]	-35	-31	81,9	280	70,5	0,70	2,41	0,61	116,2	0,92	1,95	
cond. pressure	-30	-22	112,3	384	96,7	0,84	2,87	0,72	133,8	0,98	2,68	
pc= 55/131	-25	-13	149,0	509	128,3	0,97	3,30	0,83	154,1	1,04	3,56	
return gas temp	-23,3	-10	163,3	558	140,5	1,01	3,45	0,87	161,7	1,07	3,91	
RGT= 32/90	-20	-4	194,0	663	167,0	1,09	3,74	0,94	177,3	1,13	4,65	
liquid temp	-15	5	249,5	852	214,7	1,23	4,19	1,06	203,2	1,22	6,01	
Tliq= 55/131	-10	14	317,4	1084	273,2	1,37	4,68	1,18	231,8	1,34	7,68	

Model

Designation	NL8F	220-240V/50Hz	Conf. 2	Sales code:	105G6822
-------------	-------------	----------------------	----------------	-------------	-----------------

Configuration

Motorconfiguration	RSIR
Power supply (nominal)	220-240V/50Hz 1~
Refrigerant	R134a
Application	LBP
Voltage range	198-254V
Starting torque	LST
Approvals	VDE EAC

Electrical accessories / wiring diagram

RSIR

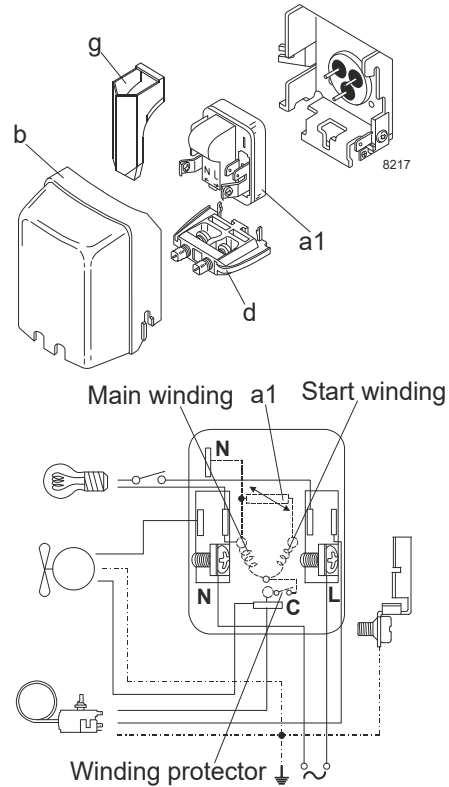

Ambient temperatures / system cooling

Ambient temperature min.:	10°C / 50°F
Ambient temperature max.:	38°C / 101°F

System cooling (n/a: outside limits)			
T ambient	LBP	MBP	HBP
32°C / 90°F	static	n/a	n/a
38°C / 100°F	static	n/a	n/a
43°C / 110°F	n/a	n/a	n/a

Operation pressure range



Components

a1	PTC starter (220V, 250hm, 4.8mm)	103N0018
b	plastic cover	103N2010
d	cord relief	103N1010
g	protection screen for PTC	103N0476

Alternative components

a1	PTC starter (220V, 250hm, 6.3mm)	103N0011
b	plastic cover	103N2011
d	cord relief	103N1010
g	protection screen for PTC	103N0476

Model

Designation	NL8F	220-240V/50Hz	Conf. 2	Sales code:	105G6822
-------------	-------------	----------------------	----------------	-------------	-----------------

Optimization + standard conditions

R134a, 220V/50Hz, RSIR, static, VDE, EAC

		Evaporating pressure (saturation temperature)			Condensing pressure (saturation temperature)			Return gas temp.		Liquid temp.		Cooling capacity			COP	EER	Power consumption			Ref. mass flow m	
		pe	pc	RGT	Tliq	[W]	[Btu/h]	[kcal/h]	[W/W]	[Btu/Wh]	[kcal/Wh]	P1	I	Current consumption							
[°C]	[°F]											[W]	[A]	[kg/h]							
		-23	54,4	32,2	32,2	200,2	684	172,3	1,24	4,25	1,07	161,0	1,06	3,89						ASHRAE LBP	
		-10	130	90	90																
[°C]	[°F]	-25	55	32	55	149,0	509	128,3	0,97	3,30	0,83	154,1	1,04	3,56						cecomaf LBP	
		-13	131	89,6	131																
[°C]	[°F]	-35	40	20	40	109,0	372	93,8	0,95	3,23	0,81	115,1	0,93	2,39						EN12900 LBP	
		-31	104	68	104																
[°C]	[°F]	-23	48,9	4,44	48,9	161,8	553	139,3	1,03	3,52	0,89	157,2	1,04	4,27						ARI540 LBP	
		-10	120	40	120																
[°C]	[°F]	-23	40,6	32,2	32,2	223,8	764	192,6	1,45	4,96	1,25	154,1	1,06	4,35						AHAM LBP	
		-10	105	90	90																
[°C]	[°F]	-35	45	32	45	99,8	341	85,9	0,87	2,96	0,75	115,0	0,92	2,15						opt	
		-31	113	89,6	113																

Performance tables

R134a, 220V/50Hz, RSIR, static, VDE, EAC

	pe	Cooling capacity			COP	EER	P1	I	m		
		[°C]	[°F]	[W]						[Btu/h]	[kcal/h]
[°C / °F]	-35	-31	99,8	341	85,9	0,87	2,96	0,75	115,0	0,92	2,15
cond. pressure	-30	-22	133,7	457	115,1	1,02	3,49	0,88	131,0	0,97	2,89
pc= 45/113	-25	-13	175,7	600	151,2	1,18	4,02	1,01	149,1	1,03	3,81
return gas temp.	-23	-10	192,2	656	165,4	1,23	4,21	1,06	155,8	1,05	4,17
RGT= 32/90	-20	-4	227,8	778	196,0	1,34	4,59	1,16	169,4	1,10	4,95
liquid temp	-15	5	292,0	997	251,3	1,52	5,20	1,31	191,8	1,18	6,37
Tliq= 45/113	-10	14	370,6	1266	318,9	1,71	5,86	1,48	216,1	1,28	8,11
[°C / °F]	-35	-31	81,9	280	70,5	0,70	2,41	0,61	116,2	0,92	1,95
cond. pressure	-30	-22	112,3	384	96,7	0,84	2,87	0,72	133,8	0,98	2,68
pc= 55/131	-25	-13	149,0	509	128,3	0,97	3,30	0,83	154,1	1,04	3,56
return gas temp	-23	-10	163,3	558	140,5	1,01	3,45	0,87	161,7	1,07	3,91
RGT= 32/90	-20	-4	194,0	663	167,0	1,09	3,74	0,94	177,3	1,13	4,65
liquid temp	-15	5	249,5	852	214,7	1,23	4,19	1,06	203,2	1,22	6,01
Tliq= 55/131	-10	14	317,4	1084	273,2	1,37	4,68	1,18	231,8	1,34	7,68



8238-20

NL Compressors

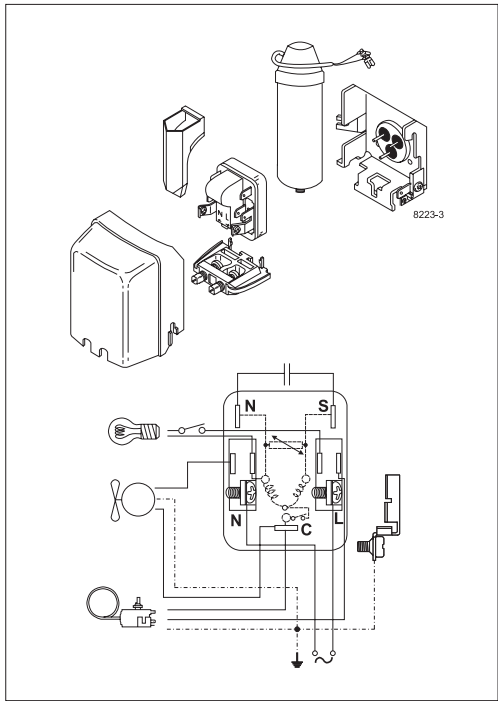
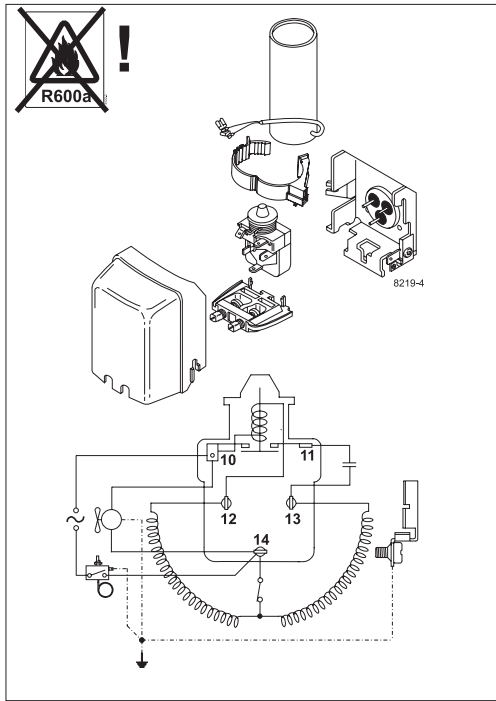
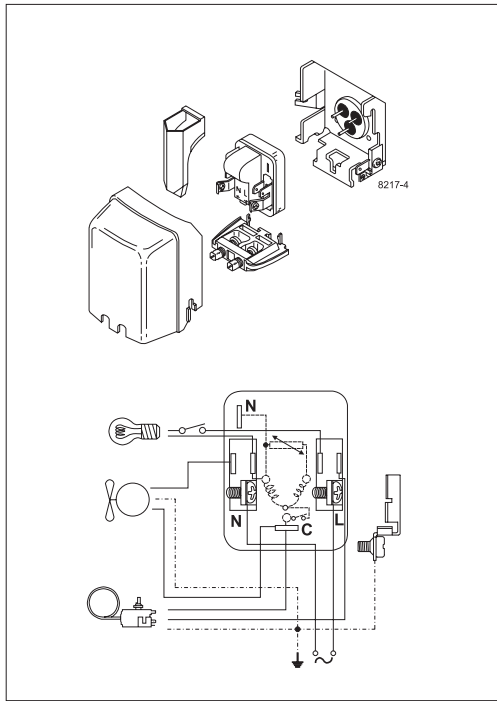



Service/Repair – R600a, R290



8545

Brazing on Suction Connectors (Direct Intake)

representative image



! max. 150°C/302°F !
at socket
 brazing solder: phosphor (LP7) or silver

Refer to Product Bulletin:
Brazing on Suction Connectors
(Compressors with Direct Suction Intake)

Secop accepts no responsibility for possible errors in catalogs, brochures, and other printed material. Secop reserves the right to alter its products without notice. This also applies to products already on order provided that such alterations can be made without subsequential changes being necessary to specifications already agreed. All trademarks in this material are the property of the respective companies. Secop and the Secop logotype are trademarks of Secop GmbH. All rights reserved. www.secop.com