

Single Pack SC12G 208-230V 60Hz CSIR

Single pack code number: **195B4489**

Position	Title	Code	Amount
1	Compressor SC12G	104G8245	1
2	Starting relay	117U6011	1
3	Starting capacitor (80 μ F 220V, 6.3mm)	117U5017	1
4	Cord relief	103N1004	1
5	Cover	103N2008	1
6	Bolt joint for one compressor M6 \varnothing 16mm	118-1917	1

Secop GmbH • Lise-Meitner-Straße 29 • 24941 Flensburg, Germany • Tel: +49 461 4941 0 • www.secop.com

Secop accepts no responsibility for possible errors in catalogs, brochures, and other printed material. Secop reserves the right to alter its products without notice. This also applies to products already on order provided that such alterations can be made without subsequent changes being necessary to specifications already agreed. All trademarks in this material are the property of the respective companies. Secop and the Secop logotype are trademarks of Secop GmbH. All rights reserved.

Model

Designation	SC12G	208-230V/60Hz 1~	Sales code:	104G8245
-------------	--------------	------------------	-------------	-----------------

Compressor design

Oil type	Polyolester	Refrigerant(s)	R134a
Oil viscosity	22cST	Displacement	12,87cm ³ / 0,79cu.in
Oil quantity	500cm ³ / 16,9fl.oz	Compressors on pallet	80
Refr. charge - tech. limit	1300g / 45,9oz		
Free gas volume comp.	1410cm ³ / 47,7fl.oz		
Weight	13kg / 28,7lbs		
Motor protection	1# internal		
Winding resistance main	4,4Ω (at 25°C)		
Winding resistance aux	14Ω (at 25°C)		
Max. winding temp.	125°C / 257°F		
Max. discharge temp.	135°C / 275°F		



General - Configurations with SC12G

	Conf. 1
Motorconfiguration	CSIR
Power supply (nominal)	208-230V/60Hz
Number of phases	1
Voltage range	187-254V
Approvals	VDE, UL, KC
Starting torque	HST
Note	- / -

Applications with SC12G

	Conf. 1
Refrigerant	R134a
Application	MBP
System cooling	fan 3m/s
Hot gas defrost	OK
Long interval pull down	OK

Electrical data - Configurations with SC12G

	Conf. 1
Starting device type	relay
Run capacitor	- / -
Start capacitor	80μF
LRA (locked rotor amps / 4s)	23,4A
RLA (rated load amps / 1s)	4,3A
Cut in current	23,4A

Model

Designation

SC12G

208-230V/60Hz 1~

Sales code:

104G8245

Compressor dimensions

Housing	A Height	209mm / 8,23in
	B Height	203mm / 7,99in
	C Length shell	218mm / 8,58in
	D Length w. cover	255mm / 10,04in
	E Width	151mm / 5,94in

Connectors	Suction X	Discharge Y	Process Z
Diameter [mm]	øi 10,11-10,29	øi 6,41-6,59	øi 6,41-6,59
(i:inside, o:outside) [in]	øi 0,4-0,41	øi 0,25-0,26	øi 0,25-0,26
Material	copper	copper	copper
Horizontal angle ±2°	37°	37°	143°
Vertical angle ±2°	30°	0°	150°
Position l/h/w [mm]	107/183/55	115/100/63	-107/183/55
[in]	4,2/7,2/2,2	4,5/3,9/2,5	-4,2/7,2/2,2
Straight tube l. [mm]	12	12	12
[in]	0,5	0,5	0,5



Compressor fixation



Bolt joint



Snap-on



Mounting accessories

Mounting accessories	one comp.	multi pack
Bolt joint M6 ø16mm	118-1917	118-1918
Bolt joint ø1/4" ø16mm	118-1946	
Bolt joint ø1/4" ø19mm	118-1949	
Snap-on ø7,3 ø16mm	118-1947	118-1919

Application notes

Provision for PE Grounding is located at the PE Stamp on the compressor

LRA value on compressor label and datasheet may differ due to different test conditions for UL approval.

Model

Designation	SC12G	208-230V/60Hz	Conf. 1	Sales code:	104G8245
-------------	--------------	----------------------	----------------	-------------	-----------------

Configuration

Motorconfiguration	CSIR
Power supply (nominal)	208-230V/60Hz 1~
Refrigerant	R134a
Application	MBP
Voltage range	187-254V
Starting torque	HST
Approvals	VDE UL KC

Electrical accessories / wiring diagram

CSIR

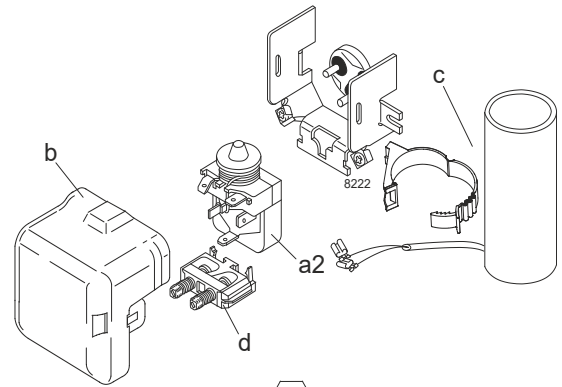

Ambient/ machine room temperatures minimum /maximum

Ambient temperature range:	10 - 43°C / 50 - 110°F
Machine room temperature range:	10 - 48°C / 50 - 119°F
Compressor cooling:	fan 3m/s

Operation Limits

Operation pressure range

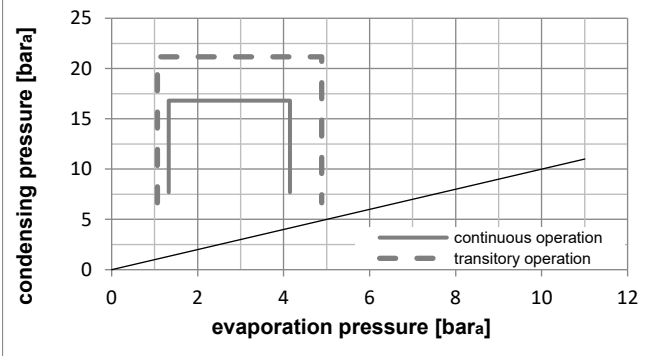
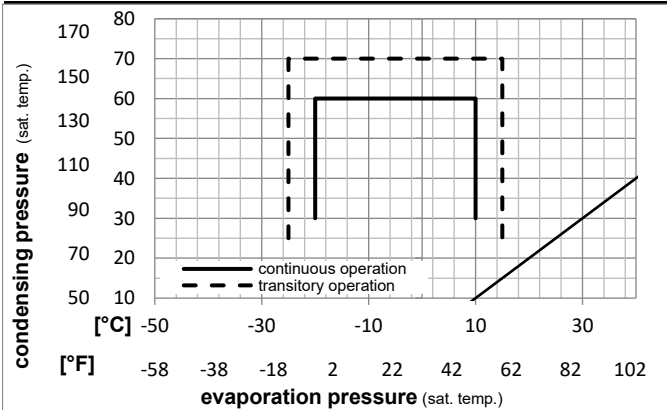

Components

a2	relay	117U6011
c	start capacitor (80μF)	117U5017
d	cord relief	103N1004
b	plastic cover	103N2008

Model

Designation **SC12G** **208-230V/60Hz** Conf. 1 Sales code: **104G8245**

Optimization + standard conditions

R134a, 230V/60Hz, CSIR, fan 3m/s, VDE, UL, KC

	Evaporating pressure (saturation temperature)				Cooling capacity			COP	EER			Power consumption			ASHRAE MBP
	pe	pc	RGT	Tliq	[W]	[Btu/h]	[kcal/h]		[W/W]	[Btu/Wh]	[kcal/Wh]	P1	I	Ref. mass flow	
[°C]	-7	54	35	46	703,4	2402	605,3	1,65	5,65	1,42	425,3	2,73	15,35		
[°F]	20	130	95	115											
[°C]	-10	55	32	55	518,5	1771	446,2	1,34	4,57	1,15	387,6	2,62	12,54	cecomaf MBP	
[°F]	14	131	90	131											
[°C]	-10	45	20	45	622,2	2125	535,4	1,65	5,63	1,42	377,2	2,51	14,56	EN12900 MBP	
[°F]	14	113	68	113											
[°C]	-7	49	18	49	686,9	2346	591,1	1,66	5,67	1,43	413,9	2,66	16,97	ARI540 MBP	
[°F]	20	120	65	120											
[°C]	-10	45	32	45	645,5	2204	555,5	1,71	5,84	1,47	377,2	2,51	14,13	opt	
[°F]	14	113	90	113											
[°C]	-25	45	32	45	213,9	730	184,1	0,90	3,08	0,78	237,0	2,15	4,63	opt	
[°F]	-13	113	90	113											

Performance tables

R134a, 230V/60Hz, CSIR, fan 3m/s, VDE, UL, KC

	pe		Cooling capacity			COP	EER		P1	I	m
	[°C]	[°F]	[W]	[Btu/h]	[kcal/h]		[Btu/Wh]	[kcal/Wh]			
[°C / °F]	-20	-4	332,2	1135	285,9	1,17	3,99	1,01	284,1	2,25	7,22
cond. pressure	-15	5	474,6	1621	408,5	1,43	4,90	1,23	331,1	2,38	10,35
pc= 45/113	-10	14	645,5	2204	555,5	1,71	5,84	1,47	377,2	2,51	14,13
return gas temp.	-7	20	775,9	2650	667,7	1,91	6,51	1,64	407,0	2,61	17,03
RGT= 32/90	0	32	1089,7	3721	937,8	2,34	8,01	2,02	464,7	2,84	24,10
liquid temp	5	41	1371,6	4684	1180,4	2,72	9,28	2,34	504,9	3,02	30,54
Tliq= 45/113	10	50	1699,2	5803	1462,3	3,14	10,71	2,70	541,7	3,22	38,13
[°C / °F]	-20	-4	247,7	846	213,2	0,91	3,12	0,79	271,4	2,28	5,94
cond. pressure	-15	5	370,5	1265	318,9	1,13	3,84	0,97	329,2	2,44	8,92
pc= 55/131	-10	14	518,5	1771	446,2	1,34	4,57	1,15	387,6	2,62	12,54
return gas temp	-7	20	632,1	2159	544,0	1,48	5,07	1,28	426,1	2,74	15,34
RGT= 32/90	0	32	907,5	3099	781,0	1,80	6,16	1,55	503,3	3,01	22,20
liquid temp	5	41	1157,1	3952	995,8	2,07	7,06	1,78	559,4	3,23	28,51
Tliq= 55/131	10	50	1449,2	4949	1247,2	2,36	8,07	2,03	613,6	3,46	36,02



SC Compressors





SC Compressors

Service/Repair – R290



8545



Secop accepts no responsibility for possible errors in catalogs, brochures, and other printed material. Secop reserves the right to alter its products without notice. This also applies to products already on order provided that such alterations can be made without subsequent changes being necessary to specifications already agreed. All trademarks in this material are the property of the respective companies. Secop and the Secop logotype are trademarks of Secop GmbH. All rights reserved. www.secop.com