

Single Pack KLF7.7MFT 200-240V 50Hz / 208-230V 60Hz CSIR

Single pack code number: **195B4689**

Position	Title	Code	Amount
1	Compressor KLF7.7MFT	106G2802	1
2	KL accessories	103N1060	1
3	Starting capacitor (80 μ F 220V, 6.3mm)	117U5001	1
4	Starting relay (QLZ-5.5A, overload protector T0377/L6)	117U7071	1
5	Bolt joint for one compressor M6 \varnothing 16mm	118-1917	1

Secop GmbH • Lise-Meitner-Straße 29 • 24941 Flensburg, Germany • Tel: +49 461 4941 0 • www.secop.com

Secop accepts no responsibility for possible errors in catalogs, brochures, and other printed material. Secop reserves the right to alter its products without notice. This also applies to products already on order provided that such alterations can be made without subsequent changes being necessary to specifications already agreed. All trademarks in this material are the property of the respective companies. Secop and the Secop logotype are trademarks of Secop GmbH. All rights reserved.

Model

Designation	KLF7.7MFT	200-240V/50Hz 1~	208-230V/60Hz 1~	Sales code:	106G2802
-------------	------------------	------------------	------------------	-------------	-----------------

Compressor design

Oil type	Polyolester	Refrigerant(s)	R134a
Oil viscosity	10,4cSt	Displacement	7,7cm ³ / 0,47cu.in
Oil quantity	174cm ³ / 5,9fl.oz	Compressors on pallet	100
Refr. charge - tech. limit	400g / 14,1oz		
Free gas volume comp.	1575cm ³ / 53,3fl.oz		
Weight	9,4kg / 20,7lbs		
Motor protection	external		
Winding resistance main	8,4Ω (at 25°C)		
Winding resistance aux	11,9Ω (at 25°C)		
Max. winding temp.	125°C / 257°F		
Max. discharge temp.	130°C / 266°F		



General - Configurations with KLF7.7MFT

	Conf. 1	Conf. 2	Conf. 3	Conf. 4
Motorconfiguration	CSIR	RSCR	CSIR	RSCR
Power supply (nominal)	200-240V/50Hz	200-240V/50Hz	208-230V/60Hz	208-230V/60Hz
Number of phases	1	1	1	1
Voltage range	170-254V	170-254V	198-253V	198-253V
Approvals	VDE, UL, CCC	VDE, UL, CCC	VDE, UL, CCC	VDE, UL, CCC
Starting torque	HST	LST	HST	LST
Note	Compressor can operate safely in LBP, no official third-party approval yet			

Applications with KLF7.7MFT

	Conf. 1	Conf. 2	Conf. 3	Conf. 4
Refrigerant	R134a	R134a	R134a	R134a
Application	MBP	MBP	MBP	MBP
System cooling	fan 3m/s	fan 3m/s	fan 3m/s	fan 3m/s
Hot gas defrost	OK	OK	OK	OK
Long interval pull down	OK	OK	OK	OK

Electrical data - Configurations with KLF7.7MFT

	Conf. 1	Conf. 2	Conf. 3	Conf. 4
Starting device type	relay	PTC	relay	PTC
Run capacitor	-/-	5μF	-/-	5μF
Start capacitor	80μF	-/-	80μF	-/-
LRA (locked rotor amps / 4s/ U(N))	13,5A	13,5A	13,5A	13,5A
RLA (rated load amps / 1s/ U(N))	2,1A	2,1A	2,1A	2,1A
Cut in current (U(N))	12,3A	18,1A	12,3A	18,1A

Model

Designation	KLF7.7MFT	200-240V/50Hz 1~ 208-230V/60Hz 1~	Sales code:	106G2802
-------------	------------------	-----------------------------------	-------------	-----------------

Compressor dimensions

Housing	A Height	182mm / 7,17in
	B Height	175mm / 6,89in
	C Length shell	198mm / 7,8in
	D Length w. cover	238mm / 9,37in
	E Width	160mm / 6,3in

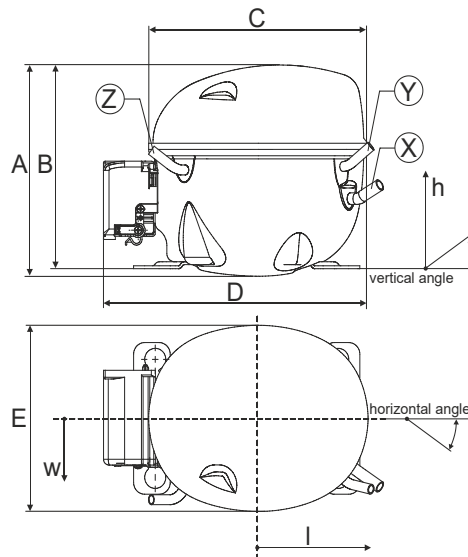

Connectors		Suction	Discharge	Process
		X	Y	Z
Diameter	[mm]	øi 8,11-8,29	øi 6,11-6,29	øi 6,11-6,29
(i:inside, o:outside)	[in]	øi 0,32-0,33	øi 0,24-0,25	øi 0,24-0,25
Material		copper	copper	copper
Horizontal angle	±2°	35°	13°	0°
Vertical angle	±2°	30°	40°	145°
Position l/h/w	[mm]	119/73/59	117/107/66	-88/101/71
	[in]	4,7/2,9/2,3	4,6/4,2/2,6	-3,5/4/2,8
Straight tube l.	[mm]	14	14	14
	[in]	0,5	0,5	0,5

Compressor fixation



Bolt joint

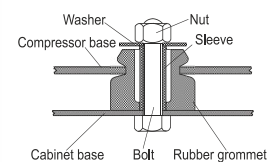

Snap-on



Mounting accessories	one comp.	multi pack
Bolt joint M6 ø16mm	118-1917	118-1918
Bolt joint ø1/4" ø16mm	118-1946	
Bolt joint ø1/4" ø19mm	118-1949	
Snap-on ø7,3 ø16mm	118-1947	118-1919

Application notes

Provision for PE Grounding is located at the PE Stamp on the compressor

Model

Designation	KLF7.7MFT	200-240V/50Hz	Conf. 1	Sales code:	106G2802
-------------	------------------	----------------------	----------------	-------------	-----------------

Configuration

Motorconfiguration	CSIR
Power supply (nominal)	200-240V/50Hz 1~
Refrigerant	R134a
Application	MBP
Voltage range	170-254V
Starting torque	HST
Approvals	VDE
	UL
	CCC

Electrical accessories / wiring diagram

CSIR



Ambient/ machine room temperatures minimum /maximum

Ambient temperature range:	10 - 43°C / 50 - 110°F
Machine room temperature range:	10 - 48°C / 50 - 119°F
Compressor cooling:	fan 3m/s



Operation pressure range

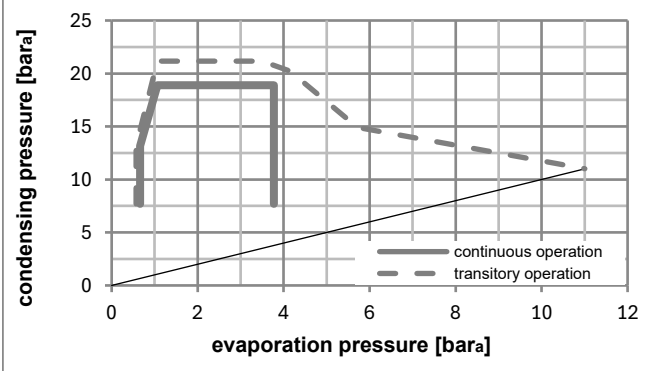
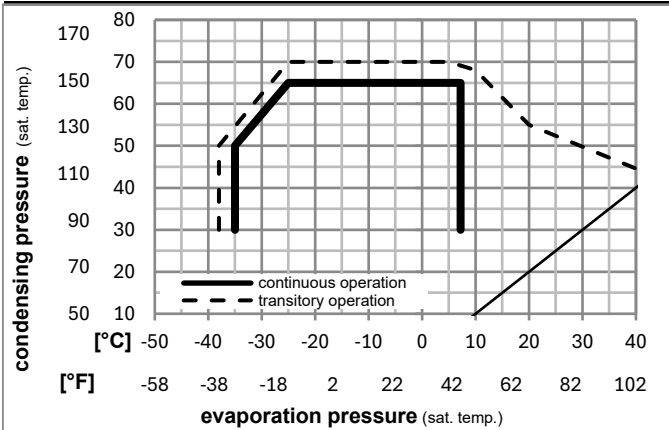

Components

a5	current relay (T0377/L6-S1)	117U7071
c	start capacitor (80µF, 6.3mm)	117U5001
b, d	cover + clamp + screws(5VA) in bag	103N1060

Alternative components

b, d	100x cover + clamp + screws(5VA)	103N2060
b, d	cover + clamp + screws(5VA-compl.)	103N0600

Model

Designation **KLF7.7MFT** **200-240V/50Hz** Conf. 1 Sales code: **106G2802**

Optimization + standard conditions

R134a, 200V/50Hz, CSIR, fan 3m/s, VDE, UL, CCC

	Evaporating pressure (saturation temperature)				Condensing pressure (saturation temperature)			Return gas temp.	Liquid temp.	Cooling capacity	COP	EER	Power consumption			Ref. mass flow
	pe	pc	RGT	Tliq	[W]	[Btu/h]	[kcal/h]						P1	I	m	
	[°C]	[°F]	[°C]	[°F]	[W]	[Btu/h]	[kcal/h]	[W/W]	[Btu/Wh]	[kcal/Wh]	[W]	[A]	[kg/h]			
ASHRAE LBP	-23	54	32	32	220,7	754	190,0	1,37	4,70	1,18	160,6	1,33	4,29			
	-10	130	90	90												
cecomaf LBP	-25	55	32	55	161,7	552	139,2	1,05	3,60	0,91	153,4	1,31	3,87			
	-13	131	90	131												
EN12900 LBP	-35	40	20	40	116,2	397	100,0	1,04	3,57	0,90	111,2	1,20	2,55			
	-31	104	68	104												
ASHRAE MBP	-7	54	35	46	462,0	1578	397,6	1,89	6,46	1,63	244,1	1,63	10,08			
	20	130	95	115												
cecomaf MBP	-10	55	32	55	358,4	1224	308,4	1,58	5,39	1,36	227,2	1,56	8,67			
	14	131	90	131												
EN12900 MBP	-10	45	20	45	402,0	1373	346,0	1,90	6,50	1,64	211,4	1,50	9,41			
	14	113	68	113												

Performance tables

R134a, 200V/50Hz, CSIR, fan 3m/s, VDE, UL, CCC

	pe		Cooling capacity			COP	EER	P1	I	m	
	[°C]	[°F]	[W]	[Btu/h]	[kcal/h]	[W/W]	[Btu/Wh]	[kcal/Wh]	[W]	[A]	[kg/h]
[°C / °F]	-30	-22	145,0	495	124,8	1,12	3,82	0,96	129,5	1,24	3,13
cond. pressure	-25	-13	192,7	658	165,9	1,29	4,42	1,11	149,0	1,29	4,18
pc= 45/113	-15	5	328,1	1120	282,3	1,73	5,89	1,49	190,1	1,42	7,15
return gas temp.	-10	14	417,1	1424	358,9	1,97	6,74	1,70	211,4	1,50	9,13
RGT= 32/90	-5	23	521,3	1780	448,6	2,24	7,65	1,93	232,9	1,58	11,46
liquid temp	0	32	641,5	2191	552,0	2,52	8,61	2,17	254,4	1,67	14,19
Tliq= 45/113	7,2	45	843,9	2882	726,3	2,96	10,11	2,55	285,1	1,80	18,85
[°C / °F]	-30	-22	118,7	406	102,2	0,90	3,08	0,78	131,8	1,25	2,83
cond. pressure	-25	-13	161,7	552	139,2	1,05	3,60	0,91	153,4	1,31	3,87
pc= 55/131	-15	5	280,8	959	241,6	1,39	4,76	1,20	201,3	1,46	6,76
return gas temp	-10	14	358,4	1224	308,4	1,58	5,39	1,36	227,2	1,56	8,67
RGT= 32/90	-5	23	448,9	1533	386,4	1,77	6,03	1,52	254,2	1,67	10,91
liquid temp	0	32	553,2	1889	476,1	1,96	6,70	1,69	282,0	1,78	13,53
Tliq= 55/131	7,2	45	728,9	2489	627,3	2,25	7,70	1,94	323,3	1,96	18,03

Model

Designation	KLF7.7MFT	200-240V/50Hz	Conf. 2	Sales code:	106G2802
-------------	------------------	----------------------	----------------	-------------	-----------------

Configuration

Motorconfiguration	RSCR
Power supply (nominal)	200-240V/50Hz 1~
Refrigerant	R134a
Application	MBP
Voltage range	170-254V
Starting torque	LST
Approvals	VDE
	UL
	CCC

Electrical accessories / wiring diagram

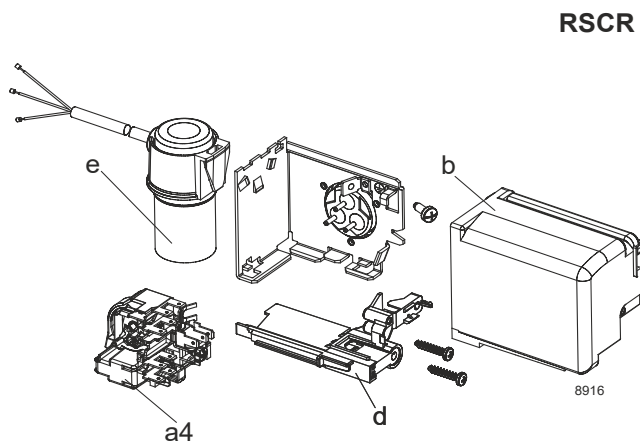

Ambient/ machine room temperatures minimum /maximum

Ambient temperature range: 10 - 43°C / 50 - 110°F

Machine room temperature range: 10 - 48°C / 50 - 119°F

Compressor cooling: fan 3m/s

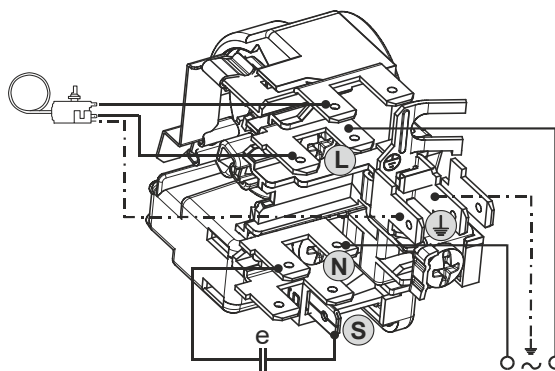

Operation pressure range

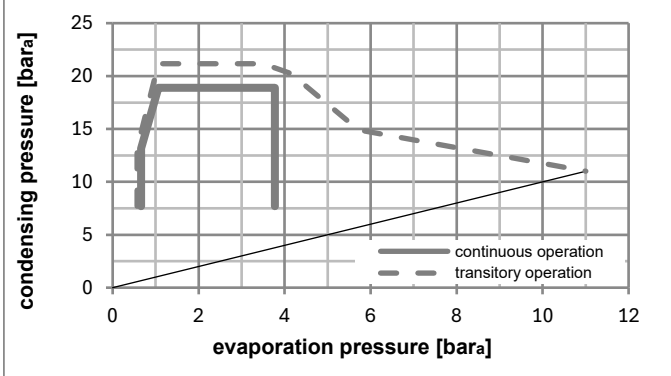
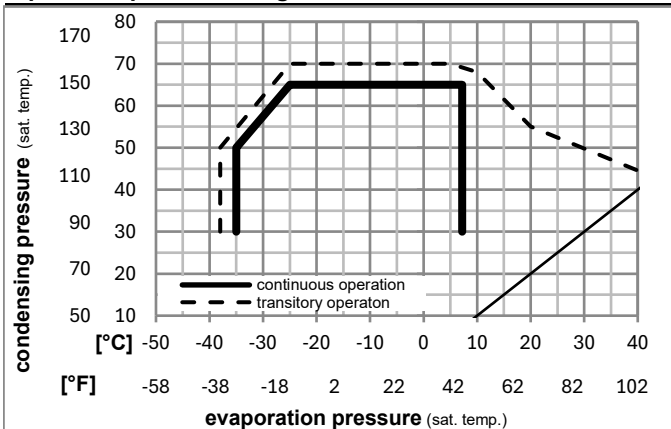

Components

a4	DAS1 (PTC,6.3mm, T0377/L6 - S1)	103N0250
e	run capacitor (5µF, 6.3mm)	117-7191
b, d	cover + clamp + screws(5VA) in bag	103N1060

Alternative components

a4	ZAS1 (PTC,4.8mm, T0377/L6 - S1)	103N0252
e	run capacitor (5µF, 4.8mm)	117-7190

b, d	100x cover + clamp + screws(5VA)	103N2060
b, d	cover + clamp + screws(5VA-compl.)	103N0600

Model

Designation **KLF7.7MFT** **200-240V/50Hz** Conf. 2 Sales code: **106G2802**

Optimization + standard conditions

R134a, 200V/50Hz, RSCR, fan 3m/s, VDE, UL, CCC

	Evaporating pressure (saturation temperature)				Cooling capacity			COP	EER	P1	Power consumption		ASHRAE LBP	
	pe	pc	RGT	Tliq	[W]	[Btu/h]	[kcal/h]				I	m		
	[°C]	[°F]	[°C]	[°F]	[W]	[Btu/h]	[kcal/h]	[W/W]	[Btu/Wh]	[kcal/Wh]	[W]	[A]	[kg/h]	
	-23	54	32	32	221,1	755	190,3	1,45	4,94	1,24	152,9	1,00	4,29	ASHRAE LBP
	-10	130	90	90										
	-25	55	32	55	161,9	553	139,4	1,11	3,79	0,95	146,0	0,98	3,87	cecomaf LBP
	-13	131	90	131										
	-35	40	20	40	116,3	397	100,0	1,11	3,78	0,95	105,2	0,84	2,55	EN12900 LBP
	-31	104	68	104										
	-7	54	35	46	463,3	1582	398,7	2,00	6,83	1,72	231,8	1,34	10,11	ASHRAE MBP
	20	130	95	115										
	-10	55	32	55	359,3	1227	309,2	1,66	5,68	1,43	216,0	1,27	8,69	cecomaf MBP
	14	131	90	131										
	-10	45	20	45	403,0	1376	346,8	2,00	6,84	1,72	201,1	1,20	9,43	EN12900 MBP
	14	113	68	113										

Performance tables

R134a, 200V/50Hz, RSCR, fan 3m/s, VDE, UL, CCC

	pe		Cooling capacity			COP	EER	P1	I	m	
	[°C]	[°F]	[W]	[Btu/h]	[kcal/h]						
[°C / °F]	-30	-22	145,1	496	124,9	1,18	4,03	1,02	123,0	0,89	3,14
cond. pressure	-25	-13	193,0	659	166,1	1,36	4,65	1,17	141,8	0,96	4,18
pc= 45/113	-15	5	328,7	1123	282,9	1,82	6,20	1,56	181,0	1,11	7,17
return gas temp.	-10	14	418,1	1428	359,8	2,08	7,10	1,79	201,1	1,20	9,15
RGT= 32/90	-5	23	522,7	1785	449,8	2,36	8,07	2,03	221,3	1,29	11,49
liquid temp	0	32	643,4	2197	553,7	2,66	9,10	2,29	241,5	1,38	14,23
Tliq= 45/113	7,2	45	846,9	2892	728,8	3,14	10,71	2,70	270,1	1,52	18,92
[°C / °F]	-30	-22	118,9	406	102,4	0,95	3,25	0,82	125,1	0,90	2,84
cond. pressure	-25	-13	161,9	553	139,4	1,11	3,79	0,95	146,0	0,98	3,87
pc= 55/131	-15	5	281,4	961	242,1	1,47	5,02	1,26	191,6	1,16	6,77
return gas temp	-10	14	359,3	1227	309,2	1,66	5,68	1,43	216,0	1,27	8,69
RGT= 32/90	-5	23	450,3	1538	387,5	1,87	6,38	1,61	241,2	1,38	10,95
liquid temp	0	32	555,2	1896	477,8	2,08	7,10	1,79	267,1	1,50	13,58
Tliq= 55/131	7,2	45	732,1	2500	630,1	2,40	8,19	2,06	305,4	1,69	18,11

Model

Designation	KLF7.7MFT	208-230V/60Hz	Conf. 3	Sales code:	106G2802
-------------	------------------	----------------------	----------------	-------------	-----------------

Configuration

Motorconfiguration	CSIR
Power supply (nominal)	208-230V/60Hz 1~
Refrigerant	R134a
Application	MBP
Voltage range	198-253V
Starting torque	HST
Approvals	VDE
	UL
	CCC

Electrical accessories / wiring diagram

CSIR

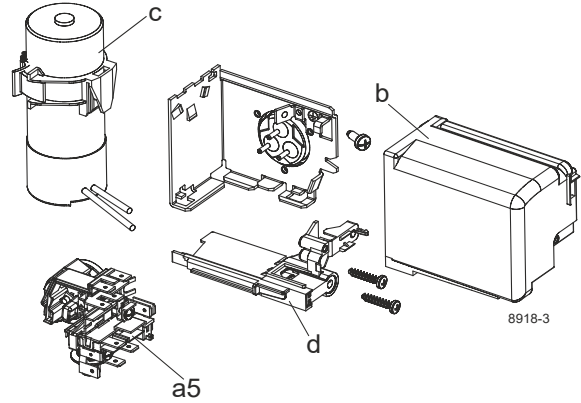

Ambient/ machine room temperatures minimum /maximum

Ambient temperature range:	10 - 43°C / 50 - 110°F
Machine room temperature range:	10 - 48°C / 50 - 119°F
Compressor cooling:	fan 3m/s

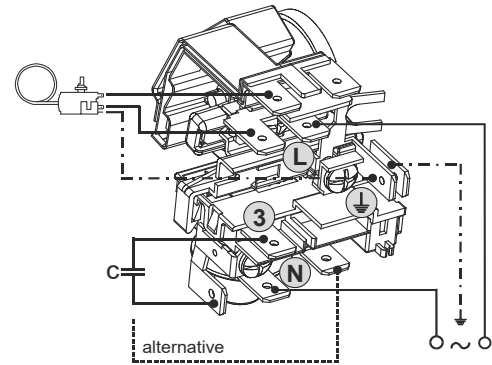

Operation pressure range

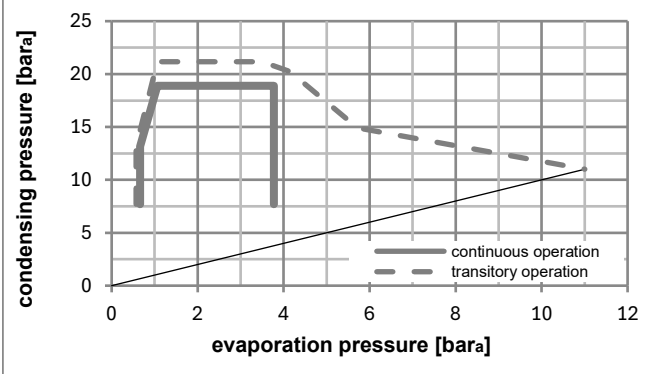
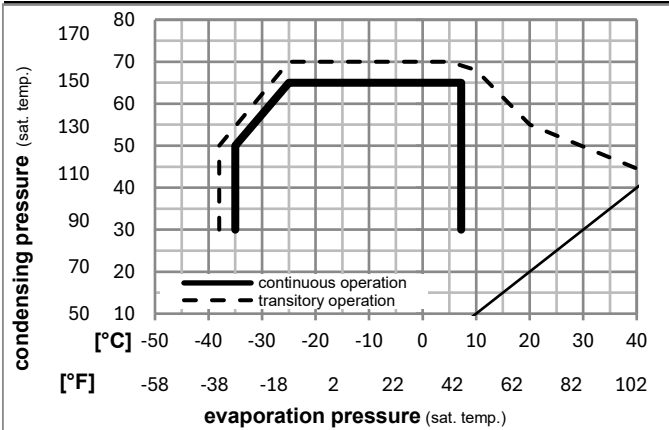

Components

a5	current relay (T0377/L6-S1)	117U7071
c	start capacitor (80µF, 6.3mm)	117U5001
b, d	cover + clamp + screws(5VA) in bag	103N1060

Alternative components

b, d	100x cover + clamp + screws(5VA)	103N2060
b, d	cover + clamp + screws(5VA-compl.)	103N0600

Model

Designation **KLF7.7MFT** **208-230V/60Hz** Conf. **3** Sales code: **106G2802**

Optimization + standard conditions

R134a, 208V/60Hz, CSIR, fan 3m/s, VDE, UL, CCC

	Evaporating pressure (saturation temperature)				Condensing pressure (saturation temperature)			Return gas temp.	Liquid temp.	Cooling capacity	COP	EER	Power consumption			Ref. mass flow
	pe	pc	RGT	Tliq	[W]	[Btu/h]	[kcal/h]						P1	I	m	
	[°C]	[°F]	[°C]	[°F]	[W]	[Btu/h]	[kcal/h]	[W/W]	[Btu/Wh]	[kcal/Wh]	[W]	[A]	[kg/h]			
ASHRAE LBP	-23	54	32	32	259,9	888	223,7	1,37	4,68	1,18	189,6	1,31	5,05			
	-10	130	90	90												
cecomaf LBP	-25	55	32	55	190,4	650	163,9	1,05	3,60	0,91	180,7	1,28	4,55			
	-13	131	90	131												
EN12900 LBP	-35	40	20	40	134,7	460	116,0	1,07	3,65	0,92	126,1	1,15	2,96			
	-31	104	68	104												
ASHRAE MBP	-7	54	35	46	545,0	1861	469,0	1,87	6,40	1,61	290,9	1,65	11,89			
	20	130	95	115												
cecomaf MBP	-10	55	32	55	422,7	1444	363,8	1,56	5,33	1,34	270,6	1,57	10,22			
	14	131	90	131												
EN12900 MBP	-10	45	20	45	473,7	1618	407,7	1,89	6,44	1,62	251,1	1,51	11,09			
	14	113	68	113												

Performance tables

R134a, 208V/60Hz, CSIR, fan 3m/s, VDE, UL, CCC

	pe		Cooling capacity			COP	EER	P1	I	m	
	[°C]	[°F]	[W]	[Btu/h]	[kcal/h]	[W/W]	[Btu/Wh]	[kcal/Wh]	[W]	[A]	[kg/h]
[°C / °F]	-30	-22	169,1	578	145,6	1,13	3,85	0,97	149,9	1,20	3,66
cond. pressure	-25	-13	226,0	772	194,5	1,29	4,42	1,11	174,6	1,27	4,90
pc= 45/113	-15	5	386,2	1319	332,4	1,71	5,85	1,48	225,3	1,42	8,42
return gas temp.	-10	14	491,5	1678	422,9	1,96	6,68	1,68	251,1	1,51	10,76
RGT= 32/90	-5	23	614,6	2099	529,0	2,22	7,57	1,91	277,1	1,60	13,52
liquid temp	0	32	756,7	2584	651,2	2,50	8,52	2,15	303,2	1,69	16,73
Tliq= 45/113	7,2	45	996,2	3402	857,3	2,93	9,99	2,52	340,5	1,83	22,25
[°C / °F]	-30	-22	139,5	476	120,1	0,91	3,10	0,78	153,6	1,21	3,33
cond. pressure	-25	-13	190,4	650	163,9	1,05	3,60	0,91	180,7	1,28	4,55
pc= 55/131	-15	5	331,1	1131	284,9	1,38	4,72	1,19	239,3	1,46	7,97
return gas temp	-10	14	422,7	1444	363,8	1,56	5,33	1,34	270,6	1,57	10,22
RGT= 32/90	-5	23	529,7	1809	455,8	1,75	5,97	1,50	303,1	1,69	12,88
liquid temp	0	32	653,0	2230	562,0	1,94	6,62	1,67	336,7	1,82	15,97
Tliq= 55/131	7,2	45	861,0	2941	741,0	2,23	7,60	1,92	386,7	2,02	21,29

Model

Designation	KLF7.7MFT	208-230V/60Hz	Conf. 4	Sales code:	106G2802
-------------	------------------	----------------------	----------------	-------------	-----------------

Configuration

Motor configuration	RSCR
Power supply (nominal)	208-230V/60Hz 1~
Refrigerant	R134a
Application	MBP
Voltage range	198-253V
Starting torque	LST
Approvals	VDE UL CCC

Electrical accessories / wiring diagram

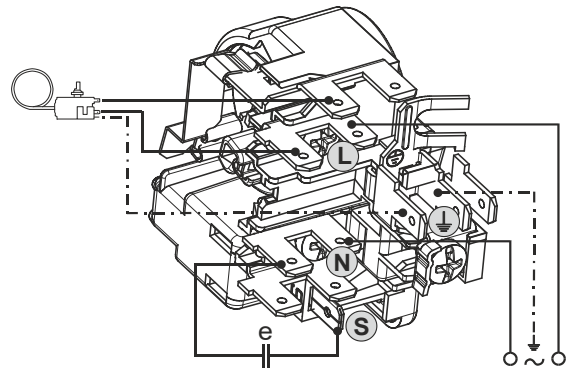

Ambient/ machine room temperatures minimum /maximum

Ambient temperature range:	10 - 43°C / 50 - 110°F
Machine room temperature range:	10 - 48°C / 50 - 119°F
Compressor cooling:	fan 3m/s

Operation pressure range

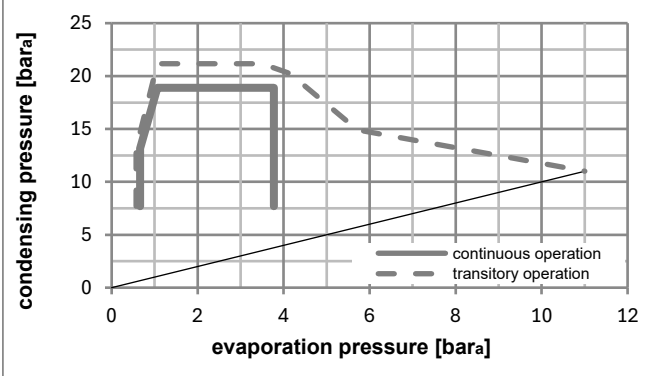
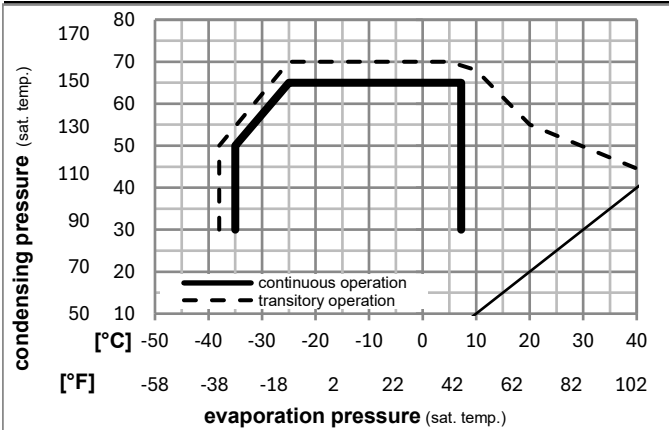

Components

a4	DAS1 (PTC, 6.3mm, T0377/L6 - S1)	103N0250
e	run capacitor (5µF, 6.3mm)	117-7191
b, d	cover + clamp + screws(5VA) in bag	103N1060

Alternative components

a4	ZAS1 (PTC, 4.8mm, T0377/L6 - S1)	103N0252
e	run capacitor (5µF, 4.8mm)	117-7190

b, d	100x cover + clamp + screws(5VA)	103N2060
b, d	cover + clamp + screws(5VA-compl.)	103N0600

Model

Designation **KLF7.7MFT** **208-230V/60Hz** Conf. 4 Sales code: **106G2802**

Optimization + standard conditions

R134a, 208V/60Hz, RSCR, fan 3m/s, VDE, UL, CCC

	Evaporating pressure (saturation temperature)				Condensing pressure (saturation temperature)			Return gas temp.	Liquid temp.	Cooling capacity	COP	EER	Power consumption			Ref. mass flow
	pe	pc	RGT	Tliq	[W]	[Btu/h]	[kcal/h]						P1	I	m	
	[°C]	[°F]	[°C]	[°F]	[W]	[Btu/h]	[kcal/h]	[W/W]	[Btu/Wh]	[kcal/Wh]	[W]	[A]	[kg/h]			
ASHRAE LBP	-23	54	32	32	260,4	889	224,1	1,44	4,92	1,24	180,8	0,90	5,06			
	-10	130	90	90												
cecomaf LBP	-25	55	32	55	190,7	651	164,1	1,11	3,78	0,95	172,4	0,87	4,56			
	-13	131	90	131												
EN12900 LBP	-35	40	20	40	134,8	460	116,0	1,12	3,81	0,96	120,8	0,67	2,96			
	-31	104	68	104												
ASHRAE MBP	-7	54	35	46	546,5	1867	470,4	1,98	6,78	1,71	275,4	1,29	11,92			
	20	130	95	115												
cecomaf MBP	-10	55	32	55	423,7	1447	364,7	1,65	5,64	1,42	256,6	1,21	10,25			
	14	131	90	131												
EN12900 MBP	-10	45	20	45	474,8	1621	408,6	1,99	6,80	1,71	238,6	1,13	11,11			
	14	113	68	113												

Performance tables

R134a, 208V/60Hz, RSCR, fan 3m/s, VDE, UL, CCC

	pe		Cooling capacity			COP	EER	P1	I	m	
	[°C]	[°F]	[W]	[Btu/h]	[kcal/h]	[W/W]	[Btu/Wh]				[kcal/Wh]
[°C / °F]	-30	-22	169,3	578	145,7	1,18	4,03	1,02	143,4	0,76	3,66
cond. pressure	-25	-13	226,3	773	194,7	1,36	4,64	1,17	166,7	0,85	4,90
pc= 45/113	-15	5	387,0	1322	333,0	1,80	6,16	1,55	214,4	1,04	8,44
return gas temp.	-10	14	492,6	1682	423,9	2,06	7,05	1,78	238,6	1,13	10,78
RGT= 32/90	-5	23	616,2	2105	530,3	2,35	8,01	2,02	262,7	1,24	13,55
liquid temp	0	32	758,9	2592	653,1	2,65	9,04	2,28	286,8	1,34	16,78
Tliq= 45/113	7,2	45	999,6	3414	860,2	3,11	10,63	2,68	321,1	1,48	22,33
[°C / °F]	-30	-22	139,7	477	120,2	0,95	3,25	0,82	146,8	0,77	3,33
cond. pressure	-25	-13	190,7	651	164,1	1,11	3,78	0,95	172,4	0,87	4,56
pc= 55/131	-15	5	331,8	1133	285,5	1,46	4,98	1,26	227,4	1,09	7,99
return gas temp	-10	14	423,7	1447	364,7	1,65	5,64	1,42	256,6	1,21	10,25
RGT= 32/90	-5	23	531,3	1814	457,2	1,85	6,33	1,59	286,7	1,34	12,91
liquid temp	0	32	655,2	2238	563,9	2,06	7,05	1,78	317,6	1,47	16,03
Tliq= 55/131	7,2	45	864,6	2953	744,0	2,38	8,12	2,05	363,4	1,67	21,38



KL Compressors

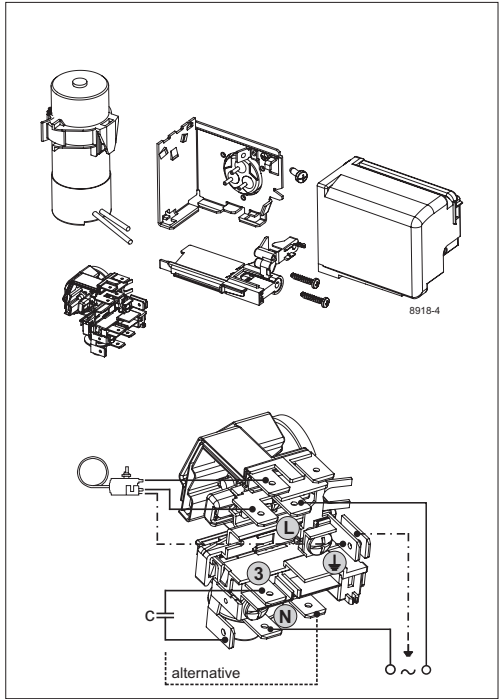

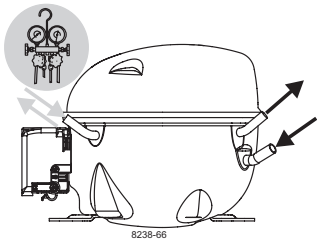

KL Compressors



Service/Repair – R290

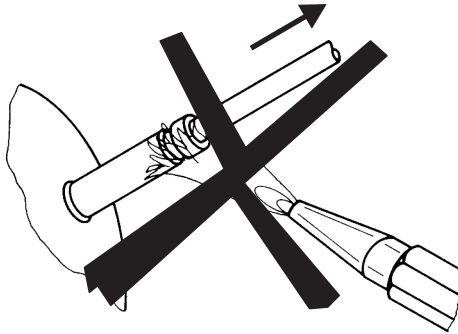

8545

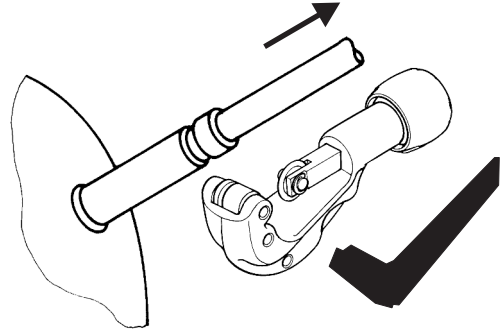

Secop accepts no responsibility for possible errors in catalogs, brochures, and other printed material. Secop reserves the right to alter its products without notice. This also applies to products already on order provided that such alterations can be made without subsequent changes being necessary to specifications already agreed. All trademarks in this material are the property of the respective companies. Secop and the Secop logotype are trademarks of Secop GmbH. All rights reserved. www.secop.com