

Single Pack KLF4.8CNT 200-240V 50Hz / 208-230V 60Hz CSIR

Single pack code number: **195B4698**

| Position | Title | Code | Amount |
|----------|--|----------|--------|
| 1 | Compressor KLF4.8CNT | 106H2512 | 1 |
| 2 | Bolt joint for one compressor M6 ø16mm | 118-1917 | 1 |

Secop GmbH • Lise-Meitner-Straße 29 • 24941 Flensburg, Germany • Tel: +49 461 4941 0 • www.secop.com

Secop accepts no responsibility for possible errors in catalogs, brochures, and other printed material. Secop reserves the right to alter its products without notice. This also applies to products already on order provided that such alterations can be made without subsequent changes being necessary to specifications already agreed. All trademarks in this material are the property of the respective companies. Secop and the Secop logotype are trademarks of Secop GmbH. All rights reserved.

Model

| | | | | |
|-------------|------------------|-----------------------------------|-------------|-----------------|
| Designation | KLF4.8CNT | 200-240V/50Hz 1~ 208-230V/60Hz 1~ | Sales code: | 106H2512 |
|-------------|------------------|-----------------------------------|-------------|-----------------|

Compressor design

| | | | |
|----------------------------|---------------------------------|-----------------------|--------------------------------|
| Oil type | Polyolester | Refrigerant(s) | R290 |
| Oil viscosity | 19,2cSt | Displacement | 4,8cm ³ / 0,29cu.in |
| Oil quantity | 162cm ³ / 5,5fl.oz | Compressors on pallet | 100 |
| Refr. charge - tech. limit | 200g / 7,1oz | | |
| Free gas volume comp. | 1615cm ³ / 54,6fl.oz | | |
| Weight | 9,2kg / 20,3lbs | | |
| Motor protection | external | | |
| Winding resistance main | 10,7Ω (at 25°C) | | |
| Winding resistance aux | 17Ω (at 25°C) | | |
| Max. winding temp. | 125°C / 257°F | | |
| Max. discharge temp. | 130°C / 266°F | | |



General - Configurations with KLF4.8CNT

| | Conf. 1 | Conf. 2 |
|------------------------|---|-----------------|
| Motorconfiguration | CSIR | CSIR |
| Power supply (nominal) | 200-240V/50Hz | 208-230V/60Hz |
| Number of phases | 1 | 1 |
| Voltage range | 187-254V | 198-253V |
| Approvals | UL, CCC, CB | UL, CCC, CB, KC |
| Starting torque | HST | HST |
| Note | Electrical equipment is included and pre-assembled to compressor. | |

Applications with KLF4.8CNT

| | Conf. 1 | Conf. 2 |
|-------------------------|----------------|----------------|
| Refrigerant | R290 | R290 |
| Application | LBP+MBP | LBP+MBP |
| System cooling | fan 3m/s | fan 3m/s |
| Hot gas defrost | OK | OK |
| Long interval pull down | OK | -/- |

Electrical data - Configurations with KLF4.8CNT

| | Conf. 1 | Conf. 2 |
|------------------------------------|----------------|----------------|
| Starting device type | relay | relay |
| Run capacitor | -/- | -/- |
| Start capacitor | 80μF | 80μF |
| LRA (locked rotor amps / 4s/ U(N)) | 11,3A | 11,3A |
| RLA (rated load amps / 1s/ U(N)) | 1,7A | 1,7A |
| Cut in current (U(N)) | 10,7A | 10,7A |

Model

| | | | | |
|-------------|------------------|-----------------------------------|-------------|-----------------|
| Designation | KLF4.8CNT | 200-240V/50Hz 1~ 208-230V/60Hz 1~ | Sales code: | 106H2512 |
|-------------|------------------|-----------------------------------|-------------|-----------------|

Compressor dimensions

| | | |
|----------------|-------------------|----------------|
| Housing | A Height | 182mm / 7,17in |
| | B Height | 175mm / 6,89in |
| | C Length shell | 198mm / 7,8in |
| | D Length w. cover | 238mm / 9,37in |
| | E Width | 160mm / 6,3in |

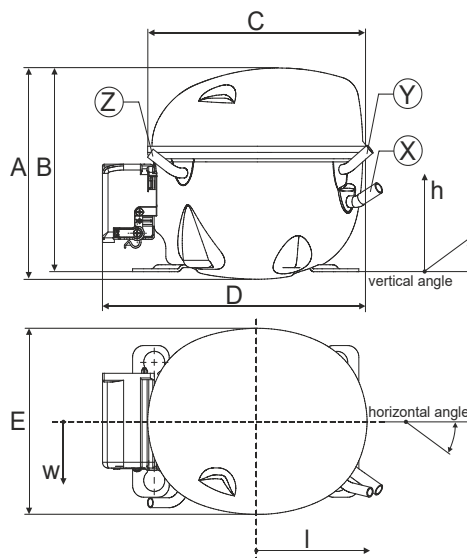

| Connectors | | Suction | Discharge | Process |
|-----------------------|------|--------------|--------------|--------------|
| | | X | Y | Z |
| Diameter | [mm] | øi 8,11-8,29 | øi 6,11-6,29 | øi 6,11-6,29 |
| (i:inside, o:outside) | [in] | øi 0,32-0,33 | øi 0,24-0,25 | øi 0,24-0,25 |
| Material | | copper | copper | copper |
| Horizontal angle | ±2° | 35° | 13° | 0° |
| Vertical angle | ±2° | 30° | 40° | 145° |
| Position l/h/w | [mm] | 119/73/59 | 117/107/66 | -88/101/71 |
| | [in] | 4,7/2,9/2,3 | 4,6/4,2/2,6 | -3,5/4/2,8 |
| Straight tube l. | [mm] | 14 | 14 | 14 |
| | [in] | 0,5 | 0,5 | 0,5 |

Compressor fixation

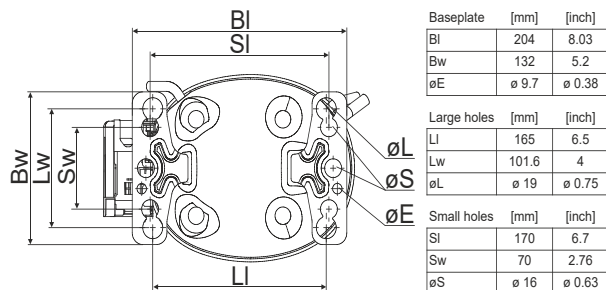

Bolt joint

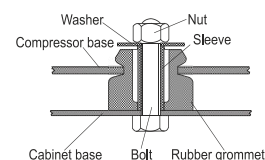

Snap-on

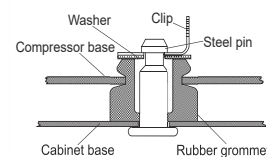

| Mounting accessories | one comp. | multi pack |
|----------------------------|-----------|------------|
| Bolt joint M6 ø16mm | 118-1917 | 118-1918 |
| Bolt joint ø1/4" ø16mm | 118-1946 | |
| Bolt joint ø1/4" ø19mm | 118-1949 | |
| Snap-on ø7,3 ø16mm | 118-1947 | 118-1919 |

Application notes

Provision for PE Grounding is located at the PE Stamp on the compressor

Model

| | | | | | |
|-------------|------------------|----------------------|----------------|-------------|-----------------|
| Designation | KLF4.8CNT | 200-240V/50Hz | Conf. 1 | Sales code: | 106H2512 |
|-------------|------------------|----------------------|----------------|-------------|-----------------|

Configuration

| | |
|------------------------|------------------|
| Motorconfiguration | CSIR |
| Power supply (nominal) | 200-240V/50Hz 1~ |
| Refrigerant | R290 |
| Application | LBP+MBP |
| Voltage range | 187-254V |
| Starting torque | HST |
| Approvals | UL |
| | CCC |
| | CB |

Electrical accessories / wiring diagram

CSIR

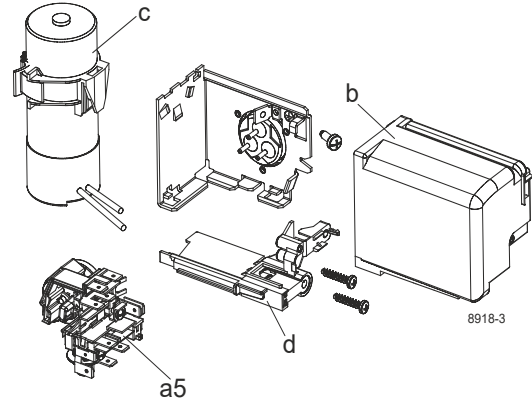

Ambient/ machine room temperatures minimum /maximum

| | |
|---------------------------------|------------------------|
| Ambient temperature range: | 10 - 43°C / 50 - 110°F |
| Machine room temperature range: | 10 - 48°C / 50 - 119°F |
| Compressor cooling: | fan 3m/s |

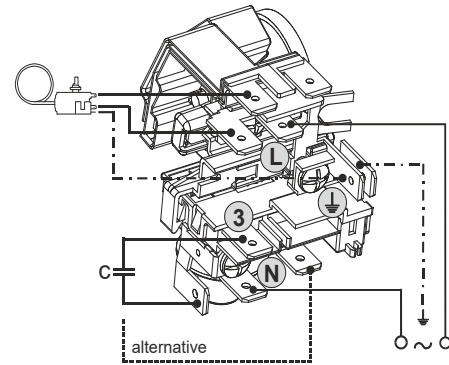

Operation pressure range

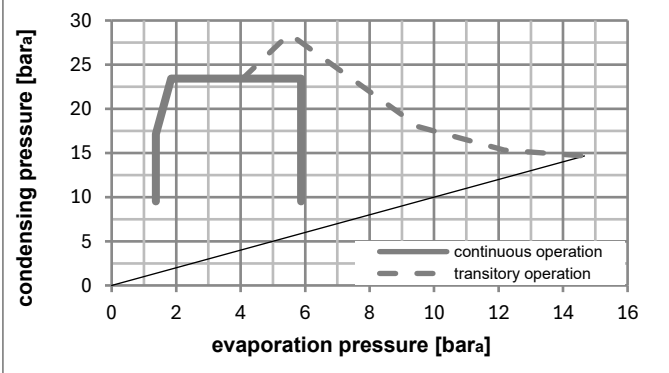
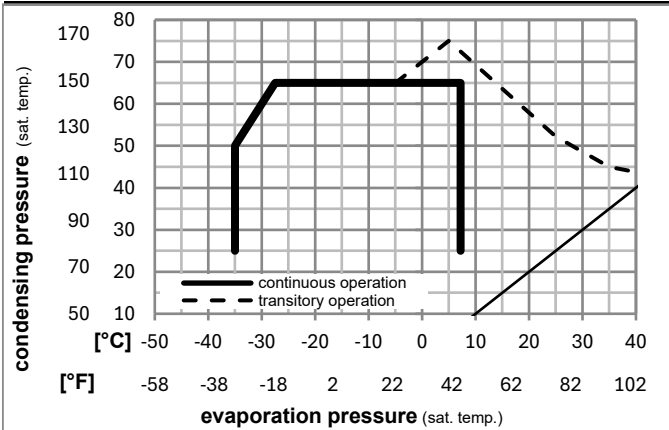

Components (already pre-assembled)

| | | |
|----|-------------------------------|----------|
| a5 | current relay (T0089/L6-S2) | 117U7070 |
| c | start capacitor (80µF, 6.3mm) | 117U5003 |
| b | cover terminal board | 10636401 |
| . | screw uni en iso 4757 | 10641201 |

Alternative comp. (already pre-assembled)

| | | |
|---|-----------------|----------|
| . | cable clamp | 16058100 |
| . | screw - uni6954 | 10636000 |
| . | screw - uni6954 | 10636200 |

Model

Designation **KLF4.8CNT** **200-240V/50Hz** Conf. 1 Sales code: **106H2512**

Optimization + standard conditions

R290, 220V/50Hz, CSIR, fan 3m/s, UL, CCC, CB

| | Evaporating pressure (saturation temperature) | | | | Condensing pressure (saturation temperature) | | | Return gas temp. | | | Liquid temp. | | | Cooling capacity | | | COP | EER | Power consumption | | |
|-------------|---|------|------|------|--|---------|----------|------------------|----------|-----------|--------------|------|----------------|------------------|--|--|-----|-----|-------------------|--|--|
| | pe | pc | RGT | Tliq | [W] | [Btu/h] | [kcal/h] | [W/W] | [Btu/Wh] | [kcal/Wh] | P1 | I | Ref. mass flow | | | | | | | | |
| | [°C] | [°C] | [°C] | [°C] | [W] | [Btu/h] | [kcal/h] | [W/W] | [Btu/Wh] | [kcal/Wh] | [W] | [A] | [kg/h] | | | | | | | | |
| ASHRAE LBP | -23 | 54 | 32 | 32 | 228,7 | 781 | 196,8 | 1,48 | 5,05 | 1,27 | 154,6 | 1,38 | 2,32 | | | | | | | | |
| | [°F] | [°F] | [°F] | [°F] | | | | | | | | | | | | | | | | | |
| ASHRAE LBP | -10 | 130 | 90 | 90 | | | | | | | | | | | | | | | | | |
| cecomaf LBP | -25 | 55 | 32 | 55 | 170,2 | 581 | 146,5 | 1,13 | 3,87 | 0,97 | 150,3 | 1,37 | 2,12 | | | | | | | | |
| | [°C] | [°C] | [°C] | [°C] | | | | | | | | | | | | | | | | | |
| cecomaf LBP | -13 | 131 | 90 | 131 | | | | | | | | | | | | | | | | | |
| | [°F] | [°F] | [°F] | [°F] | | | | | | | | | | | | | | | | | |
| EN12900 LBP | -35 | 40 | 20 | 40 | 131,9 | 450 | 113,5 | 1,08 | 3,69 | 0,93 | 122,1 | 1,33 | 1,51 | | | | | | | | |
| | [°C] | [°C] | [°C] | [°C] | | | | | | | | | | | | | | | | | |
| EN12900 LBP | -31 | 104 | 68 | 104 | | | | | | | | | | | | | | | | | |
| | [°F] | [°F] | [°F] | [°F] | | | | | | | | | | | | | | | | | |
| ASHRAE MBP | -7 | 54 | 35 | 46 | 420,2 | 1435 | 361,7 | 2,07 | 7,07 | 1,78 | 202,9 | 1,49 | 4,79 | | | | | | | | |
| | [°C] | [°C] | [°C] | [°C] | | | | | | | | | | | | | | | | | |
| ASHRAE MBP | 20 | 130 | 95 | 115 | | | | | | | | | | | | | | | | | |
| | [°F] | [°F] | [°F] | [°F] | | | | | | | | | | | | | | | | | |
| cecomaf MBP | -10 | 55 | 32 | 55 | 332,3 | 1135 | 286,0 | 1,71 | 5,83 | 1,47 | 194,6 | 1,47 | 4,20 | | | | | | | | |
| | [°C] | [°C] | [°C] | [°C] | | | | | | | | | | | | | | | | | |
| cecomaf MBP | 14 | 131 | 90 | 131 | | | | | | | | | | | | | | | | | |
| | [°F] | [°F] | [°F] | [°F] | | | | | | | | | | | | | | | | | |
| EN12900 MBP | -10 | 45 | 20 | 45 | 384,6 | 1314 | 331,0 | 2,14 | 7,29 | 1,84 | 180,1 | 1,43 | 4,72 | | | | | | | | |
| | [°C] | [°C] | [°C] | [°C] | | | | | | | | | | | | | | | | | |
| EN12900 MBP | 14 | 113 | 68 | 113 | | | | | | | | | | | | | | | | | |
| | [°F] | [°F] | [°F] | [°F] | | | | | | | | | | | | | | | | | |

Performance tables

R290, 220V/50Hz, CSIR, fan 3m/s, UL, CCC, CB

| | pe | | Cooling capacity | | | COP | EER | P1 | I | m | |
|------------------|------|------|------------------|---------|----------|-------|----------|-----------|-------|------|--------|
| | [°C] | [°F] | [W] | [Btu/h] | [kcal/h] | [W/W] | [Btu/Wh] | [kcal/Wh] | [W] | [A] | [kg/h] |
| [°C / °F] | -35 | -31 | 121,2 | 414 | 104,3 | 0,99 | 3,37 | 0,85 | 122,7 | 1,33 | 1,36 |
| cond. pressure | -25 | -13 | 211,4 | 722 | 181,9 | 1,45 | 4,95 | 1,25 | 145,9 | 1,36 | 2,38 |
| pc= 45/113 | -15 | 5 | 328,2 | 1121 | 282,5 | 1,94 | 6,63 | 1,67 | 169,0 | 1,41 | 3,73 |
| return gas temp. | -10 | 14 | 400,4 | 1367 | 344,6 | 2,22 | 7,59 | 1,91 | 180,1 | 1,43 | 4,58 |
| RGT= 32/90 | -5 | 23 | 483,7 | 1652 | 416,3 | 2,54 | 8,67 | 2,19 | 190,5 | 1,45 | 5,57 |
| liquid temp | 0 | 32 | 579,7 | 1980 | 498,9 | 2,90 | 9,89 | 2,49 | 200,2 | 1,48 | 6,72 |
| Tliq= 45/113 | 7,2 | 45 | 743,2 | 2538 | 639,6 | 3,50 | 11,96 | 3,01 | 212,3 | 1,51 | 8,73 |
| [°C / °F] | -35 | -31 | 90,2 | 308 | 77,6 | 0,74 | 2,53 | 0,64 | 121,6 | 1,32 | 1,12 |
| cond. pressure | -25 | -13 | 170,2 | 581 | 146,5 | 1,13 | 3,87 | 0,97 | 150,3 | 1,37 | 2,12 |
| pc= 55/131 | -15 | 5 | 270,6 | 924 | 232,9 | 1,50 | 5,14 | 1,29 | 179,9 | 1,43 | 3,40 |
| return gas temp | -10 | 14 | 332,3 | 1135 | 286,0 | 1,71 | 5,83 | 1,47 | 194,6 | 1,47 | 4,20 |
| RGT= 32/90 | -5 | 23 | 403,5 | 1378 | 347,3 | 1,93 | 6,59 | 1,66 | 209,0 | 1,50 | 5,14 |
| liquid temp | 0 | 32 | 485,8 | 1659 | 418,1 | 2,18 | 7,45 | 1,88 | 222,8 | 1,54 | 6,24 |
| Tliq= 55/131 | 7,2 | 45 | 626,9 | 2141 | 539,5 | 2,60 | 8,87 | 2,24 | 241,3 | 1,60 | 8,17 |

Model

| | | | | | |
|-------------|------------------|----------------------|----------------|-------------|-----------------|
| Designation | KLF4.8CNT | 208-230V/60Hz | Conf. 2 | Sales code: | 106H2512 |
|-------------|------------------|----------------------|----------------|-------------|-----------------|

Configuration

| | |
|------------------------|------------------|
| Motorconfiguration | CSIR |
| Power supply (nominal) | 208-230V/60Hz 1~ |
| Refrigerant | R290 |
| Application | LBP+MBP |
| Voltage range | 198-253V |
| Starting torque | HST |
| Approvals | UL |
| | CCC |
| | CB |
| | KC |

Electrical accessories / wiring diagram

CSIR

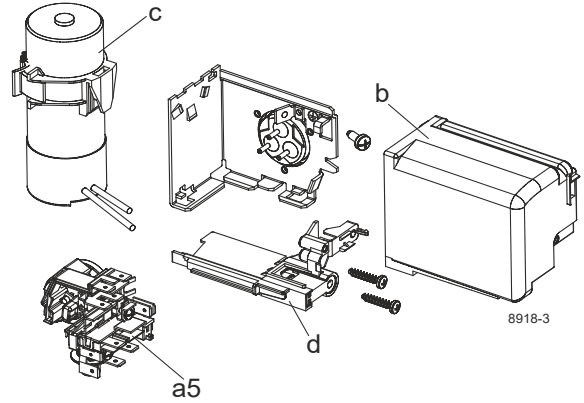

Ambient/ machine room temperatures minimum /maximum

| | |
|---------------------------------|------------------------|
| Ambient temperature range: | 10 - 43°C / 50 - 110°F |
| Machine room temperature range: | 10 - 48°C / 50 - 119°F |
| Compressor cooling: | fan 3m/s |

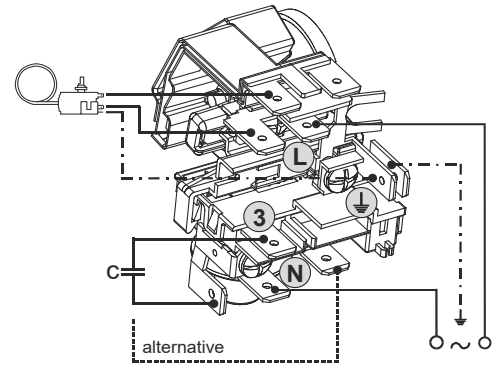

Operation pressure range

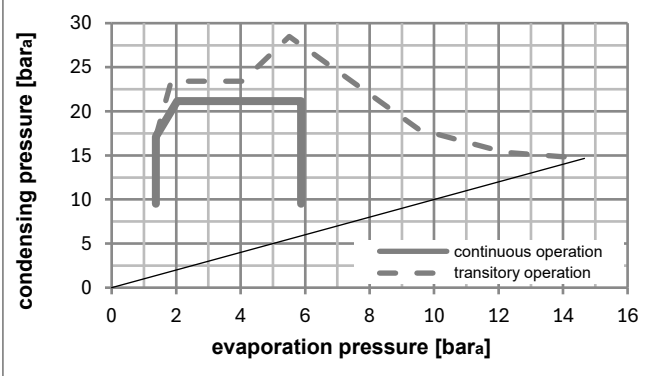
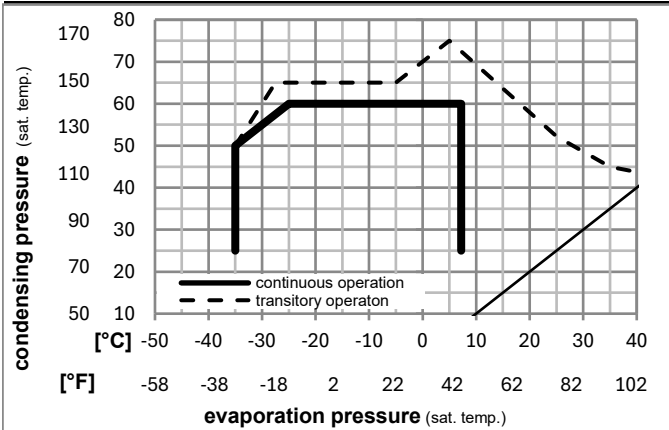

Components (already pre-assembled)

| | | |
|----|-------------------------------|----------|
| a5 | current relay (T0089/L6-S2) | 117U7070 |
| c | start capacitor (80µF, 6.3mm) | 117U5003 |
| b | cover terminal board | 10636401 |
| . | screw uni en iso 4757 | 10641201 |

Alternative comp. (already pre-assembled)

| | | |
|---|-----------------|----------|
| . | cable clamp | 16058100 |
| . | screw - uni6954 | 10636000 |
| . | screw - uni6954 | 10636200 |

Model

Designation **KLF4.8CNT** **208-230V/60Hz** Conf. 2 Sales code: **106H2512**

Optimization + standard conditions

R290, 230V/60Hz, CSIR, fan 3m/s, UL, CCC, CB, KC

| | Evaporating pressure (saturation temperature) | | | | Cooling capacity | COP | EER | Power consumption | | | ASHRAE LBP | | | |
|--|---|------|------|------|------------------|---------|----------|-------------------|----------|-----------|------------|------|--------|-------------|
| | pe | pc | RGT | Tliq | | | | P1 | I | m | | | | |
| | [°C] | [°F] | [°C] | [°F] | [W] | [Btu/h] | [kcal/h] | [W/W] | [Btu/Wh] | [kcal/Wh] | [W] | [A] | [kg/h] | |
| | -23 | 54 | 32 | 32 | 284,7 | 972 | 245,1 | 1,57 | 5,38 | 1,35 | 180,9 | 1,26 | 2,88 | ASHRAE LBP |
| | -10 | 130 | 90 | 90 | | | | | | | | | | |
| | -25 | 55 | 32 | 55 | 213,0 | 727 | 183,3 | 1,23 | 4,19 | 1,05 | 173,8 | 1,24 | 2,65 | cecomaf LBP |
| | -13 | 131 | 90 | 131 | | | | | | | | | | |
| | -35 | 40 | 20 | 40 | 160,5 | 548 | 138,2 | 1,19 | 4,07 | 1,03 | 134,7 | 1,14 | 1,83 | EN12900 LBP |
| | -31 | 104 | 68 | 104 | | | | | | | | | | |
| | -7 | 54 | 35 | 46 | 520,0 | 1776 | 447,5 | 2,09 | 7,13 | 1,80 | 249,1 | 1,47 | 5,93 | ASHRAE MBP |
| | 20 | 130 | 95 | 115 | | | | | | | | | | |
| | -10 | 55 | 32 | 55 | 411,0 | 1404 | 353,7 | 1,73 | 5,92 | 1,49 | 237,1 | 1,43 | 5,20 | cecomaf MBP |
| | 14 | 131 | 90 | 131 | | | | | | | | | | |
| | -10 | 45 | 20 | 45 | 462,7 | 1580 | 398,2 | 2,09 | 7,12 | 1,79 | 221,9 | 1,38 | 5,68 | EN12900 MBP |
| | 14 | 113 | 68 | 113 | | | | | | | | | | |

Performance tables

R290, 230V/60Hz, CSIR, fan 3m/s, UL, CCC, CB, KC

| | pe | | Cooling capacity | | | COP | EER | | P1 | I | m |
|------------------|------|------|------------------|---------|----------|-------|----------|-----------|-------|------|--------|
| | [°C] | [°F] | [W] | [Btu/h] | [kcal/h] | [W/W] | [Btu/Wh] | [kcal/Wh] | [W] | [A] | [kg/h] |
| [°C / °F] | -35 | -31 | 152,8 | 522 | 131,5 | 1,13 | 3,85 | 0,97 | 135,7 | 1,15 | 1,71 |
| cond. pressure | -25 | -13 | 253,2 | 865 | 217,9 | 1,48 | 5,05 | 1,27 | 171,1 | 1,23 | 2,86 |
| pc= 45/113 | -15 | 5 | 394,3 | 1347 | 339,3 | 1,91 | 6,53 | 1,65 | 206,1 | 1,33 | 4,49 |
| return gas temp. | -10 | 14 | 481,7 | 1645 | 414,6 | 2,17 | 7,41 | 1,87 | 221,9 | 1,38 | 5,51 |
| RGT= 32/90 | -5 | 23 | 581,2 | 1985 | 500,2 | 2,46 | 8,42 | 2,12 | 235,9 | 1,42 | 6,69 |
| liquid temp | 0 | 32 | 693,5 | 2369 | 596,9 | 2,80 | 9,57 | 2,41 | 247,4 | 1,46 | 8,04 |
| Tliq= 45/113 | 7,2 | 45 | 879,0 | 3002 | 756,5 | 3,40 | 11,61 | 2,92 | 258,6 | 1,50 | 10,33 |
| [°C / °F] | -35 | -31 | 130,2 | 445 | 112,0 | 0,98 | 3,36 | 0,85 | 132,4 | 1,14 | 1,61 |
| cond. pressure | -25 | -13 | 213,0 | 727 | 183,3 | 1,23 | 4,19 | 1,05 | 173,8 | 1,24 | 2,65 |
| pc= 55/131 | -15 | 5 | 334,3 | 1142 | 287,7 | 1,54 | 5,27 | 1,33 | 216,6 | 1,36 | 4,20 |
| return gas temp | -10 | 14 | 411,0 | 1404 | 353,7 | 1,73 | 5,92 | 1,49 | 237,1 | 1,43 | 5,20 |
| RGT= 32/90 | -5 | 23 | 499,3 | 1705 | 429,7 | 1,95 | 6,66 | 1,68 | 256,2 | 1,49 | 6,36 |
| liquid temp | 0 | 32 | 599,8 | 2048 | 516,2 | 2,19 | 7,49 | 1,89 | 273,3 | 1,55 | 7,70 |
| Tliq= 55/131 | 7,2 | 45 | 767,2 | 2620 | 660,2 | 2,61 | 8,93 | 2,25 | 293,4 | 1,62 | 9,99 |

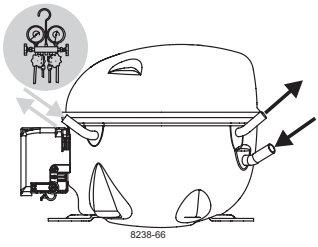

KL Compressors

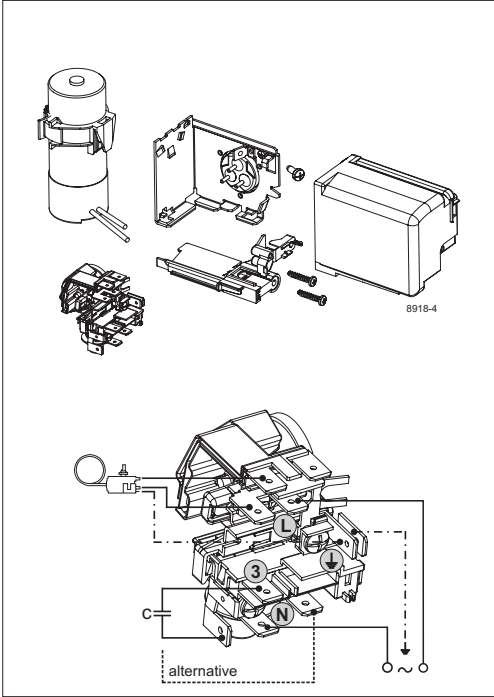
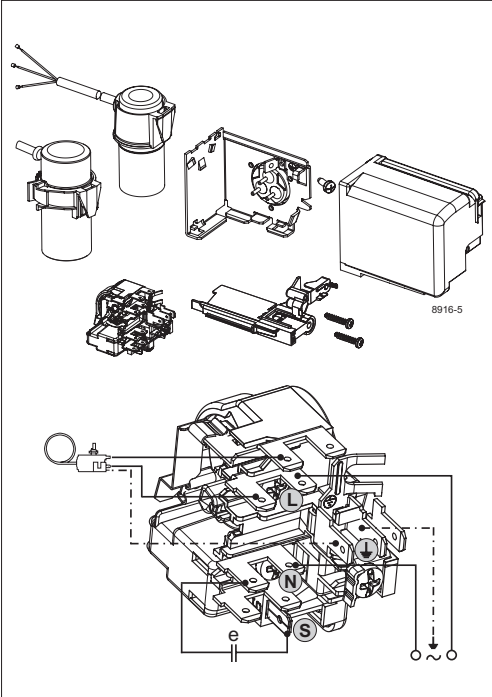
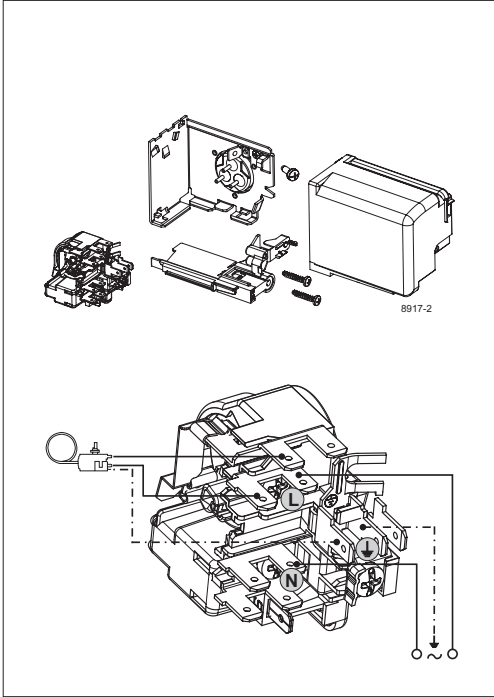

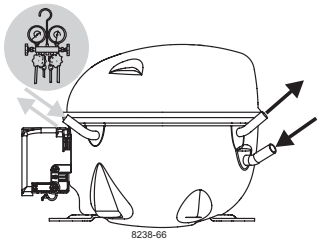

KL Compressors



Service/Repair – R290

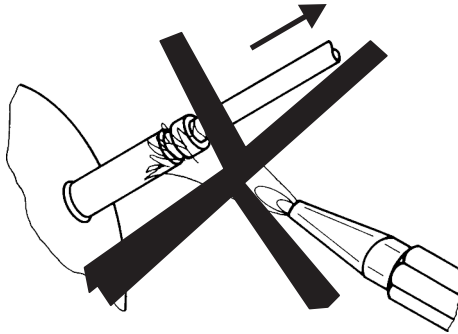

8545

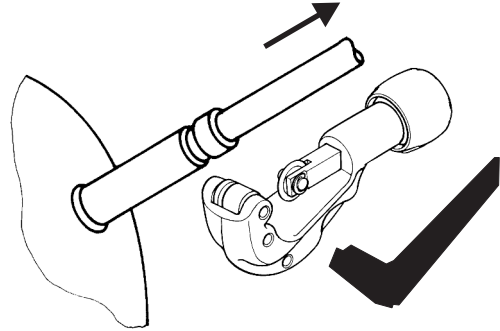

Secop accepts no responsibility for possible errors in catalogs, brochures, and other printed material. Secop reserves the right to alter its products without notice. This also applies to products already on order provided that such alterations can be made without subsequent changes being necessary to specifications already agreed. All trademarks in this material are the property of the respective companies. Secop and the Secop logotype are trademarks of Secop GmbH. All rights reserved. www.secop.com