

## BD80F Direct Current Compressor R134a 12/24V DC

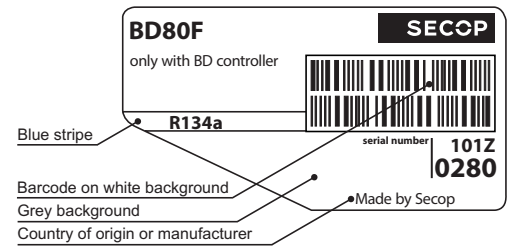

### General

Code number (without electronic units)	101Z0280
Electronic unit - High Speed	101N0390, 30 pcs: 101N0391
Compressors on pallet	150

### Application

Application	LBP
Evaporating temperature °C	-30 to -5
Voltage/max. voltage VDC	9.6 - 17 / 21.3 - 31.5
Max. condensing temperature continuous (short) °C	60 (70)
Max. winding temperature continuous (short) °C	125 (135)

### Cooling requirements

Application	LBP	MBP	HBP
32°C	S	-	-
38°C	S	-	-
43°C	S	-	-
Remarks on application:			

### Motor

Motor type	variable speed
Resistance, all 3 windings (25°C) Ω	1.8

### Design

Displacement cm <sup>3</sup>	3.00
Oil quantity (type) cm <sup>3</sup>	150 (polyolester)
Maximum refrigerant charge g	300
Free gas volume in compressor cm <sup>3</sup>	870
Weight - Compressor/Electronic unit kg	4.4/0.32

### Standard battery protection settings (refer to electronic unit Instructions for optional settings)

Voltage	12V	24V
Cut out VDC	10.4	22.8
Cut in VDC	11.7	24.2

### Dimensions

Height	mm	A	137
		B	135
		B1	128
		B2	73
Suction connector	location/I.D. mm   angle	C	6.2   40°
	material   comment	Cu-plated steel   Al cap	
Process connector	location/I.D. mm   angle	D	6.2   45°
	material   comment	Cu-plated steel   Al cap	
Discharge connector	location/I.D. mm   angle	E	5.0   21°
	material   comment	Cu-plated steel   Al cap	
Connector tolerance	I.D. mm	±0.09, on 5.0 +0.12/+0.20	
Remarks:			

- S = Static cooling normally sufficient
- O = Oil cooling
- F<sub>1</sub> = Fan cooling 1.5 m/s  
(compressor compartment temperature equal to ambient temperature)
- F<sub>2</sub> = Fan cooling 3.0 m/s necessary
- SG = Suction gas cooling normally sufficient
- = not applicable in this area

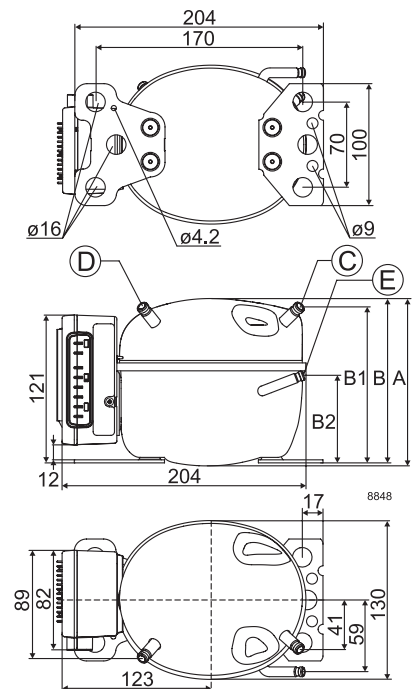

Capacity (EN 12900 Household/CECOMAF) 24V DC, static cooling watt												
rpm \ °C	-30	-25	-23.3	-20	-15	-10	-5	0	5	7.2	10	15
2,500	35.2	49.8	55.3	67.0	87.3	112	140					
3,100	41.9	59.2	65.8	79.8	104	133	168					
3,800	50.1	70.8	78.7	95.4	125	159	200					
4,400	54.9	78.1	86.8	105	138	176	221					

Capacity (ASHRAE LBP) 24V DC, static cooling watt												
rpm \ °C	-30	-25	-23.3	-20	-15	-10	-5	0	5	7.2	10	15
2,500	43.7	61.8	68.6	83.1	108	138	174					
3,100	52.0	73.4	81.6	98.8	129	165	208					
3,800	62.1	87.8	97.5	118	154	197	248					
4,400	68.1	96.7	108	130	171	218	274					

Power consumption 24V DC, static cooling watt												
rpm \ °C	-30	-25	-23.3	-20	-15	-10	-5	0	5	7.2	10	15
2,500	38.4	47.9	51.2	57.8	68.2	79.5	91.9					
3,100	46.9	58.9	62.9	70.8	83.4	97.3	113					
3,800	57.5	72.0	76.9	86.5	102	119	139					
4,400	66.3	83.5	89.2	100	118	138	161					

Current consumption (for 12V applications the following must be doubled) A												
rpm \ °C	-30	-25	-23.3	-20	-15	-10	-5	0	5	7.2	10	15
2,500	1.6	2.0	2.1	2.4	2.8	3.3	3.8					
3,100	1.9	2.4	2.6	3.0	3.5	4.1	4.7					
3,800	2.4	3.0	3.2	3.6	4.3	5.0	5.8					
4,400	2.8	3.5	3.7	4.2	4.9	5.8	6.7					

COP (EN 12900 Household/CECOMAF) 24V DC, static cooling W/W												
rpm \ °C	-30	-25	-23.3	-20	-15	-10	-5	0	5	7.2	10	15
2,500	0.92	1.04	1.08	1.16	1.28	1.40	1.53					
3,100	0.89	1.01	1.05	1.13	1.25	1.37	1.48					
3,800	0.87	0.98	1.02	1.10	1.22	1.34	1.44					
4,400	0.83	0.94	0.97	1.05	1.16	1.27	1.37					

COP (ASHRAE LBP) 24V DC, static cooling W/W												
rpm \ °C	-30	-25	-23.3	-20	-15	-10	-5	0	5	7.2	10	15
2,500	1.14	1.29	1.34	1.44	1.59	1.75	1.90					
3,100	1.10	1.25	1.30	1.40	1.55	1.70	1.85					
3,800	1.07	1.22	1.27	1.37	1.52	1.66	1.80					
4,400	1.02	1.16	1.21	1.30	1.45	1.58	1.71					

Test conditions	EN 12900/CECOMAF	ASHRAE LBP
Condensing temperature	55°C	54.4°C
Ambient temperature	32°C	32°C
Suction gas temperature	32°C	32°C
Liquid temperature	no subcooling	32°C

Accessories for BD80F	Code number
Bolt joint for one comp.	Ø:16 mm 118-1917
Bolt joint in quantities	Ø:16 mm 118-1918
Snap-on in quantities	Ø:16 mm 118-1919
Remote kit (without cable)	105N9210
Secop Gateway	105N9518
Automobile fuse, DIN 7258	12V: 30A   24V: 15 A
Main switch	min. 30A Not deliverable from Secop

Compressor speed	Resistor (R1) [Ω]	Motor speed
Code number	calculated values	[rpm]
<b>101N0390 with AEO</b>	0	AEO
	203	2,500
	451	3,100
	867	3,800
	1700	4,400

In AEO (Adaptive Energy Optimizing) speed mode the BD compressor will always adapt its speed to the actual cooling demand.

Size		Max. length* 12V operation		Max. length* 24V operation	
Cross section	AWG				
[mm²]	[Gauge]	[m]	[ft.]	[m]	[ft.]
6	10	2.5	8	5	16

\*Length between battery and electronic unit

Operational errors	Error type
	Can be read out in the software <b>TOOL4COOL®</b>
<b>6</b>	<b>Thermostat failure</b> (If the NTC thermistor is short-circuit or has no connection).
<b>5</b>	<b>Thermal cut-out of electronic unit</b> (If the refrigeration system has been too heavily loaded, or if the ambient temperature is high, the electronic unit will run too hot).
<b>4</b>	<b>Minimum motor speed error</b> (If the refrigeration system is too heavily loaded, the motor cannot maintain minimum speed at approximately 1,850 rpm).
<b>3</b>	<b>Motor start error</b> (The rotor is blocked or the differential pressure in the refrigeration system is too high (>5 bar)).
<b>2</b>	<b>Too many start attempts or fan over current</b> (Too many compressor or fan starts in short time or fan current higher than 0.5A <sub>avg</sub> ).
<b>1</b>	<b>Battery protection cut-out</b> (The voltage is outside the cut-out setting).

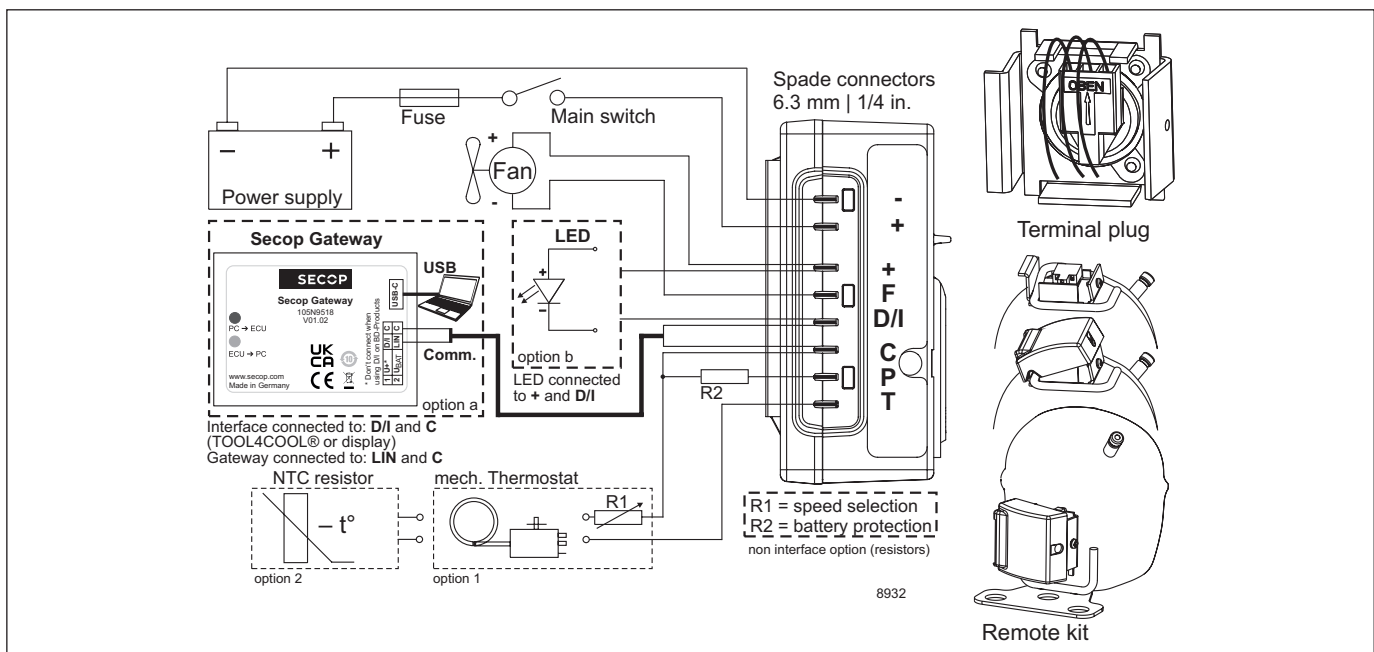

Secop accepts no responsibility for possible errors in catalogs, brochures, and other printed material. Secop reserves the right to alter its products without notice. This also applies to products already on order provided that such alterations can be made without consequential changes being necessary to specifications already agreed. All trademarks in this material are the property of the respective companies. Secop and the Secop logotype are trademarks of Secop GmbH. All rights reserved. [www.secop.com](http://www.secop.com)