

## Model

Designation	<b>HXK87AT</b>	<b>220-240V/50Hz 1~</b>	Sales code:	<b>16408900</b>
-------------	----------------	-------------------------	-------------	-----------------

## Compressor design

Oil type	Mineral	Refrigerant(s)	<b>R600a</b>
Oil viscosity	5cST	Displacement	8,8cm <sup>3</sup> / 0,54cu.in
Oil quantity	162cm <sup>3</sup> / 5,5fl.oz	Compressors on pallet	100
Refr. charge - tech. limit	150g / 5,3oz		
Free gas volume comp.	1620cm <sup>3</sup> / 54,8fl.oz		
Weight	8,6kg / 19lbs		
Motor protection	external		
Winding resistance main	18,8Ω (at 25°C)		
Winding resistance aux	10,7Ω (at 25°C)		
Max. winding temp.	130°C / 266°F		
Max. discharge temp.	130°C / 266°F		



## General - Configurations with HXK87AT

	<b>Conf. 1</b>	<b>Conf. 2</b>	<b>Conf. 3</b>	<b>Conf. 4</b>
Motorconfiguration	RSCR	RSIR	RSCR	RSCR
Power supply (nominal)	200-240V/50Hz	200-240V/50Hz	220-240V/50Hz	208-230V/60Hz
Number of phases	1	1	1	1
Voltage range	170-264V	170-264V	170-264V	198-253V
Approvals	VDE	VDE	VDE	VDE
Starting torque	LST	LST	LST	LST
Note	Various options of connectors are possible - please contact SECOP-Sales.			

## Applications with HXK87AT

	<b>Conf. 1</b>	<b>Conf. 2</b>	<b>Conf. 3</b>	<b>Conf. 4</b>
Refrigerant	R600a	R600a	R600a	R600a
Application	LBP	LBP	LBP	LBP
System cooling	static	static	static	static
Hot gas defrost	-/-	-/-	-/-	-/-
Long interval pull down	-/-	-/-	-/-	-/-

## Electrical data - Configurations with HXK87AT

	<b>Conf. 1</b>	<b>Conf. 2</b>	<b>Conf. 3</b>	<b>Conf. 4</b>
Starting device type	PTC	PTC	PTC	PTC
Run capacitor	4μF	-/-	4μF	4μF
Start capacitor	-/-	-/-	-/-	-/-
LRA (locked rotor amps / 4s/ U(N))				
RLA (rated load amps / 1s/ U(N))	-/-A	-/-A		-/-A
Cut in current (U(N))				

## Model

Designation	<b>HXK87AT</b>	220-240V/50Hz 1~	Sales code:	<b>16408900</b>
-------------	----------------	------------------	-------------	-----------------

## Compressor dimensions

<b>Housing</b>	A Height	174mm / 6,85in
	B Height	167mm / 6,57in
	C Length shell	194mm / 7,64in
	D Length w. cover	238mm / 9,37in
	E Width	151mm / 5,94in

<b>Connectors</b>		<b>Suction</b>	<b>Discharge</b>	<b>Process</b>
		<b>X</b>	<b>Y</b>	<b>Z</b>
Diameter	[mm]	øi 6,1-6,2	øi 5,1-5,2	øo 5,92-6,08
	(i:inside, o:outside) [in]	øi 0,24-0,24	øi 0,2-0,2	øo 0,23-0,24
Material		copper	copper	copper
Horizontal angle	±2°	45°	13°	0°
Vertical angle	±2°	30°	40°	145°
Position l/h/w	[mm]	120/72/62	112/106/62	-140/136/70
	[in]	4,7/2,8/2,4	4,4/4,2/2,4	-5,5/5,4/2,8
Straight tube l.	[mm]	14	14	75
	[in]	0,5	0,5	3

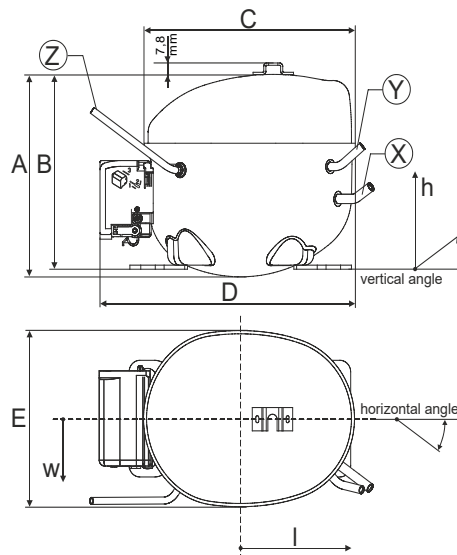

## Compressor fixation

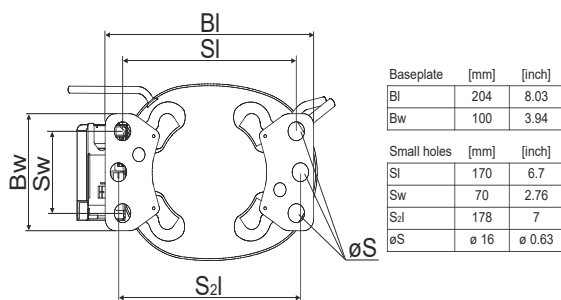

## Bolt joint

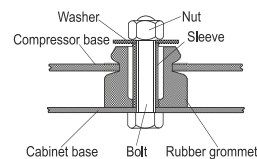

## Snap-on

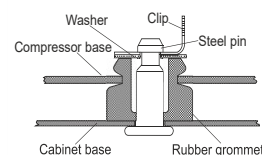

## Mounting accessories

'4ZN' with rubber grommet	order code	772N
'4ZN' with rubber grommet and sleeve for M6		768N
Bolt joint kit		4ZN + 118-1917 (18)
'4ZN' with Snap on kit		776N

## Application notes

Provision for PE Grounding is located at the PE Stamp on the compressor Housing with dip-tray fixture (omega bracket).  
 Various options of connectors are possible - please contact SECOP-Sales.

## Model

Designation	<b>HXK87AT</b>	<b>200-240V/50Hz</b>	Conf. 1	Sales code:	<b>16408900</b>
-------------	----------------	----------------------	---------	-------------	-----------------

## Configuration

Motorconfiguration	RSCR
Power supply (nominal)	200-240V/50Hz 1~
Refrigerant	R600a
Application	LBP
Voltage range	170-264V
Starting torque	LST
Approvals	VDE

## Electrical accessories / wiring diagram

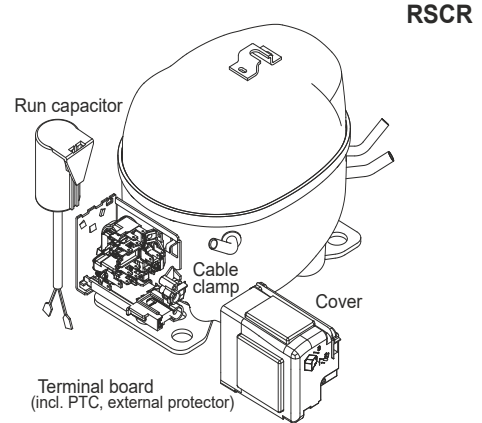

## Ambient/ machine room temperatures minimum /maximum

Ambient temperature range:	10 - 43°C / 50 - 110°F
Machine room temperature range:	10 - 48°C / 50 - 119°F
Compressor cooling:	static

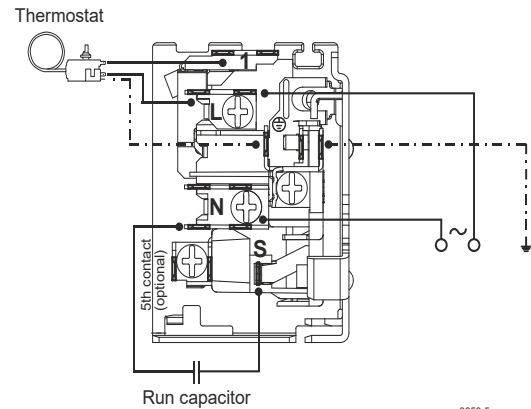

## Operation pressure range

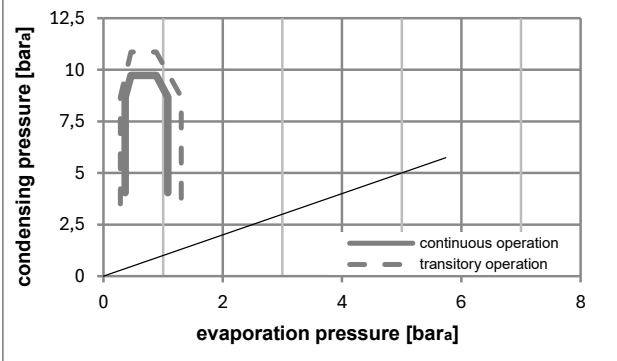
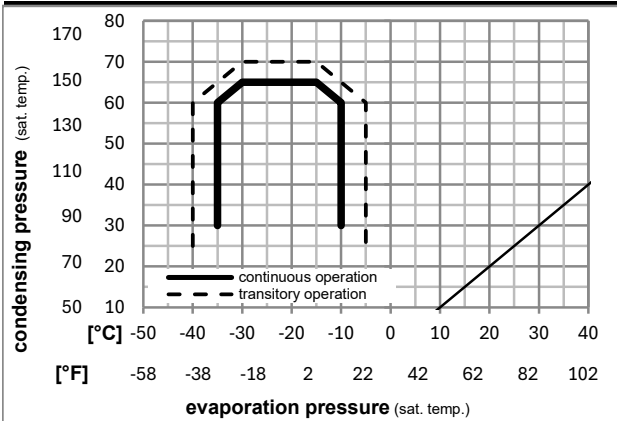

## Components

. terminal board (PTC, 6.3mm)	16403700
. run capacitor (4μF, 6.3mm)	15186801
b cover terminal board	10636401
. cable clamp	11341000
. screw - uni6954	10636000
. screw - uni6954	10636200

## Alternative components

. screw uni en iso 4757	10641201
-------------------------	----------

### Model

Designation **HXK87AT** **200-240V/50Hz** Conf. 1 Sales code: **16408900**

### Optimization + standard conditions

R600a, 200V/50Hz, RSCR, static, VDE

Evaporating pressure (saturation temperature)				Condensing pressure (saturation temperature)			Return gas temp.			Liquid temp.			Cooling capacity			COP	EER	Power consumption			ASHRAE LBP
pe	pc	RGT	Tliq	[W]	[Btu/h]	[kcal/h]	[W/W]	[Btu/Wh]	[kcal/Wh]	P1	I	m	[W]	[A]	[kg/h]	Current consumption					
[°C]	[°C]	[°C]	[°C]	[W]	[Btu/h]	[kcal/h]	[W/W]	[Btu/Wh]	[kcal/Wh]	[W]	[A]	[kg/h]	[W]	[A]	[kg/h]						
-23	54	32	32	153,8	525	132,3	1,75	5,97	1,50	88,0	0,45	1,65							ASHRAE LBP		
-10	130	90	90																		
-25	55	32	55	115,9	396	99,8	1,37	4,67	1,18	84,7	0,43	1,51							cecomaf LBP		
-13	131	90	131																		
-35	40	20	40	90,6	309	77,9	1,37	4,70	1,18	65,9	0,31	1,10							EN12900 LBP		
-31	104	68	104																		
-23	49	4,4	49	124,2	424	106,9	1,45	4,96	1,25	85,6	0,45	1,81							ARI540 LBP		
-10	120	40	120																		
-23	41	32	32	161,5	552	139,0	1,99	6,78	1,71	81,3	0,43	1,73							AHAM LBP		
-10	105	90	90																		
-35	45	32	45	87,9	300	75,7	1,31	4,48	1,13	67,1	0,29	1,04							opt		
-31	113	90	113																		

### Performance tables

R600a, 200V/50Hz, RSCR, static, VDE

	pe		Cooling capacity			COP	EER	P1			I	m
	[°C]	[°F]	[W]	[Btu/h]	[kcal/h]	[W/W]	[Btu/Wh]	[kcal/Wh]	[W]	[A]	[kg/h]	
[°C / °F]	-35	-31	87,9	300	75,7	1,31	4,48	1,13	67,1	0,29	1,04	
cond. pressure	-30	-22	105,3	360	90,6	1,44	4,93	1,24	73,0	0,37	1,25	
pc= 45/113	-25	-13	132,5	452	114,0	1,64	5,60	1,41	80,7	0,42	1,58	
return gas temp.	-23	-10	143,8	491	123,8	1,72	5,87	1,48	83,7	0,44	1,71	
RGT= 32/90	-20	-4	168,8	576	145,2	1,88	6,42	1,62	89,8	0,47	2,01	
liquid temp	-15	5	213,5	729	183,7	2,14	7,31	1,84	99,8	0,51	2,55	
Tliq= 45/113	-10	14	265,8	908	228,8	2,41	8,24	2,08	110,1	0,55	3,18	
[°C / °F]	-35	-31	72,2	247	62,1	1,07	3,67	0,92	67,2	0,25	0,94	
cond. pressure	-30	-22	90,1	308	77,6	1,20	4,10	1,03	75,1	0,36	1,17	
pc= 55/131	-25	-13	115,9	396	99,8	1,37	4,67	1,18	84,7	0,43	1,51	
return gas temp	-23	-10	126,3	432	108,7	1,43	4,89	1,23	88,3	0,46	1,65	
RGT= 32/90	-20	-4	148,8	508	128,1	1,56	5,32	1,34	95,6	0,49	1,94	
liquid temp	-15	5	188,2	643	162,0	1,76	6,00	1,51	107,2	0,55	2,46	
Tliq= 55/131	-10	14	233,3	797	200,8	1,96	6,69	1,69	119,0	0,59	3,06	

## Model

Designation **HXK87AT** **200-240V/50Hz** Conf. 2 Sales code: **16408900**

## Configuration

## Electrical accessories / wiring diagram

Motorconfiguration RSIR  
 Power supply (nominal) 200-240V/50Hz 1~  
 Refrigerant R600a  
 Application LBP  
 Voltage range 170-264V  
 Starting torque LST  
 Approvals VDE

## Ambient/ machine room temperatures minimum /maximum

Ambient temperature range: 10 - 43°C / 50 - 110°F  
 Machine room temperature range: 10 - 48°C / 50 - 119°F  
 Compressor cooling: static

## Operation pressure range

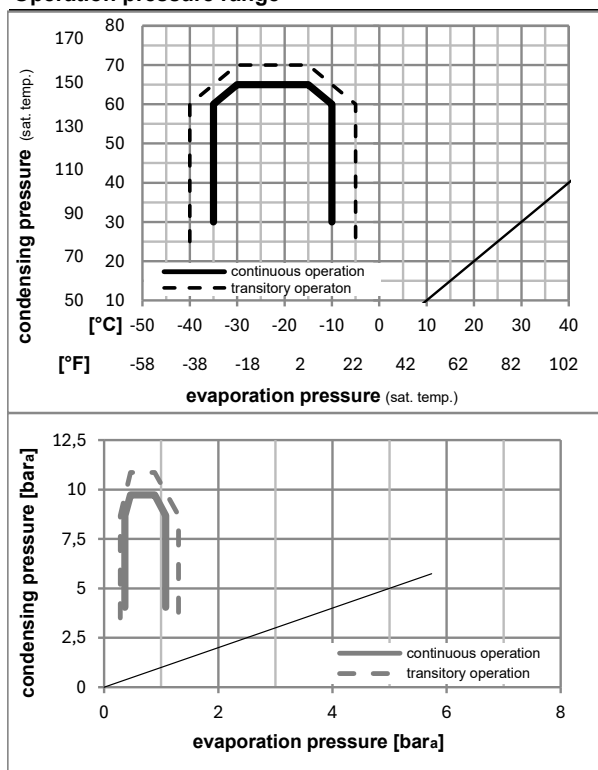

## Components

- . terminal board (PTC, 6.3mm) 16403700
- b cover terminal board 10636401
- . cable clamp 11341000
- . screw - uni6954 10636000
- . screw - uni6954 10636200
- . screw uni en iso 4757 10641201

## Model

Designation	<b>HXK87AT</b>	<b>200-240V/50Hz</b>	<b>Conf. 2</b>	Sales code:	<b>16408900</b>
-------------	----------------	----------------------	----------------	-------------	-----------------

## Optimization + standard conditions

R600a, 200V/50Hz, RSIR, static, VDE

		Evaporating pressure (saturation temperature)				Condensing pressure (saturation temperature)			Return gas temp.		Liquid temp.		Cooling capacity			COP	EER	Power consumption		Current consumption		Ref. mass flow	
		pe	pc	RGT	Tliq	[W]	[Btu/h]	[kcal/h]	[W/W]	[Btu/Wh]	[kcal/Wh]	[W]	I	m			[W]	[A]	[kg/h]				
[°C]	[°F]	[°C]	[°F]	[°C]	[°C]																		
-23	-10	54	130	32	32	153,7	525	132,3	1,67	5,70	1,44	92,2	0,48	1,65								ASHRAE LBP	
-25	-13	55	131	32	55	115,9	396	99,7	1,31	4,46	1,12	88,7	0,45	1,51								cecomaf LBP	
-35	-31	40	104	20	40	90,5	309	77,9	1,31	4,48	1,13	69,0	0,32	1,10								EN12900 LBP	
-23	-10	49	120	4,4	49	124,2	424	106,9	1,39	4,73	1,19	89,6	0,47	1,81								ARI540 LBP	
-23	-10	41	105	32	32	161,5	551	138,9	1,90	6,47	1,63	85,2	0,45	1,73								AHAM LBP	
-35	-31	45	113	32	45	87,9	300	75,7	1,25	4,27	1,08	70,3	0,31	1,04								opt	

## Performance tables

R600a, 200V/50Hz, RSIR, static, VDE

	pe		Cooling capacity			COP	EER	P1			I	m
	[°C]	[°F]	[W]	[Btu/h]	[kcal/h]	[W/W]	[Btu/Wh]	[kcal/Wh]	[W]	[A]	[kg/h]	
[°C / °F]	-35	-31	87,9	300	75,7	1,25	4,27	1,08	70,3	0,31	1,04	
cond. pressure	-30	-22	105,3	360	90,6	1,38	4,70	1,19	76,4	0,39	1,25	
pc= 45/113	-25	-13	132,4	452	114,0	1,57	5,35	1,35	84,5	0,44	1,58	
return gas temp.	-23	-10	143,8	491	123,7	1,64	5,60	1,41	87,6	0,46	1,71	
RGT= 32/90	-20	-4	168,7	576	145,2	1,79	6,13	1,54	94,1	0,49	2,01	
liquid temp	-15	5	213,4	729	183,7	2,04	6,98	1,76	104,5	0,53	2,55	
Tliq= 45/113	-10	14	265,8	908	228,7	2,30	7,87	1,98	115,3	0,58	3,18	
[°C / °F]	-35	-31	72,2	246	62,1	1,03	3,50	0,88	70,4	0,26	0,94	
cond. pressure	-30	-22	90,1	308	77,5	1,15	3,91	0,99	78,7	0,37	1,17	
pc= 55/131	-25	-13	115,9	396	99,7	1,31	4,46	1,12	88,7	0,45	1,51	
return gas temp	-23	-10	126,3	431	108,7	1,37	4,67	1,18	92,5	0,48	1,65	
RGT= 32/90	-20	-4	148,8	508	128,1	1,49	5,08	1,28	100,1	0,52	1,94	
liquid temp	-15	5	188,2	643	161,9	1,68	5,73	1,44	112,2	0,57	2,46	
Tliq= 55/131	-10	14	233,2	797	200,7	1,87	6,39	1,61	124,6	0,62	3,06	

## Model

Designation	<b>HXK87AT</b>	<b>220-240V/50Hz</b>	<b>Conf. 3</b>	Sales code:	<b>16408900</b>
-------------	----------------	----------------------	----------------	-------------	-----------------

## Configuration

Motorconfiguration	RSCR
Power supply (nominal)	220-240V/50Hz 1~
Refrigerant	R600a
Application	LBP
Voltage range	170-264V
Starting torque	LST
Approvals	VDE

## Electrical accessories / wiring diagram

**RSCR**

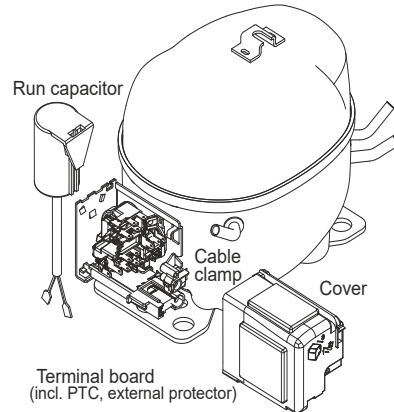

## Ambient/ machine room temperatures minimum /maximum

Ambient temperature range:	10 - 43°C / 50 - 110°F
Machine room temperature range:	10 - 48°C / 50 - 119°F
Compressor cooling:	static

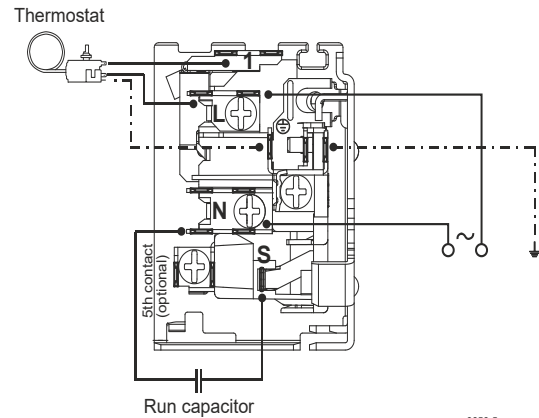

## Operation pressure range

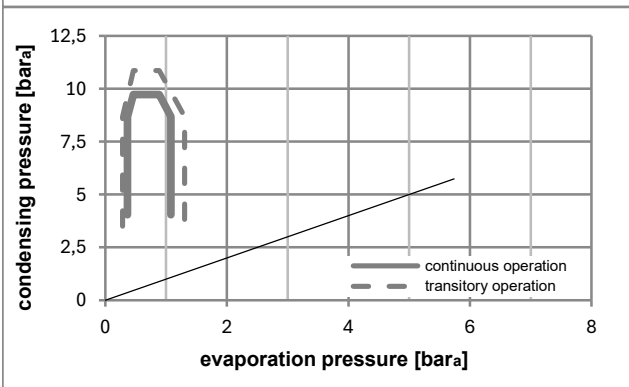
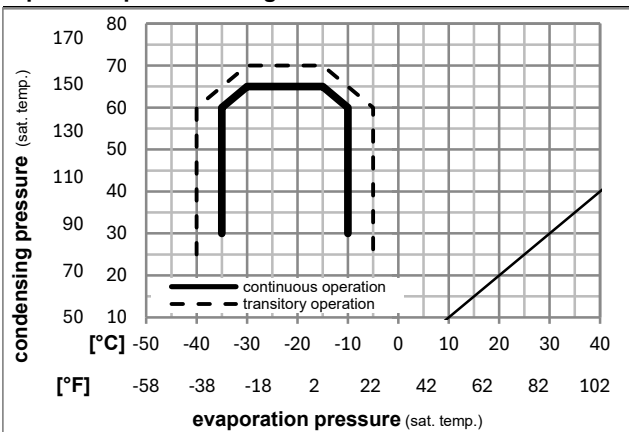

## Components

. terminal board (PTC, 6.3mm)	16403700
. run capacitor (4μF, 6.3mm)	15186801
b cover terminal board	10636401
. cable clamp	11341000
. screw - uni6954	10636000
. screw - uni6954	10636200

## Alternative components

. screw uni en iso 4757	10641201
-------------------------	----------

### Model

Designation	<b>HXK87AT</b>	<b>220-240V/50Hz</b>	Conf. 3	Sales code:	<b>16408900</b>
-------------	----------------	----------------------	---------	-------------	-----------------

### Optimization + standard conditions

R600a, 220V/50Hz, RSCR, static, VDE

	pe	pc	RGT	Tliq	Cooling capacity	COP	EER	P1	I	Ref. mass flow	
	[°C]	[°C]	[°C]	[°C]	[W]	[W/W]	[Btu/Wh]	[W]	[A]	[kg/h]	
Evaporating pressure (saturation temperature)	-23	54	32	32	154,9	1,71	5,84	90,5	0,47	1,66	ASHRAE LBP
Condensing pressure (saturation temperature)	-10	130	90	90	529	1,71	5,84	90,5	0,47	1,66	ASHRAE LBP
Return gas temp.					133,3	1,71	5,84	90,5	0,47	1,66	ASHRAE LBP
Liquid temp.					154,9	1,71	5,84	90,5	0,47	1,66	ASHRAE LBP
Power consumption					154,9	1,71	5,84	90,5	0,47	1,66	ASHRAE LBP
Current consumption					154,9	1,71	5,84	90,5	0,47	1,66	ASHRAE LBP
Ref. mass flow					154,9	1,71	5,84	90,5	0,47	1,66	ASHRAE LBP
	[°F]	[°F]	[°F]	[°F]	[Btu/h]	[W/W]	[Btu/Wh]	[W]	[A]	[kg/h]	
	-10	130	90	90	529	1,71	5,84	90,5	0,47	1,66	ASHRAE LBP
					133,3	1,34	4,58	87,1	0,45	1,52	cecomaf LBP
					116,7	1,34	4,58	87,1	0,45	1,52	cecomaf LBP
					100,5	1,34	4,58	87,1	0,45	1,52	cecomaf LBP
					91,2	1,35	4,60	67,7	0,32	1,11	EN12900 LBP
					312	1,35	4,60	67,7	0,32	1,11	EN12900 LBP
					78,5	1,35	4,60	67,7	0,32	1,11	EN12900 LBP
					125,1	1,42	4,85	88,0	0,46	1,83	ARI540 LBP
					427	1,42	4,85	88,0	0,46	1,83	ARI540 LBP
					107,7	1,42	4,85	88,0	0,46	1,83	ARI540 LBP
					162,7	1,94	6,64	83,6	0,44	1,75	AHAM LBP
					555	1,94	6,64	83,6	0,44	1,75	AHAM LBP
					140,0	1,94	6,64	83,6	0,44	1,75	AHAM LBP
					88,6	1,28	4,38	69,0	0,30	1,05	opt
					302	1,28	4,38	69,0	0,30	1,05	opt
					76,2	1,28	4,38	69,0	0,30	1,05	opt

### Performance tables

R600a, 220V/50Hz, RSCR, static, VDE

	pe	pc	RGT	Tliq	Cooling capacity	COP	EER	P1	I	m
	[°C]	[°C]	[°C]	[°C]	[W]	[W/W]	[Btu/Wh]	[W]	[A]	[kg/h]
[°C / °F]	-35	-31	45	45	88,6	1,28	4,38	69,0	0,30	1,05
cond. pressure	-30	-22	45	45	106,0	1,41	4,83	75,0	0,38	1,26
pc= 45/113	-25	-13	45	45	133,4	1,61	5,49	83,0	0,44	1,59
return gas temp.	-23	-10	45	45	144,9	1,68	5,75	86,0	0,45	1,73
RGT= 32/90	-20	-4	45	45	170,0	1,84	6,29	92,3	0,48	2,03
liquid temp	-15	5	45	45	215,0	2,10	7,16	102,6	0,52	2,57
Tliq= 45/113	-10	14	45	45	267,7	2,36	8,08	113,2	0,57	3,21
[°C / °F]	-35	-31	55	55	72,7	1,05	3,59	69,1	0,26	0,95
cond. pressure	-30	-22	55	55	90,8	1,18	4,01	77,2	0,37	1,18
pc= 55/131	-25	-13	55	55	116,7	1,34	4,58	87,1	0,45	1,52
return gas temp	-23	-10	55	55	127,3	1,40	4,79	90,8	0,47	1,66
RGT= 32/90	-20	-4	55	55	149,9	1,53	5,21	98,3	0,51	1,96
liquid temp	-15	5	55	55	189,6	1,72	5,88	110,2	0,56	2,48
Tliq= 55/131	-10	14	55	55	235,0	1,92	6,56	122,4	0,61	3,08



## Model

Designation	<b>HXK87AT</b>	<b>208-230V/60Hz</b>	<b>Conf. 4</b>	Sales code:	<b>16408900</b>
-------------	----------------	----------------------	----------------	-------------	-----------------

## Configuration

Motorconfiguration	RSCR
Power supply (nominal)	208-230V/60Hz 1~
Refrigerant	R600a
Application	LBP
Voltage range	198-253V
Starting torque	LST
Approvals	VDE

## Electrical accessories / wiring diagram

**RSCR**

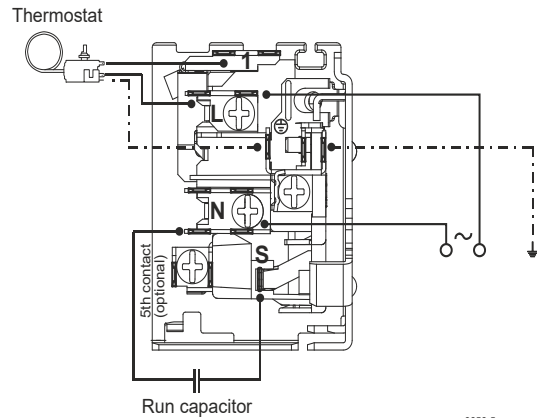
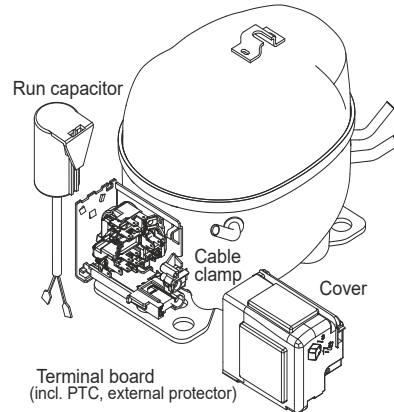

8858-5

## Ambient/ machine room temperatures minimum /maximum

Ambient temperature range:	10 - 43°C / 50 - 110°F
Machine room temperature range:	10 - 48°C / 50 - 119°F
Compressor cooling:	static

## Operation pressure range

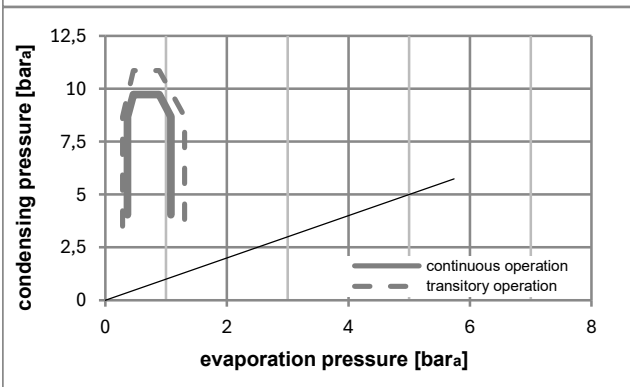
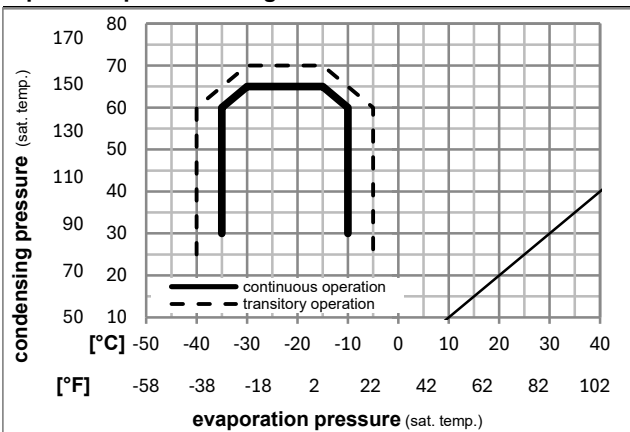

## Components

. terminal board (PTC, 6.3mm)	16403700
. run capacitor (4μF, 6.3mm)	15186801
b cover terminal board	10636401
. cable clamp	11341000
. screw - uni6954	10636000
. screw - uni6954	10636200

## Alternative components

. screw uni en iso 4757	10641201
-------------------------	----------

### Model

Designation	<b>HXK87AT</b>	<b>208-230V/60Hz</b>	<b>Conf. 4</b>	Sales code:	<b>16408900</b>
-------------	----------------	----------------------	----------------	-------------	-----------------

### Optimization + standard conditions

R600a, 220V/60Hz, RSCR, static, VDE

	Evaporating pressure (saturation temperature)				Cooling capacity			COP	EER	P1	Power consumption		ASHRAE LBP	
	pe	pc	RGT	Tliq	[W]	[Btu/h]	[kcal/h]				I	Ref. mass flow		
[°C]	[°F]	[°C]	[°F]	[°C]	[°F]	[°C]	[°F]	[W/W]	[Btu/Wh]	[kcal/Wh]	[W]	[A]	[kg/h]	
	-23	54	32	32	183,6	627	158,0	1,77	6,04	1,52	103,9	0,54	1,97	ASHRAE LBP
	-10	130	90	90										
	-25	55	32	55	138,5	473	119,2	1,38	4,73	1,19	100,0	0,51	1,81	cecomaf LBP
	-13	131	90	131										
	-35	40	20	40	106,9	365	92,0	1,38	4,70	1,18	77,7	0,36	1,30	EN12900 LBP
	-31	104	68	104										
	-23	49	4,4	49	147,8	505	127,2	1,46	5,00	1,26	101,0	0,53	2,16	ARI540 LBP
	-10	120	40	120										
	-23	41	32	32	190,7	651	164,1	1,99	6,78	1,71	96,0	0,51	2,05	AHAM LBP
	-10	105	90	90										
	-35	45	32	45	104,5	357	90,0	1,32	4,51	1,14	79,2	0,35	1,24	opt
	-31	113	90	113										

### Performance tables

R600a, 220V/60Hz, RSCR, static, VDE

	pe		Cooling capacity			COP	EER		P1	I	m
	[°C]	[°F]	[W]	[Btu/h]	[kcal/h]		[Btu/Wh]	[kcal/Wh]			
[°C / °F]	-35	-31	104,5	357	90,0	1,32	4,51	1,14	79,2	0,35	1,24
cond. pressure	-30	-22	124,9	426	107,5	1,45	4,95	1,25	86,2	0,43	1,48
pc= 45/113	-25	-13	157,0	536	135,1	1,65	5,63	1,42	95,3	0,50	1,87
return gas temp.	-23	-10	170,4	582	146,6	1,72	5,89	1,48	98,8	0,52	2,03
RGT= 32/90	-20	-4	199,9	683	172,1	1,89	6,44	1,62	106,0	0,55	2,38
liquid temp	-15	5	253,0	864	217,7	2,15	7,34	1,85	117,8	0,60	3,02
Tliq= 45/113	-10	14	315,2	1076	271,2	2,42	8,28	2,09	130,0	0,65	3,77
[°C / °F]	-35	-31	87,0	297	74,9	1,10	3,75	0,94	79,3	0,30	1,13
cond. pressure	-30	-22	108,0	369	93,0	1,22	4,16	1,05	88,7	0,42	1,41
pc= 55/131	-25	-13	138,5	473	119,2	1,38	4,73	1,19	100,0	0,51	1,81
return gas temp	-23	-10	150,9	515	129,8	1,45	4,94	1,25	104,2	0,54	1,97
RGT= 32/90	-20	-4	177,6	606	152,8	1,57	5,38	1,35	112,8	0,58	2,32
liquid temp	-15	5	224,4	766	193,1	1,77	6,06	1,53	126,5	0,64	2,94
Tliq= 55/131	-10	14	278,2	950	239,4	1,98	6,76	1,70	140,5	0,70	3,65