

## Model

Designation	<b>KLF4.0CND</b>	220-240V/50Hz 1~	Sales code:	<b>106H2411</b>
-------------	------------------	------------------	-------------	-----------------

## Compressor design

Oil type	Polyolester	Refrigerant(s)	<b>R290</b>
Oil viscosity	9,7cST	Displacement	4cm <sup>3</sup> / 0,24cu.in
Oil quantity	170cm <sup>3</sup> / 5,7fl.oz	Compressors on pallet	100
Refr. charge - tech. limit	200g / 7,1oz		
Free gas volume comp.	1630cm <sup>3</sup> / 55,1fl.oz		
Weight	8,95kg / 19,7lbs		
Motor protection	external		
Winding resistance main	13,1Ω (at 25°C)		
Winding resistance aux	25,3Ω (at 25°C)		
Max. winding temp.	125°C / 257°F		
Max. discharge temp.	130°C / 266°F		



## General - Configurations with KLF4.0CND

	<b>Conf. 1</b>
Motorconfiguration	CSIR
Power supply (nominal)	220-240V/50Hz
Number of phases	1
Voltage range	198-254V
Approvals	VDE, CCC
Starting torque	HST
Note	Electrical equipment is included and pre-assembled to compressor.

## Applications with KLF4.0CND

	<b>Conf. 1</b>
Refrigerant	R290
Application	LBP+MBP
System cooling	fan 3m/s
Hot gas defrost	OK
Long interval pull down	OK

## Electrical data - Configurations with KLF4.0CND

	<b>Conf. 1</b>
Starting device type	relay
Run capacitor	-/-
Start capacitor	80μF
LRA (locked rotor amps / 4s)	10,2A
RLA (rated load amps / 1s)	1,4A
Cut in current	10,2A

## Model

Designation

**KLF4.0CND**

220-240V/50Hz 1~

Sales code:

**106H2411**

## Compressor dimensions

Housing	A Height	182mm / 7,17in
	B Height	175mm / 6,89in
	C Length shell	198mm / 7,8in
	D Length w. cover	238mm / 9,37in
	E Width	160mm / 6,3in

Connectors		Suction	Discharge	Process
		X	Y	Z
Diameter	[mm]	øi 8,11-8,29	øi 6,11-6,29	øi 6,11-6,29
	(i:inside, o:outside) [in]	øi 0,32-0,33	øi 0,24-0,25	øi 0,24-0,25
Material		copper	copper	copper
Horizontal angle	±2°	35°	13°	0°
Vertical angle	±2°	30°	40°	145°
Position l/h/w	[mm]	120/72/57	112/106/81	-97/94/72
	[in]	4,7/2,8/2,2	4,4/4,2/3,2	-3,8/3,7/2,8
Straight tube l.	[mm]	14	14	14
	[in]	0,5	0,5	0,5

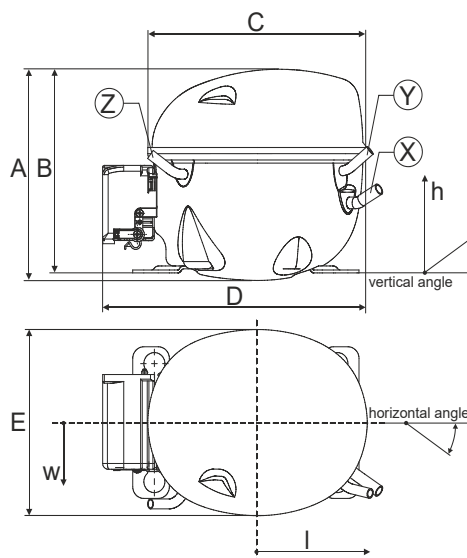

## Compressor fixation

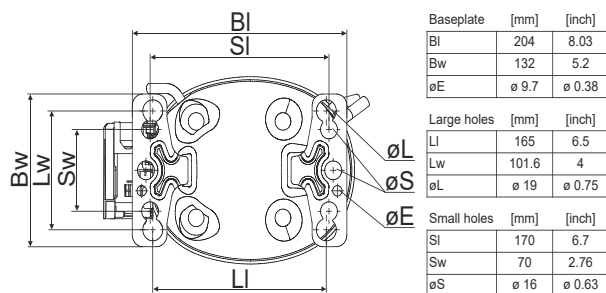

### Bolt joint



### Snap-on

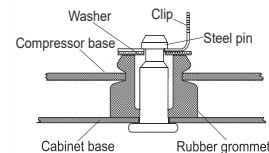

## Mounting accessories

	one comp.	multi pack
Bolt joint   M6   ø16mm	118-1917	118-1918
Bolt joint   ø1/4"   ø16mm	118-1946	
Bolt joint   ø1/4"   ø19mm	118-1949	
Snap-on   ø7,3   ø16mm	118-1947	118-1919

## Application notes

Provision for PE Grounding is located at the PE Stamp on the compressor

## Model

Designation	<b>KLF4.0CND</b>	<b>220-240V/50Hz</b>	Conf. 1	Sales code:	<b>106H2411</b>
-------------	------------------	----------------------	---------	-------------	-----------------

## Configuration

Motorconfiguration	CSIR
Power supply (nominal)	220-240V/50Hz 1~
Refrigerant	R290
Application	LBP+MBP
Voltage range	198-254V
Starting torque	HST
Approvals	VDE
	CCC

## Electrical accessories / wiring diagram

CSIR

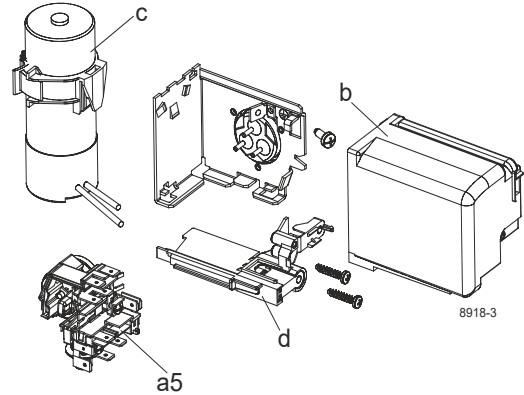

## Ambient/ machine room temperatures minimum /maximum

Ambient temperature range: 10 - 43°C / 50 - 110°F

Machine room temperature range: 10 - 48°C / 50 - 119°F

Compressor cooling: fan 3m/s

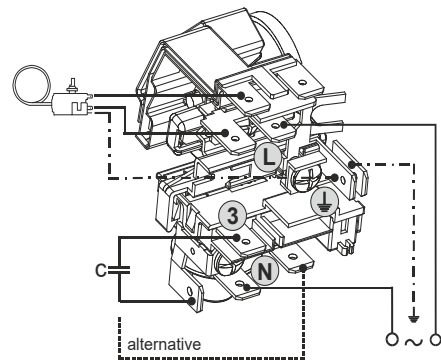

## Operation pressure range

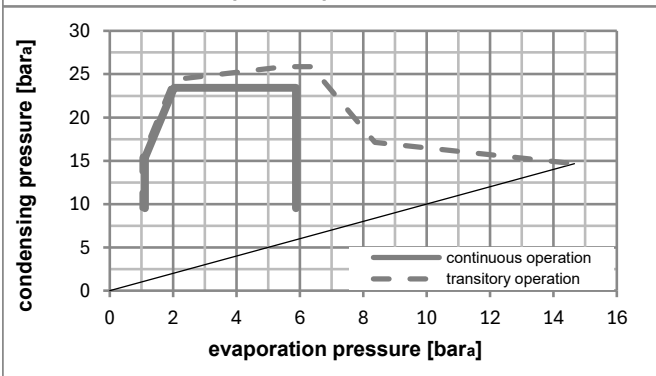
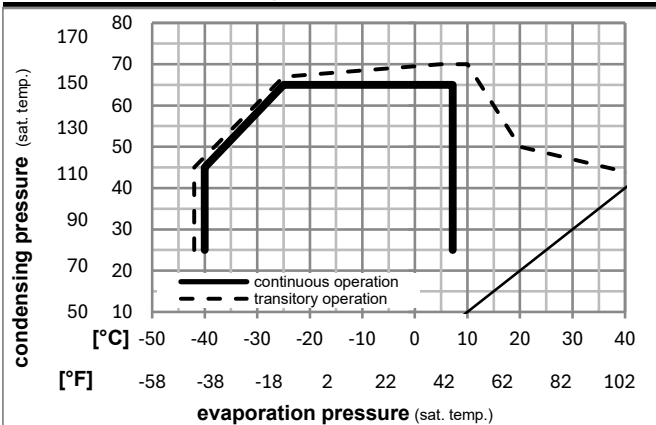

## Components (already pre-assembled)

a5	current relay (T1189/L6-S3)	117U7073
c	start capacitor (80µF, 6.3mm)	117U5001
b	cover terminal board	10636401
.	screw uni en iso 4757	10641201

## Alternative comp. (already pre-assembled)

.	cable clamp (screws not included)	16058100
.	screw - uni6954	10636000
.	screw - uni6954	10636200

## Model

Designation **KLF4.0CND** **220-240V/50Hz** Conf. 1 Sales code: **106H2411**

## Optimization + standard conditions

R290, 220V/50Hz, CSIR, fan 3m/s, VDE, CCC

	Evaporating pressure (saturation temperature)				Cooling capacity			COP	EER	P1	Power consumption		ASHRAE LBP	
	pe	pc	RGT	Tliq	[W]	[Btu/h]	[kcal/h]				I	m		
	[°C]	[°F]	[°C]	[°F]	[W]	[Btu/h]	[kcal/h]	[W/W]	[Btu/Wh]	[kcal/Wh]	[W]	[A]	[kg/h]	
	-23	54	32	32	182,9	625	157,4	1,48	5,04	1,27	123,9	0,99	1,85	ASHRAE LBP
	-10	130	90	90										
	-25	55	32	55	135,8	464	116,9	1,13	3,85	0,97	120,6	0,99	1,69	cecomaf LBP
	-13	131	90	131										
	-35	40	20	40	100,2	342	86,2	1,14	3,88	0,98	88,1	0,91	1,14	EN12900 LBP
	-31	104	68	104										
	-7	54	35	46	335,7	1146	288,9	2,08	7,10	1,79	161,5	1,10	3,83	ASHRAE MBP
	20	130	95	115										
	-10	55	32	55	265,2	906	228,2	1,71	5,85	1,47	154,7	1,08	3,35	cecomaf MBP
	14	131	90	131										
	-10	45	20	45	299,1	1021	257,4	2,14	7,31	1,84	139,7	1,03	3,67	EN12900 MBP
	14	113	68	113										

## Performance tables

R290, 220V/50Hz, CSIR, fan 3m/s, VDE, CCC

	pe		Cooling capacity			COP			EER			P1	I	m
	[°C]	[°F]	[W]	[Btu/h]	[kcal/h]	[W/W]	[Btu/Wh]	[kcal/Wh]	[W]	[A]	[kg/h]			
[°C / °F]	-40	-40	67,2	229	57,8	0,80	2,72	0,69	84,2	0,91	0,75			
cond. pressure	-35	-31	95,4	326	82,1	1,03	3,52	0,89	92,4	0,92	1,07			
pc= 45/113	-25	-13	163,7	559	140,9	1,48	5,04	1,27	111,0	0,96	1,85			
return gas temp.	-15	5	254,8	870	219,3	1,95	6,67	1,68	130,4	1,01	2,90			
RGT= 32/90	-5	23	376,5	1286	324,0	2,54	8,67	2,18	148,4	1,06	4,33			
liquid temp	0	32	451,3	1541	388,4	2,89	9,88	2,49	156,0	1,08	5,24			
Tliq= 45/113	7,2	45	578,1	1974	497,5	3,51	11,99	3,02	164,7	1,11	6,79			
[°C / °F]	-40	-40	48,1	164	41,4	0,52	1,78	0,45	92,3	0,92	0,59			
cond. pressure	-35	-31	74,4	254	64,0	0,74	2,52	0,64	100,6	0,94	0,92			
pc= 55/131	-25	-13	135,8	464	116,9	1,13	3,85	0,97	120,6	0,99	1,69			
return gas temp	-15	5	215,8	737	185,7	1,51	5,15	1,30	143,2	1,05	2,71			
RGT= 32/90	-5	23	322,2	1100	277,3	1,94	6,63	1,67	166,0	1,11	4,10			
liquid temp	0	32	387,8	1324	333,8	2,19	7,49	1,89	176,8	1,15	4,98			
Tliq= 55/131	7,2	45	499,5	1706	429,9	2,62	8,95	2,25	190,7	1,20	6,51			