

Model

Designation	KLF4.0CND	220-240V/50Hz 1~	Sales code:	106H2411
-------------	------------------	------------------	-------------	-----------------

Compressor design

Oil type	Polyolester	Refrigerant(s)	R290
Oil viscosity	9,7cST	Displacement	4cm ³ / 0,24cu.in
Oil quantity	170cm ³ / 5,7fl.oz	Compressors on pallet	100
Refr. charge - tech. limit	200g / 7,1oz		
Free gas volume comp.	1630cm ³ / 55,1fl.oz		
Weight	8,95kg / 19,7lbs		
Motor protection	external		
Winding resistance main	13,1Ω (at 25°C)		
Winding resistance aux	25,3Ω (at 25°C)		
Max. winding temp.	125°C / 257°F		
Max. discharge temp.	130°C / 266°F		



General - Configurations with KLF4.0CND

	Conf. 1
Motorconfiguration	CSIR
Power supply (nominal)	220-240V/50Hz
Number of phases	1
Voltage range	198-254V
Approvals	VDE, CCC
Starting torque	HST
Note	Electrical equipment is included and pre-assembled to compressor.

Applications with KLF4.0CND

	Conf. 1
Refrigerant	R290
Application	LBP+MBP
System cooling	fan 3m/s
Hot gas defrost	OK
Long interval pull down	OK

Electrical data - Configurations with KLF4.0CND

	Conf. 1
Starting device type	relay
Run capacitor	-/-
Start capacitor	80μF
LRA (locked rotor amps / 4s/ U(N))	10,2A
RLA (rated load amps / 1s/ U(N))	1,4A
Cut in current (U(N))	10,2A

Model

Designation	KLF4.0CND	220-240V/50Hz 1~	Sales code:	106H2411
-------------	------------------	------------------	-------------	-----------------

Compressor dimensions

Housing	A Height	182mm / 7,17in
	B Height	175mm / 6,89in
	C Length shell	198mm / 7,8in
	D Length w. cover	238mm / 9,37in
	E Width	160mm / 6,3in

Connectors		Suction	Discharge	Process
		X	Y	Z
Diameter	[mm]	øi 8,11-8,29	øi 6,11-6,29	øi 6,11-6,29
	(i:inside, o:outside) [in]	øi 0,32-0,33	øi 0,24-0,25	øi 0,24-0,25
Material		copper	copper	copper
Horizontal angle	±2°	35°	13°	0°
Vertical angle	±2°	30°	40°	145°
Position l/h/w	[mm]	120/72/57	112/106/81	-97/94/72
	[in]	4,7/2,8/2,2	4,4/4,2/3,2	-3,8/3,7/2,8
Straight tube l.	[mm]	14	14	14
	[in]	0,5	0,5	0,5

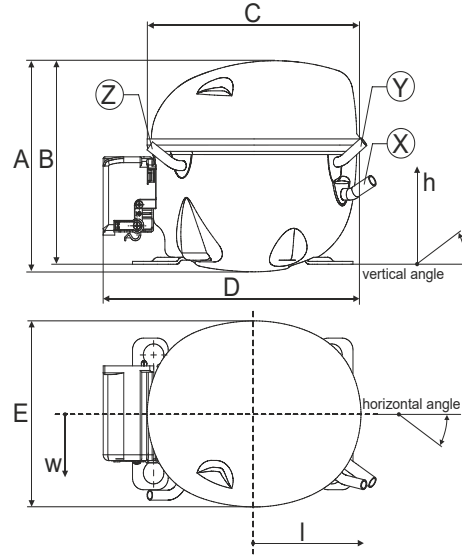

Compressor fixation

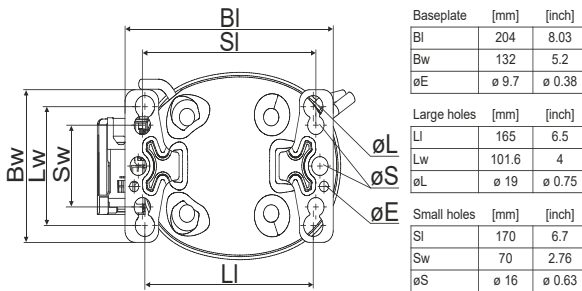

Bolt joint

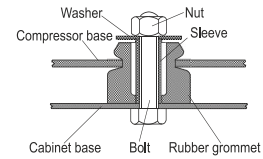

Snap-on

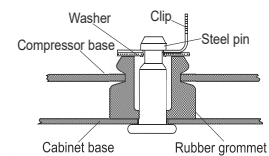

Mounting accessories	one comp.	multi pack
Bolt joint M6 ø16mm	118-1917	118-1918
Bolt joint ø1/4" ø16mm	118-1946	
Bolt joint ø1/4" ø19mm	118-1949	
Snap-on ø7,3 ø16mm	118-1947	118-1919

Application notes

Provision for PE Grounding is located at the PE Stamp on the compressor

Model

Designation	KLF4.0CND	220-240V/50Hz	Conf. 1	Sales code:	106H2411
-------------	------------------	----------------------	---------	-------------	-----------------

Configuration

Motorconfiguration	CSIR
Power supply (nominal)	220-240V/50Hz 1~
Refrigerant	R290
Application	LBP+MBP
Voltage range	198-254V
Starting torque	HST
Approvals	VDE CCC

Electrical accessories / wiring diagram

CSIR

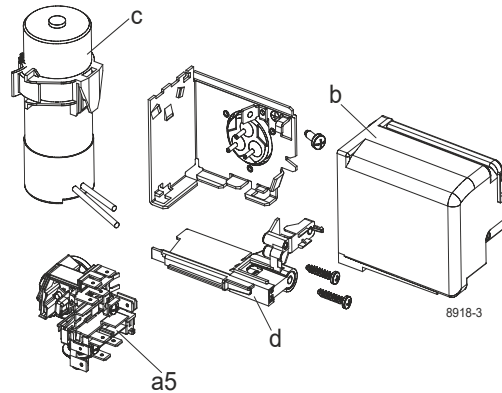

Ambient/ machine room temperatures minimum /maximum

Ambient temperature range:	10 - 43°C / 50 - 110°F
Machine room temperature range:	10 - 48°C / 50 - 119°F
Compressor cooling:	fan 3m/s

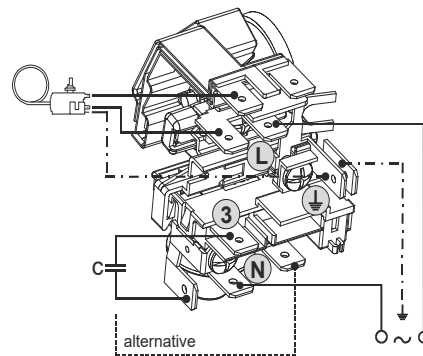

Operation pressure range

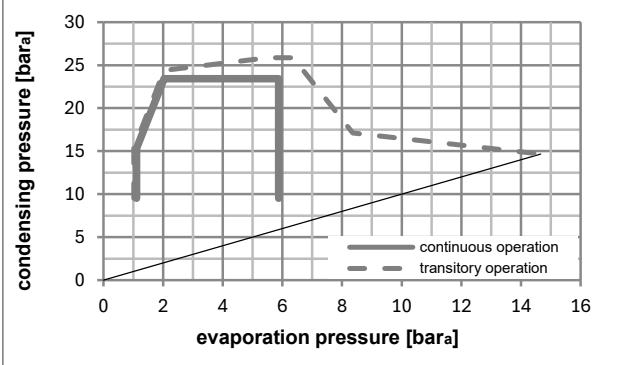
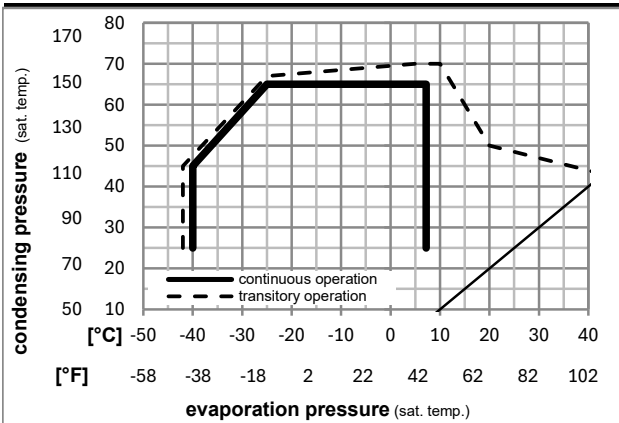

Components (already pre-assembled)

a5	current relay (T1189/L6-S3)	117U7073
c	start capacitor (80µF, 6.3mm)	117U5001
b	cover terminal board	10636401
.	screw uni en iso 4757	10641201

Alternative comp. (already pre-assembled)

.	cable clamp (screws not included)	16058100
.	screw - uni6954	10636000
.	screw - uni6954	10636200

Model

Designation **KLF4.0CND** **220-240V/50Hz** Conf. 1 Sales code: **106H2411**

Optimization + standard conditions

R290, 220V/50Hz, CSIR, fan 3m/s, VDE, CCC

Evaporating pressure (saturation temperature)				Condensing pressure (saturation temperature)			Power consumption				Current consumption		Ref. mass flow ṁ	
pe	pc	RGT	Tliq	Cooling capacity	COP	EER	P1	I						
[°C]	[°C]	[°C]	[°C]	[W]	[Btu/h]	[kcal/h]	[W/W]	[Btu/Wh]	[kcal/Wh]	[W]	[A]	[kg/h]		
[°C]	-23	54	32	32	182,9	625	157,4	1,48	5,04	1,27	123,9	0,99	1,85	ASHRAE LBP
[°F]	-10	130	90	90										
[°C]	-25	55	32	55	135,8	464	116,9	1,13	3,85	0,97	120,6	0,99	1,69	cecomaf LBP
[°F]	-13	131	90	131										
[°C]	-35	40	20	40	100,2	342	86,2	1,14	3,88	0,98	88,1	0,91	1,14	EN12900 LBP
[°F]	-31	104	68	104										
[°C]	-7	54	35	46	335,7	1146	288,9	2,08	7,10	1,79	161,5	1,10	3,83	ASHRAE MBP
[°F]	20	130	95	115										
[°C]	-10	55	32	55	265,2	906	228,2	1,71	5,85	1,47	154,7	1,08	3,35	cecomaf MBP
[°F]	14	131	90	131										
[°C]	-10	45	20	45	299,1	1021	257,4	2,14	7,31	1,84	139,7	1,03	3,67	EN12900 MBP
[°F]	14	113	68	113										

Performance tables

R290, 220V/50Hz, CSIR, fan 3m/s, VDE, CCC

	pe		Cooling capacity			COP	EER	P1	I	m	
	[°C]	[°F]	[W]	[Btu/h]	[kcal/h]	[W/W]	[Btu/Wh]	[kcal/Wh]	[W]	[A]	[kg/h]
[°C / °F]	-40	-40	67,2	229	57,8	0,80	2,72	0,69	84,2	0,91	0,75
cond. pressure	-35	-31	95,4	326	82,1	1,03	3,52	0,89	92,4	0,92	1,07
pc= 45/113	-25	-13	163,7	559	140,9	1,48	5,04	1,27	111,0	0,96	1,85
return gas temp.	-15	5	254,8	870	219,3	1,95	6,67	1,68	130,4	1,01	2,90
RGT= 32/90	-5	23	376,5	1286	324,0	2,54	8,67	2,18	148,4	1,06	4,33
liquid temp	0	32	451,3	1541	388,4	2,89	9,88	2,49	156,0	1,08	5,24
Tliq= 45/113	7,2	45	578,1	1974	497,5	3,51	11,99	3,02	164,7	1,11	6,79
[°C / °F]	-40	-40	48,1	164	41,4	0,52	1,78	0,45	92,3	0,92	0,59
cond. pressure	-35	-31	74,4	254	64,0	0,74	2,52	0,64	100,6	0,94	0,92
pc= 55/131	-25	-13	135,8	464	116,9	1,13	3,85	0,97	120,6	0,99	1,69
return gas temp.	-15	5	215,8	737	185,7	1,51	5,15	1,30	143,2	1,05	2,71
RGT= 32/90	-5	23	322,2	1100	277,3	1,94	6,63	1,67	166,0	1,11	4,10
liquid temp	0	32	387,8	1324	333,8	2,19	7,49	1,89	176,8	1,15	4,98
Tliq= 55/131	7,2	45	499,5	1706	429,9	2,62	8,95	2,25	190,7	1,20	6,51