

## Model

Designation	<b>KLF4.0CNDS</b>	220-240V/50Hz 1~	Sales code:	<b>106H2403</b>
-------------	-------------------	------------------	-------------	-----------------

## Compressor design

Oil type	Polyolester	Refrigerant(s)	<b>R290</b>
Oil viscosity	9,7cST	Displacement	4cm <sup>3</sup> / 0,24cu.in
Oil quantity	170cm <sup>3</sup> / 5,7fl.oz	Compressors on pallet	100
Refr. charge - tech. limit	200g / 7,1oz		
Free gas volume comp.	1630cm <sup>3</sup> / 55,1fl.oz		
Weight	8,95kg / 19,7lbs		
Motor protection	external		
Winding resistance main	13,1Ω (at 25°C)		
Winding resistance aux	25,3Ω (at 25°C)		
Max. winding temp.	125°C / 257°F		
Max. discharge temp.	130°C / 266°F		
Additional note	Very good robustness against liquid intake. Ice-cube maker optimization - indirect suction intake.		



## General - Configurations with KLF4.0CNDS

	<b>Conf. 1</b>
Motorconfiguration	CSIR
Power supply (nominal)	220-240V/50Hz
Number of phases	1
Voltage range	198-254V
Approvals	VDE, CCC
Starting torque	HST
Note	- / -

## Applications with KLF4.0CNDS

	<b>Conf. 1</b>
Refrigerant	R290
Application	LBP+MBP
System cooling	fan 3m/s
Hot gas defrost	OK
Long interval pull down	OK

## Electrical data - Configurations with KLF4.0CNDS

	<b>Conf. 1</b>
Starting device type	relay
Run capacitor	-/-
Start capacitor	80μF
LRA (locked rotor amps / 4s)	10,2A
RLA (rated load amps / 1s)	1,4A
Cut in current	10,2A

## Model

Designation

**KLF4.0CNDS**

220-240V/50Hz 1~

Sales code:

**106H2403**

## Compressor dimensions

Housing	A Height	182mm / 7,17in
	B Height	175mm / 6,89in
	C Length shell	198mm / 7,8in
	D Length w. cover	238mm / 9,37in
	E Width	160mm / 6,3in

Connectors		Suction	Discharge	Process
		X	Y	Z
Diameter	[mm]	øi 8,11-8,29	øi 6,11-6,29	øi 6,11-6,29
(i:inside, o:outside)	[in]	øi 0,32-0,33	øi 0,24-0,25	øi 0,24-0,25
Material		copper	copper	copper
Horizontal angle	±2°	35°	13°	0°
Vertical angle	±2°	30°	40°	145°
Position l/h/w	[mm]	120/72/57	112/106/81	-97/94/72
	[in]	4,7/2,8/2,2	4,4/4,2/3,2	-3,8/3,7/2,8
Straight tube l.	[mm]	14	14	14
	[in]	0,5	0,5	0,5

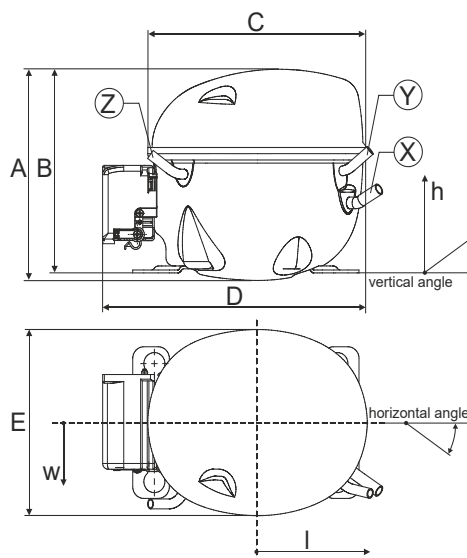

## Compressor fixation

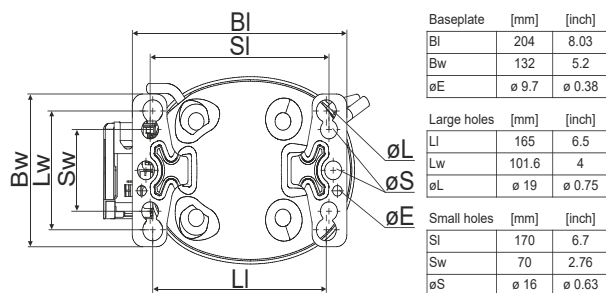

### Bolt joint

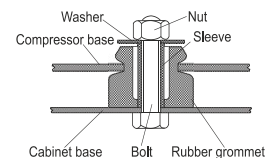

### Snap-on

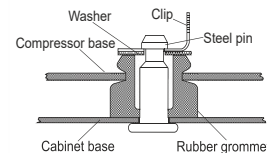

## Mounting accessories

	one comp.	multi pack
Bolt joint   M6   ø16mm	118-1917	118-1918
Bolt joint   ø1/4"   ø16mm	118-1946	
Bolt joint   ø1/4"   ø19mm	118-1949	
Snap-on   ø7,3   ø16mm	118-1947	118-1919

## Application notes

Provision for PE Grounding is located at the PE Stamp on the compressor

### Model

Designation	<b>KLF4.0CND5</b>	<b>220-240V/50Hz</b>	Conf. 1	Sales code:	<b>106H2403</b>
-------------	-------------------	----------------------	---------	-------------	-----------------

### Configuration

Motorconfiguration	CSIR
Power supply (nominal)	220-240V/50Hz 1~
Refrigerant	R290
Application	LBP+MBP
Voltage range	198-254V
Starting torque	HST
Approvals	VDE
	CCC

### Electrical accessories / wiring diagram

CSIR

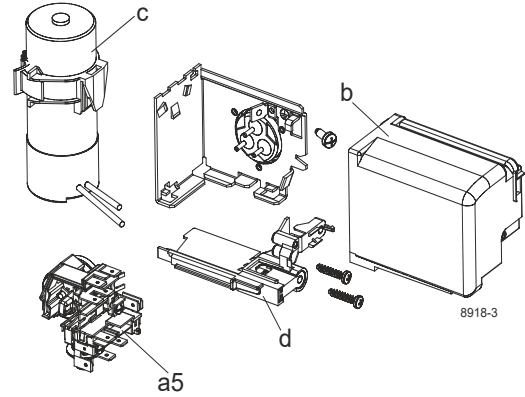

### Ambient/ machine room temperatures minimum /maximum

Ambient temperature range: 10 - 43°C / 50 - 110°F

Machine room temperature range: 10 - 48°C / 50 - 119°F

Compressor cooling: fan 3m/s

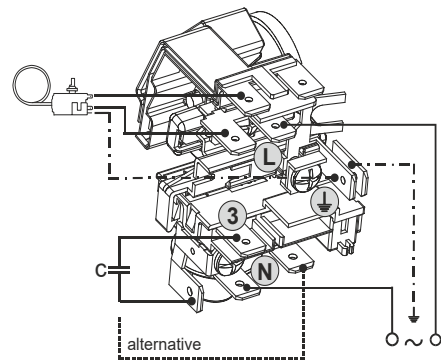

### Operation pressure range

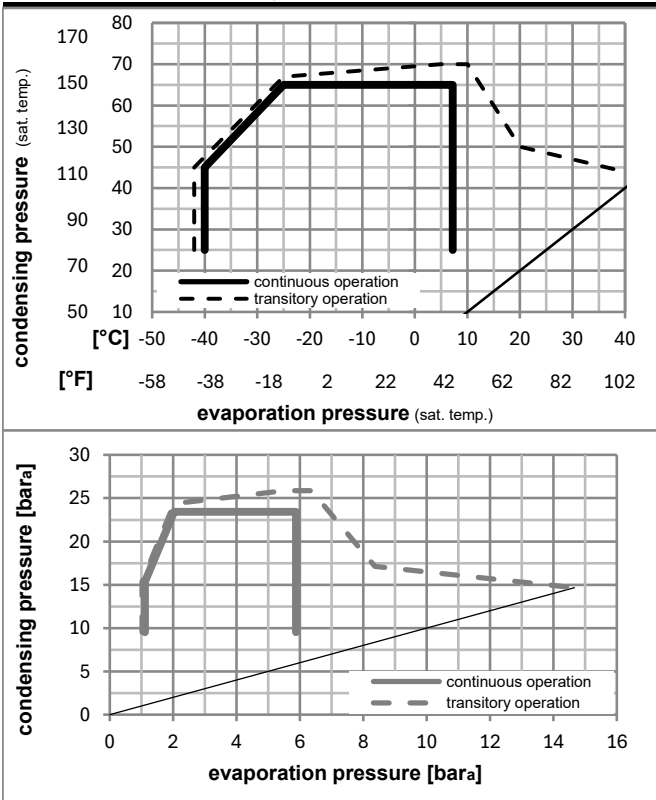

### Components

a5	current relay (T1189/L6-S3)	117U7073
c	start capacitor (80µF, 6.3mm)	117U5001
b, d	cover + clamp + screws(5VA) in bag	103N1060

### Alternative components

b, d	cover + clamp + screws(5VA-compl.)	103N0600
------	------------------------------------	----------

## Model

Designation	<b>KLF4.0CNDS</b>	<b>220-240V/50Hz</b>	<b>Conf. 1</b>	Sales code:	<b>106H2403</b>
-------------	-------------------	----------------------	----------------	-------------	-----------------

## Optimization + standard conditions

R290, 220V/50Hz, CSIR, fan 3m/s, VDE, CCC

	Evaporating pressure (saturation temperature)				Cooling capacity			COP	EER	P1	Power consumption		ASHRAE LBP	
	pe	pc	RGT	Tliq	[W]	[Btu/h]	[kcal/h]				I	m		
	[°C]	[°F]	[°C]	[°F]	[W]	[Btu/h]	[kcal/h]	[W/W]	[Btu/Wh]	[kcal/Wh]	[W]	[A]	[kg/h]	
	-23	54	32	32	176,4	602	151,8	1,44	4,92	1,24	122,5	0,98	1,79	ASHRAE LBP
	-10	130	90	90										
	-25	55	32	55	131,0	447	112,8	1,10	3,75	0,95	119,3	0,98	1,63	cecomaf LBP
	-13	131	90	131										
	-35	40	20	40	96,7	330	83,2	1,11	3,79	0,95	87,1	0,90	1,10	EN12900 LBP
	-31	104	68	104										
	-7	54	35	46	323,8	1106	278,7	2,03	6,92	1,74	159,7	1,09	3,69	ASHRAE MBP
	20	130	95	115										
	-10	55	32	55	255,8	874	220,1	1,67	5,71	1,44	153,0	1,07	3,24	cecomaf MBP
	14	131	90	131										
	-10	45	20	45	288,5	985	248,3	2,09	7,13	1,80	138,2	1,02	3,54	EN12900 MBP
	14	113	68	113										

## Performance tables

R290, 220V/50Hz, CSIR, fan 3m/s, VDE, CCC

	pe		Cooling capacity			COP	EER		P1	I	m
	[°C]	[°F]	[W]	[Btu/h]	[kcal/h]		[Btu/Wh]	[kcal/Wh]			
[°C / °F]	-40	-40	64,8	221	55,8	0,78	2,66	0,67	83,3	0,90	0,72
cond. pressure	-35	-31	92,0	314	79,2	1,01	3,44	0,87	91,4	0,91	1,03
pc= 45/113	-25	-13	158,0	539	135,9	1,44	4,92	1,24	109,7	0,95	1,78
return gas temp.	-15	5	245,8	840	211,6	1,91	6,51	1,64	129,0	1,00	2,80
RGT= 32/90	-5	23	363,2	1240	312,6	2,48	8,46	2,13	146,7	1,05	4,18
liquid temp	0	32	435,4	1487	374,7	2,82	9,64	2,43	154,2	1,07	5,05
Tliq= 45/113	7,2	45	557,7	1905	479,9	3,42	11,70	2,95	162,8	1,10	6,55
[°C / °F]	-40	-40	46,4	159	39,9	0,51	1,74	0,44	91,3	0,91	0,57
cond. pressure	-35	-31	71,8	245	61,8	0,72	2,46	0,62	99,5	0,93	0,89
pc= 55/131	-25	-13	131,0	447	112,8	1,10	3,75	0,95	119,3	0,98	1,63
return gas temp	-15	5	208,1	711	179,1	1,47	5,02	1,27	141,6	1,03	2,62
RGT= 32/90	-5	23	310,8	1061	267,5	1,89	6,47	1,63	164,2	1,10	3,96
liquid temp	0	32	374,1	1278	322,0	2,14	7,31	1,84	174,8	1,14	4,81
Tliq= 55/131	7,2	45	481,9	1646	414,7	2,56	8,73	2,20	188,5	1,18	6,28