

Model

Designation	KLF4.0CNH	115-127V/60Hz 1~	Sales code:	106H3401
-------------	------------------	------------------	-------------	-----------------

Compressor design

Oil type	Polyolester	Refrigerant(s)	R290
Oil viscosity	9,7cST	Displacement	4cm ³ / 0,24cu.in
Oil quantity	170cm ³ / 5,7fl.oz	Compressors on pallet	100
Refr. charge - tech. limit	200g / 7,1oz		
Free gas volume comp.	1630cm ³ / 55,1fl.oz		
Weight	8,3kg / 18,3lbs		
Motor protection	external		
Winding resistance main	3,4Ω (at 25°C)		
Winding resistance aux	8Ω (at 25°C)		
Max. winding temp.	125°C / 257°F		
Max. discharge temp.	130°C / 266°F		



General - Configurations with KLF4.0CNH

	Conf. 1	Conf. 2
Motorconfiguration	CSIR	RSCR
Power supply (nominal)	115-127V/60Hz	115-127V/60Hz
Number of phases	1	1
Voltage range	95-140V	95-140V
Approvals	UL, CCC	UL, CCC
Starting torque	HST	LST
Note	LRA value on compressor label and datasheet may differ due to different test conditions for UL approval.	

Applications with KLF4.0CNH

	Conf. 1	Conf. 2
Refrigerant	R290	R290
Application	LBP+MBP	LBP+MBP
System cooling	fan 3m/s	fan 3m/s
Hot gas defrost	OK	OK
Long interval pull down	OK	OK

Electrical data - Configurations with KLF4.0CNH

	Conf. 1	Conf. 2
Starting device type	relay	PTC
Run capacitor	-/-	15μF
Start capacitor	240μF	-/-
LRA (locked rotor amps / 4s)	20,5A	15,6A
RLA (rated load amps / 1s)	2,7A	2,7A
Cut in current	20,5A	23,1A

Model

Designation

KLF4.0CNH

115-127V/60Hz 1~

Sales code:

106H3401

Compressor dimensions

Housing	A Height	182mm / 7,17in
	B Height	175mm / 6,89in
	C Length shell	198mm / 7,8in
	D Length w. cover	238mm / 9,37in
	E Width	160mm / 6,3in

Connectors		Suction	Discharge	Process
		X	Y	Z
Diameter	[mm]	øi 8,11-8,29	øi 6,41-6,59	øi 6,41-6,59
	(i:inside, o:outside) [in]	øi 0,32-0,33	øi 0,25-0,26	øi 0,25-0,26
Material		copper	copper	copper
Horizontal angle	±2°	35°	13°	0°
Vertical angle	±2°	30°	40°	145°
Position l/h/w	[mm]	120/72/57	112/106/81	-97/94/72
	[in]	4,7/2,8/2,2	4,4/4,2/3,2	-3,8/3,7/2,8
Straight tube l.	[mm]	14	14	14
	[in]	0,5	0,5	0,5

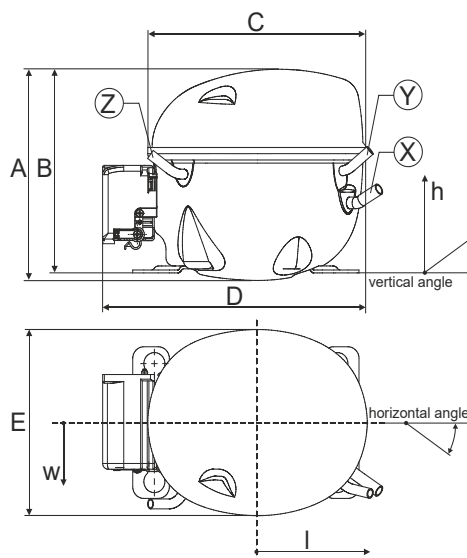

Compressor fixation

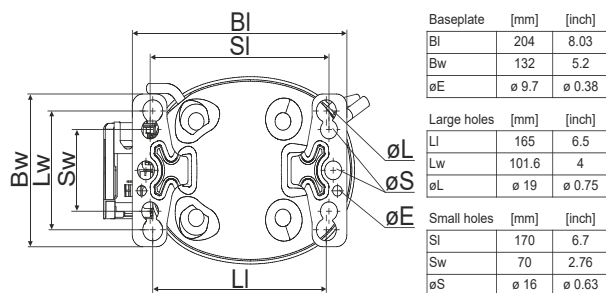

Bolt joint

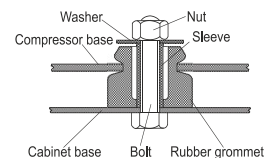

Snap-on

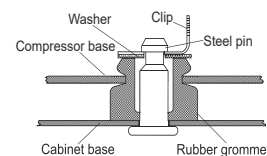

Mounting accessories

	one comp.	multi pack
Bolt joint M6 ø16mm	118-1917	118-1918
Bolt joint ø1/4" ø16mm	118-1946	
Bolt joint ø1/4" ø19mm	118-1949	
Snap-on ø7,3 ø16mm	118-1947	118-1919

Application notes

Provision for PE Grounding is located at the PE Stamp on the compressor

Model

Designation	KLF4.0CNH	115-127V/60Hz	Conf. 1	Sales code:	106H3401
-------------	------------------	----------------------	---------	-------------	-----------------

Configuration

Motorconfiguration	CSIR
Power supply (nominal)	115-127V/60Hz 1~
Refrigerant	R290
Application	LBP+MBP
Voltage range	95-140V
Starting torque	HST
Approvals	UL
	CCC

Electrical accessories / wiring diagram

CSIR

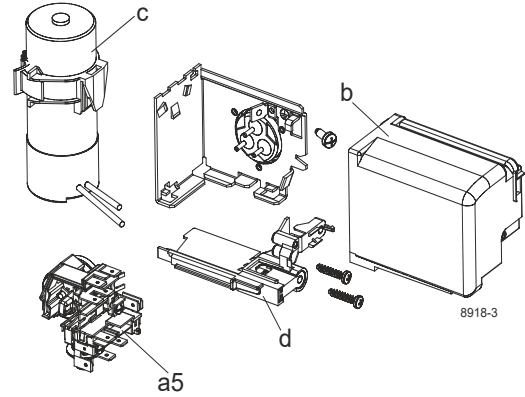

Ambient/ machine room temperatures minimum /maximum

Ambient temperature range: 10 - 43°C / 50 - 110°F

Machine room temperature range: 10 - 48°C / 50 - 119°F

Compressor cooling: fan 3m/s

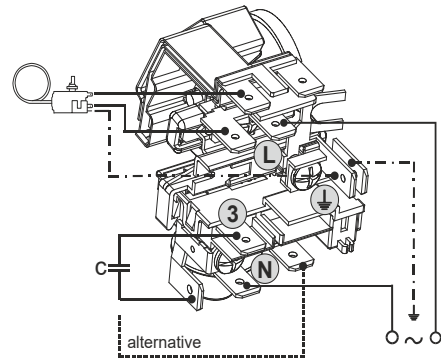

Operation pressure range

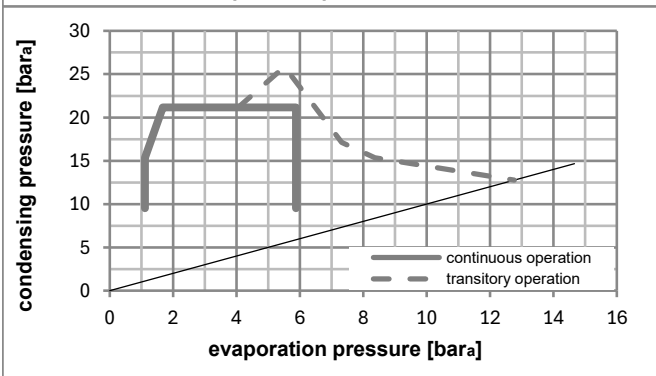
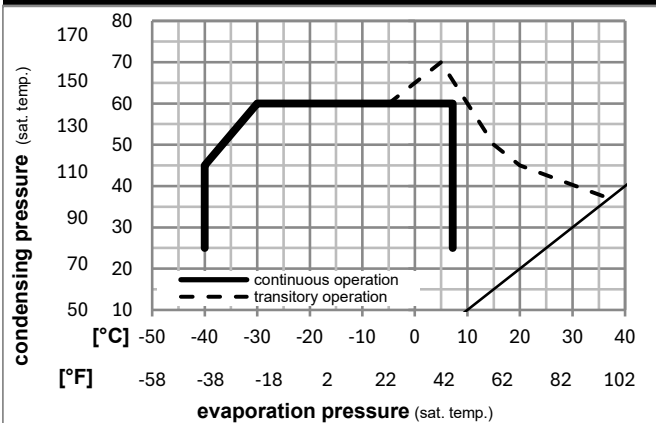

Components

a5	current relay (T1209/L6-S4)	117U7074
c	start capacitor (240µF)	117U5002
b, d	cover + clamp + screws(5VA) in bag	103N1060

Alternative components

b, d	cover + clamp + screws(5VA-compl.)	103N0600
------	------------------------------------	----------

Model

Designation **KLF4.0CNH** **115-127V/60Hz** Conf. 1 Sales code: **106H3401**

Optimization + standard conditions

R290, 115V/60Hz, CSIR, fan 3m/s, UL, CCC

	Evaporating pressure (saturation temperature)				Cooling capacity			COP	EER	P1	Power consumption		ASHRAE LBP	
	pe	pc	RGT	Tliq	[W]	[Btu/h]	[kcal/h]				I	m		
	[°C]	[°F]	[°C]	[°F]	[W]	[Btu/h]	[kcal/h]	[W/W]	[Btu/Wh]	[kcal/Wh]	[W]	[A]	[kg/h]	
	-23	54	32	32	228,0	779	196,2	1,49	5,08	1,28	153,2	1,92	2,31	ASHRAE LBP
	-10	130	90	90										
	-25	55	32	55	169,4	579	145,8	1,14	3,89	0,98	148,7	1,89	2,11	cecomaf LBP
	-13	131	90	131										
	-35	40	20	40	127,2	434	109,5	1,05	3,58	0,90	121,3	1,73	1,45	EN12900 LBP
	-31	104	68	104										
	-7	54	35	46	418,6	1429	360,2	2,09	7,14	1,80	200,3	2,25	4,77	ASHRAE MBP
	20	130	95	115										
	-10	55	32	55	331,7	1133	285,5	1,72	5,88	1,48	192,8	2,20	4,20	cecomaf MBP
	14	131	90	131										
	-10	45	20	45	376,1	1284	323,7	2,14	7,30	1,84	175,9	2,07	4,62	EN12900 MBP
	14	113	68	113										

Performance tables

R290, 115V/60Hz, CSIR, fan 3m/s, UL, CCC

	pe		Cooling capacity			COP	EER		P1	I	m
	[°C]	[°F]	[W]	[Btu/h]	[kcal/h]		[Btu/Wh]	[kcal/Wh]			
[°C / °F]	-40	-40	81,8	279	70,4	0,71	2,43	0,61	115,1	1,71	0,91
cond. pressure	-34	-30	122,7	419	105,6	0,99	3,39	0,86	123,5	1,75	1,38
pc= 45/113	-23	-10	222,9	761	191,8	1,52	5,20	1,31	146,3	1,88	2,52
return gas temp.	-15	5	320,7	1095	276,0	1,94	6,63	1,67	165,2	2,00	3,65
RGT= 32/90	-4	25	492,6	1682	423,9	2,63	8,98	2,26	187,3	2,15	5,68
liquid temp	0	32	566,1	1933	487,2	2,93	10,02	2,52	193,0	2,20	6,57
Tliq= 45/113	7,2	45	724,3	2473	623,3	3,63	12,41	3,13	199,4	2,24	8,51
[°C / °F]	-40	-40	53,0	181	45,6	0,48	1,65	0,42	109,9	1,67	0,65
cond. pressure	-34	-30	92,9	317	80,0	0,76	2,59	0,65	122,6	1,74	1,15
pc= 55/131	-23	-10	184,6	630	158,9	1,20	4,10	1,03	153,7	1,93	2,30
return gas temp	-15	5	270,4	924	232,7	1,51	5,17	1,30	178,6	2,09	3,40
RGT= 32/90	-4	25	418,8	1430	360,4	2,01	6,87	1,73	208,3	2,31	5,34
liquid temp	0	32	482,1	1646	414,9	2,23	7,60	1,92	216,6	2,37	6,19
Tliq= 55/131	7,2	45	618,4	2112	532,2	2,72	9,27	2,34	227,7	2,46	8,06

Model

Designation	KLF4.0CNH	115-127V/60Hz	Conf. 2	Sales code:	106H3401
-------------	------------------	----------------------	----------------	-------------	-----------------

Configuration

Motorconfiguration	RSCR
Power supply (nominal)	115-127V/60Hz 1~
Refrigerant	R290
Application	LBP+MBP
Voltage range	95-140V
Starting torque	LST
Approvals	UL CCC

Electrical accessories / wiring diagram

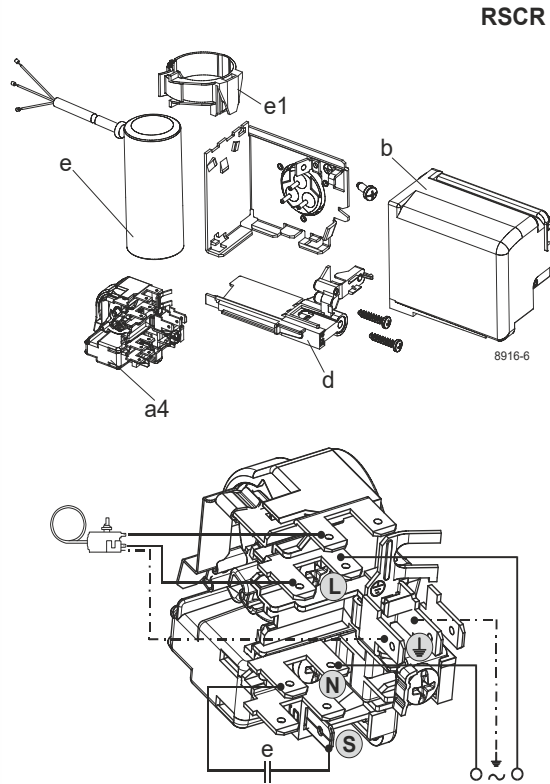

Ambient/ machine room temperatures minimum /maximum

Ambient temperature range:	10 - 43°C / 50 - 110°F
Machine room temperature range:	10 - 48°C / 50 - 119°F
Compressor cooling:	fan 3m/s

Operation pressure range

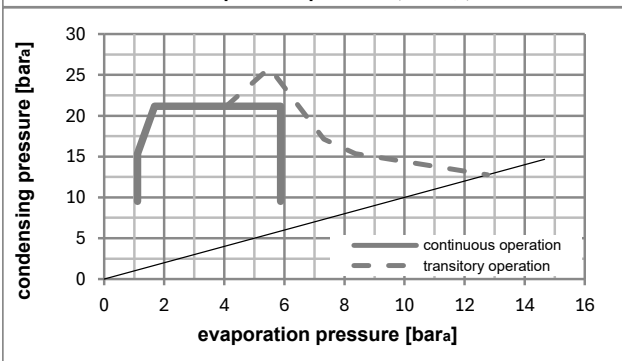
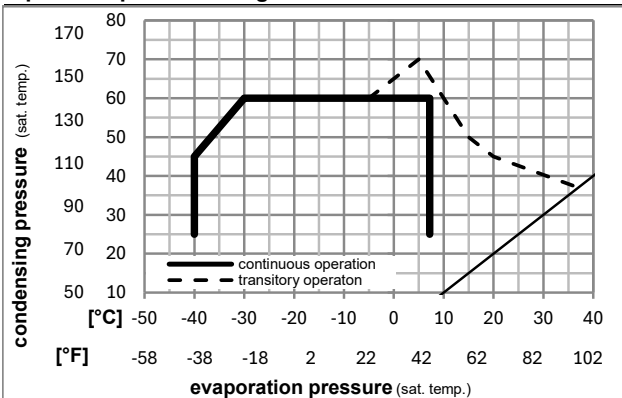

Components

a4	DLS4 (PTC,6.3mm, T1209/L6 - S4)	103N0210
e	run capacitor (15μF, 6,3mm)	117-7153
b, d	cover + clamp + screws(5VA) in bag	103N1060
e1	retaining clamp	103N0535

Alternative components

b, d	cover + clamp + screws(5VA-compl.)	103N0600
------	------------------------------------	----------

Model

Designation	KLF4.0CNH	115-127V/60Hz	Conf. 2	Sales code:	106H3401
-------------	------------------	----------------------	----------------	-------------	-----------------

Optimization + standard conditions

R290, 115V/60Hz, RSCR, fan 3m/s, UL, CCC

	Evaporating pressure (saturation temperature)				Cooling capacity			COP	EER	P1	Power consumption		ASHRAE LBP	
	pe	pc	RGT	Tliq	[W]	[Btu/h]	[kcal/h]				I	m		
	[°C]	[°F]	[°C]	[°C]				[W/W]	[Btu/Wh]	[kcal/Wh]	[W]	[A]	[kg/h]	
	-23	54	32	32	230,4	787	198,3	1,57	5,35	1,35	147,0	1,36	2,33	ASHRAE LBP
	[°F]	-10	130	90										
	-25	55	32	55	171,1	584	147,2	1,20	4,09	1,03	142,8	1,32	2,13	cecomaf LBP
	[°F]	-13	131	90										
	-35	40	20	40	128,1	437	110,2	1,10	3,76	0,95	116,3	1,10	1,46	EN12900 LBP
	[°F]	-31	104	68										
	-7	54	35	46	423,7	1447	364,7	2,22	7,58	1,91	190,8	1,73	4,83	ASHRAE MBP
	[°F]	20	130	95										
	-10	55	32	55	335,8	1147	289,0	1,83	6,24	1,57	183,9	1,67	4,25	cecomaf MBP
	[°F]	14	131	90										
	-10	45	20	45	379,9	1298	327,0	2,26	7,72	1,94	168,1	1,53	4,66	EN12900 MBP
	[°F]	14	113	68										

Performance tables

R290, 115V/60Hz, RSCR, fan 3m/s, UL, CCC

	pe		Cooling capacity			COP	EER	P1	I	m	
	[°C]	[°F]	[W]	[Btu/h]	[kcal/h]						
[°C / °F]	-40	-40	82,7	282	71,2	0,75	2,56	0,65	110,1	1,05	0,92
cond. pressure	-34	-30	123,7	422	106,4	1,04	3,57	0,90	118,3	1,12	1,39
pc= 45/113	-23	-10	224,8	768	193,4	1,60	5,48	1,38	140,1	1,30	2,54
return gas temp.	-15	5	323,9	1106	278,7	2,05	7,00	1,76	158,0	1,45	3,68
RGT= 32/90	-4	25	497,6	1700	428,3	2,78	9,50	2,40	178,8	1,63	5,74
liquid temp	0	32	571,9	1953	492,2	3,10	10,60	2,67	184,2	1,67	6,63
Tliq= 45/113	7,2	45	731,1	2497	629,2	3,84	13,13	3,31	190,2	1,72	8,59
[°C / °F]	-40	-40	53,4	182	46,0	0,51	1,73	0,44	105,6	1,01	0,66
cond. pressure	-34	-30	93,6	320	80,5	0,79	2,71	0,68	118,0	1,11	1,16
pc= 55/131	-23	-10	186,5	637	160,5	1,26	4,32	1,09	147,5	1,36	2,33
return gas temp	-15	5	273,7	935	235,5	1,60	5,47	1,38	170,7	1,56	3,44
RGT= 32/90	-4	25	423,9	1448	364,8	2,14	7,31	1,84	198,1	1,79	5,41
liquid temp	0	32	487,8	1666	419,8	2,37	8,10	2,04	205,6	1,86	6,27
Tliq= 55/131	7,2	45	625,0	2134	537,9	2,90	9,91	2,50	215,3	1,94	8,14