

Model

Designation	KLF4.0CNHS	115-127V/60Hz 1~	Sales code:	106H3403
-------------	-------------------	------------------	-------------	-----------------

Compressor design

Oil type	Polyolester	Refrigerant(s)	R290
Oil viscosity	9,7cST	Displacement	4cm ³ / 0,24cu.in
Oil quantity	170cm ³ / 5,7fl.oz	Compressors on pallet	100
Refr. charge - tech. limit	200g / 7,1oz		
Free gas volume comp.	1630cm ³ / 55,1fl.oz		
Weight	8,3kg / 18,3lbs		
Motor protection	external		
Winding resistance main	3,4Ω (at 25°C)		
Winding resistance aux	8Ω (at 25°C)		
Max. winding temp.	125°C / 257°F		
Max. discharge temp.	130°C / 266°F		
Additional note	Very good robustness against liquid intake. Ice-cube maker optimization - indirect suction intake.		



General - Configurations with KLF4.0CNHS

	Conf. 1
Motorconfiguration	CSIR
Power supply (nominal)	115-127V/60Hz
Number of phases	1
Voltage range	95-140V
Approvals	UL, CCC
Starting torque	HST
Note	- / -

Applications with KLF4.0CNHS

	Conf. 1
Refrigerant	R290
Application	LBP+MBP
System cooling	fan 3m/s
Hot gas defrost	OK
Long interval pull down	OK

Electrical data - Configurations with KLF4.0CNHS

	Conf. 1
Starting device type	relay
Run capacitor	-/-
Start capacitor	240μF
LRA (locked rotor amps / 4s/ U(N))	21,2A
RLA (rated load amps / 1s/ U(N))	2,7A
Cut in current (U(N))	20,5A

Model

Designation	KLF4.0CNHS	115-127V/60Hz 1~	Sales code:	106H3403
-------------	-------------------	------------------	-------------	-----------------

Compressor dimensions

Housing	A Height	182mm / 7,17in
	B Height	175mm / 6,89in
	C Length shell	198mm / 7,8in
	D Length w. cover	238mm / 9,37in
	E Width	160mm / 6,3in

Connectors		Suction	Discharge	Process
		X	Y	Z
Diameter	[mm]	øi 8,11-8,29	øi 6,41-6,59	øi 6,41-6,59
	(i:inside, o:outside) [in]	øi 0,32-0,33	øi 0,25-0,26	øi 0,25-0,26
Material		copper	copper	copper
Horizontal angle	±2°	35°	13°	0°
Vertical angle	±2°	30°	40°	145°
Position l/h/w	[mm]	120/72/57	112/106/81	-97/94/72
	[in]	4,7/2,8/2,2	4,4/4,2/3,2	-3,8/3,7/2,8
Straight tube l.	[mm]	14	14	14
	[in]	0,5	0,5	0,5

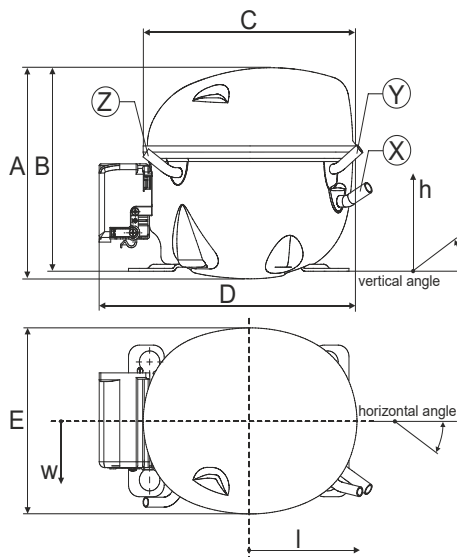

Compressor fixation

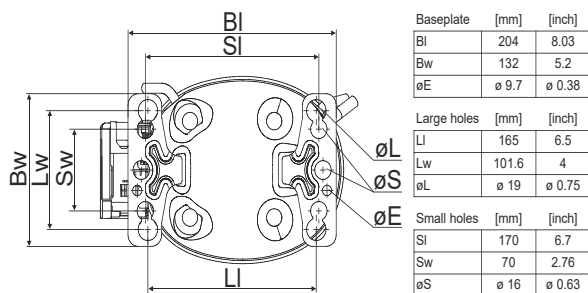

Bolt joint

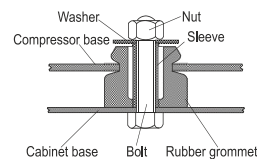

Snap-on

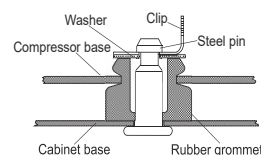

Mounting accessories	one comp.	multi pack
Bolt joint M6 ø16mm	118-1917	118-1918
Bolt joint ø1/4" ø16mm	118-1946	
Bolt joint ø1/4" ø19mm	118-1949	
Snap-on ø7,3 ø16mm	118-1947	118-1919

Application notes

Provision for PE Grounding is located at the PE Stamp on the compressor

Model

Designation	KLF4.0CNHS	115-127V/60Hz	Conf. 1	Sales code:	106H3403
-------------	-------------------	----------------------	---------	-------------	-----------------

Configuration

Motorconfiguration	CSIR
Power supply (nominal)	115-127V/60Hz 1~
Refrigerant	R290
Application	LBP+MBP
Voltage range	95-140V
Starting torque	HST
Approvals	UL CCC

Electrical accessories / wiring diagram

CSIR

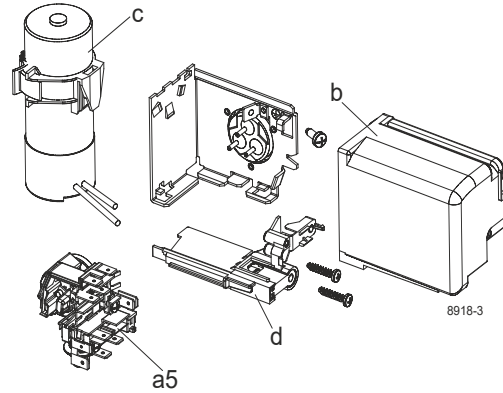

Ambient/ machine room temperatures minimum /maximum

Ambient temperature range: 10 - 43°C / 50 - 110°F

Machine room temperature range: 10 - 48°C / 50 - 119°F

Compressor cooling: fan 3m/s

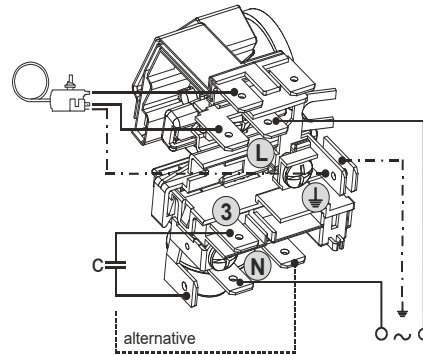

Operation pressure range

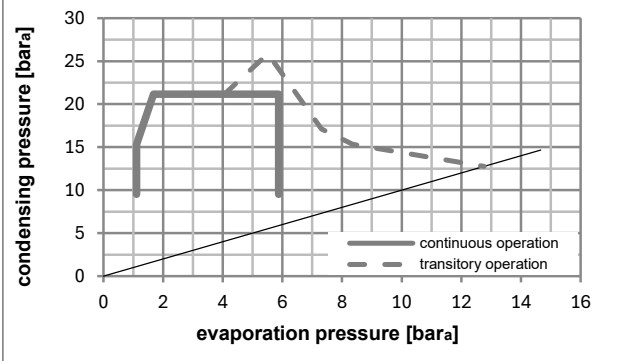
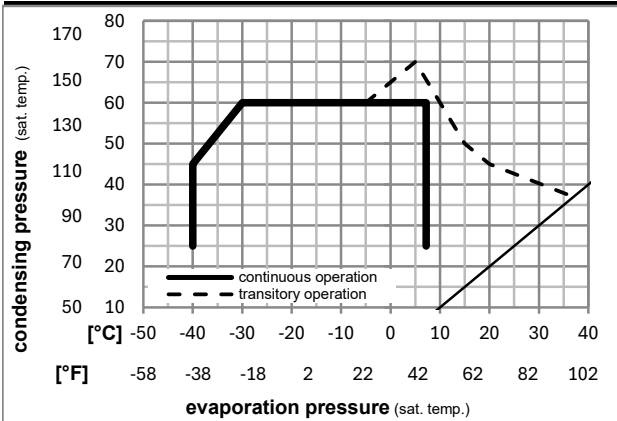

Components

a5	current relay (T1209/L6-S4)	117U7074
c	start capacitor (240µF)	117U5002
b, d	cover + clamp + screws(5VA) in bag	103N1060

Alternative components

b, d	100x cover + clamp + screws(5VA)	103N2060
b, d	cover + clamp + screws(5VA-compl.)	103N0600

Model

Designation **KLF4.0CNHS** **115-127V/60Hz** Conf. 1 Sales code: **106H3403**

Optimization + standard conditions

R290, 115V/60Hz, CSIR, fan 3m/s, UL, CCC

Evaporating pressure (saturation temperature)				Condensing pressure (saturation temperature)			Power consumption					ASHRAE LBP		
Return gas temp.				Liquid temp.			Current consumption						Ref. mass flow	
pe	pc	RGT	Tliq	[W]	[Btu/h]	[kcal/h]	COP	EER	[kcal/Wh]	P1	I			m
[°C]	[°C]	[°C]	[°C]	[W]	[Btu/h]	[kcal/h]	[W/W]	[Btu/Wh]	[kcal/Wh]	[W]	[A]	[kg/h]		
-23	54	32	32	220,0	751	189,3	1,45	4,96	1,25	151,5	1,90	2,23	ASHRAE LBP	
-10	130	90	90											
[°C]	-25	55	32	55	163,5	558	140,7	1,11	3,80	0,96	147,0	1,87	2,04	cecomaf LBP
[°F]	-13	131	90	131										
[°C]	-35	40	20	40	122,7	419	105,6	1,02	3,49	0,88	120,0	1,71	1,40	EN12900 LBP
[°F]	-31	104	68	104										
[°C]	-7	54	35	46	403,8	1379	347,5	2,04	6,96	1,75	198,1	2,22	4,61	ASHRAE MBP
[°F]	20	130	95	115										
[°C]	-10	55	32	55	320,0	1093	275,4	1,68	5,73	1,44	190,6	2,17	4,05	cecomaf MBP
[°F]	14	131	90	131										
[°C]	-10	45	20	45	362,8	1239	312,2	2,09	7,12	1,79	174,0	2,05	4,45	EN12900 MBP
[°F]	14	113	68	113										

Performance tables

R290, 115V/60Hz, CSIR, fan 3m/s, UL, CCC

	pe		Cooling capacity			COP			EER			P1	I	m
	[°C]	[°F]	[W]	[Btu/h]	[kcal/h]	[W/W]	[Btu/Wh]	[kcal/Wh]	[W]	[A]	[kg/h]			
[°C / °F]	-40	-40	78,9	269	67,9	0,69	2,37	0,60	113,8	1,69	0,88			
cond. pressure	-34	-30	118,4	404	101,9	0,97	3,31	0,83	122,1	1,73	1,33			
pc= 45/113	-23	-10	215,0	734	185,0	1,49	5,08	1,28	144,7	1,86	2,43			
return gas temp.	-15	5	309,4	1057	266,3	1,89	6,47	1,63	163,4	1,98	3,52			
RGT= 32/90	-4	25	475,1	1623	408,9	2,57	8,76	2,21	185,2	2,13	5,48			
liquid temp	0	32	546,1	1865	470,0	2,86	9,77	2,46	190,8	2,17	6,33			
Tliq= 45/113	7,2	45	698,7	2386	601,3	3,54	12,10	3,05	197,1	2,22	8,21			
[°C / °F]	-40	-40	51,1	175	44,0	0,47	1,61	0,40	108,7	1,65	0,63			
cond. pressure	-34	-30	89,7	306	77,2	0,74	2,53	0,64	121,2	1,72	1,11			
pc= 55/131	-23	-10	178,1	608	153,2	1,17	4,00	1,01	151,9	1,90	2,22			
return gas temp.	-15	5	260,9	891	224,5	1,48	5,05	1,27	176,5	2,07	3,28			
RGT= 32/90	-4	25	404,0	1380	347,7	1,96	6,70	1,69	206,0	2,28	5,16			
liquid temp	0	32	465,1	1588	400,2	2,17	7,42	1,87	214,2	2,35	5,97			
Tliq= 55/131	7,2	45	596,5	2037	513,4	2,65	9,05	2,28	225,2	2,43	7,77			