

Model

Designation	KLF4.0CNHS	115-127V/60Hz 1~	Sales code:	106H3413
-------------	-------------------	------------------	-------------	-----------------

Compressor design

Oil type	Polyolester	Refrigerant(s)	R290
Oil viscosity	10,4cSt	Displacement	4cm ³ / 0,24cu.in
Oil quantity	174cm ³ / 5,9fl.oz	Compressors on pallet	100
Refr. charge - tech. limit	200g / 7,1oz		
Free gas volume comp.	1630cm ³ / 55,1fl.oz		
Weight	8,3kg / 18,3lbs		
Motor protection	external		
Winding resistance main	3,4Ω (at 25°C)		
Winding resistance aux	8Ω (at 25°C)		
Max. winding temp.	125°C / 257°F		
Max. discharge temp.	130°C / 266°F		
Additional note	Very good robustness against liquid intake. Ice-cube maker optimization - indirect suction intake.		



General - Configurations with KLF4.0CNHS

	Conf. 1
Motorconfiguration	CSIR
Power supply (nominal)	115-127V/60Hz
Number of phases	1
Voltage range	95-140V
Approvals	UL, CCC
Starting torque	HST
Note	Electrical equipment is included and pre-assembled to compressor.

Applications with KLF4.0CNHS

	Conf. 1
Refrigerant	R290
Application	LBP+MBP
System cooling	fan 3m/s
Hot gas defrost	OK
Long interval pull down	OK

Electrical data - Configurations with KLF4.0CNHS

	Conf. 1
Starting device type	relay
Run capacitor	-/-
Start capacitor	240μF
LRA (locked rotor amps / 4s/ U(N))	21,2A
RLA (rated load amps / 1s/ U(N))	2,7A
Cut in current (U(N))	20,5A

Model

Designation

KLF4.0CNHS

115-127V/60Hz 1~

Sales code:

106H3413

Compressor dimensions

Housing	A Height	182mm / 7,17in
	B Height	175mm / 6,89in
	C Length shell	198mm / 7,8in
	D Length w. cover	238mm / 9,37in
	E Width	160mm / 6,3in

Connectors		Suction	Discharge	Process
		X	Y	Z
Diameter	[mm]	øi 8,11-8,29	øi 6,41-6,59	øi 6,41-6,59
(i:inside, o:outside)	[in]	øi 0,32-0,33	øi 0,25-0,26	øi 0,25-0,26
Material		copper	copper	copper
Horizontal angle	±2°	35°	13°	0°
Vertical angle	±2°	30°	40°	145°
Position l/h/w	[mm]	119/73/59	117/107/66	-88/101/71
	[in]	4,7/2,9/2,3	4,6/4,2/2,6	-3,5/4/2,8
Straight tube l.	[mm]	14	14	14
	[in]	0,5	0,5	0,5

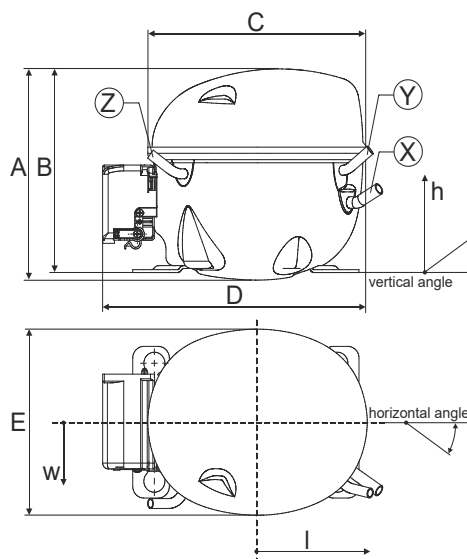

Compressor fixation

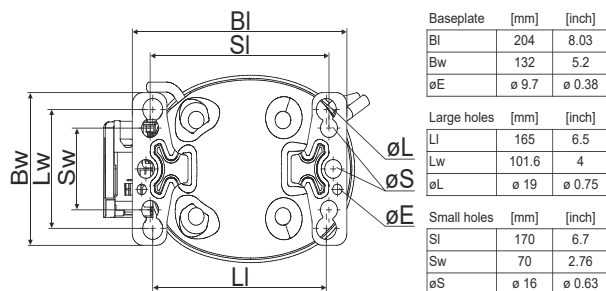

Bolt joint



Snap-on

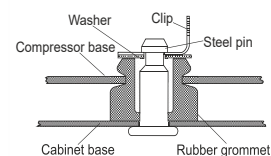

Mounting accessories	one comp.	multi pack
Bolt joint M6 ø16mm	118-1917	118-1918
Bolt joint ø1/4" ø16mm	118-1946	
Bolt joint ø1/4" ø19mm	118-1949	
Snap-on ø7,3 ø16mm	118-1947	118-1919

Application notes

Provision for PE Grounding is located at the PE Stamp on the compressor

Model

Designation	KLF4.0CNHS	115-127V/60Hz	Conf. 1	Sales code:	106H3413
-------------	-------------------	----------------------	----------------	-------------	-----------------

Configuration

Motorconfiguration	CSIR
Power supply (nominal)	115-127V/60Hz 1~
Refrigerant	R290
Application	LBP+MBP
Voltage range	95-140V
Starting torque	HST
Approvals	UL CCC

Electrical accessories / wiring diagram

CSIR



Ambient/ machine room temperatures minimum /maximum

Ambient temperature range:	10 - 43°C / 50 - 110°F
Machine room temperature range:	10 - 48°C / 50 - 119°F
Compressor cooling:	fan 3m/s

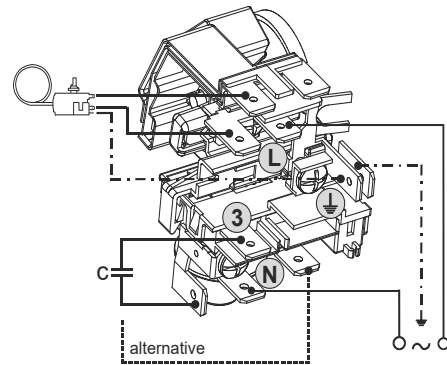

Operation pressure range

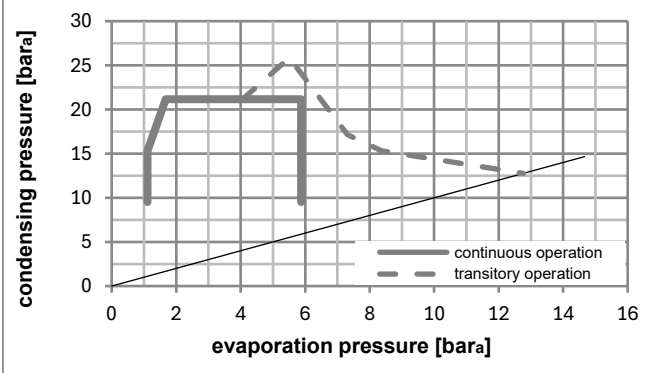
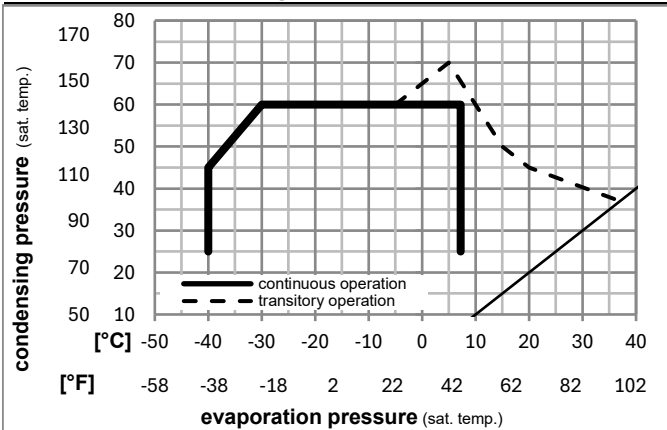

Components (already pre-assembled)

a5	current relay (T1209/L6-S4)	117U7074
c	start capacitor (240µF)	117U5002
b, d	cover + clamp + screws(5VA) in bag	103N1060

Alternative comp. (already pre-assembled)

b, d	100x cover + clamp + screws(5VA)	103N2060
b, d	cover + clamp + screws(5VA-compl.)	103N0600

Model

Designation **KLF4.0CNHS 115-127V/60Hz** Conf. 1 Sales code: **106H3413**

Optimization + standard conditions

R290, 115V/60Hz, CSIR, fan 3m/s, UL, CCC

	pe	pc	RGT	Tliq	Cooling capacity	COP	EER	P1	I	Ref. mass flow	
	[°C]	[°C]	[°C]	[°C]	[W]	[W/W]	[Btu/Wh]	[W]	[A]	[kg/h]	
ASHRAE LBP	-23	54	32	32	220,0	1,45	4,96	151,5	1,90	2,23	
	[°F]				[Btu/h]		[kcal/h]				
	-10	130	90	90	751	1,11	3,80	147,0	1,87	2,04	cecomaf LBP
	[°F]										
	-13	131	90	131	163,5	1,02	3,49	120,0	1,71	1,40	EN12900 LBP
	[°F]										
	-35	40	20	40	122,7	2,04	6,96	198,1	2,22	4,61	ASHRAE MBP
	[°F]										
	-31	104	68	104	403,8	1,68	5,73	190,6	2,17	4,05	cecomaf MBP
	[°F]										
	-7	54	35	46	403,8	2,09	7,12	174,0	2,05	4,45	EN12900 MBP
	[°F]										
	20	130	95	115	320,0	1,68	5,73	190,6	2,17	4,05	cecomaf MBP
	[°F]										
	-10	55	32	55	320,0	2,09	7,12	174,0	2,05	4,45	EN12900 MBP
	[°F]										
	14	131	90	131	1093	2,09	7,12	174,0	2,05	4,45	EN12900 MBP
	[°F]										
	14	113	68	113	362,8	2,09	7,12	174,0	2,05	4,45	EN12900 MBP
	[°F]										

Performance tables

R290, 115V/60Hz, CSIR, fan 3m/s, UL, CCC

	pe	Cooling capacity			COP	EER	P1	I	m		
	[°C]	[°F]	[W]	[Btu/h]	[kcal/h]	[W/W]	[Btu/Wh]	[kcal/Wh]	[W]	[A]	[kg/h]
[°C / °F]	-40	-40	78,9	269	67,9	0,69	2,37	0,60	113,8	1,69	0,88
cond. pressure	-34	-30	118,4	404	101,9	0,97	3,31	0,83	122,1	1,73	1,33
pc= 45/113	-23	-10	215,0	734	185,0	1,49	5,08	1,28	144,7	1,86	2,43
return gas temp.	-15	5	309,4	1057	266,3	1,89	6,47	1,63	163,4	1,98	3,52
RGT= 32/90	-4	25	475,1	1623	408,9	2,57	8,76	2,21	185,2	2,13	5,48
liquid temp	0	32	546,1	1865	470,0	2,86	9,77	2,46	190,8	2,17	6,33
Tliq= 45/113	7,2	45	698,7	2386	601,3	3,54	12,10	3,05	197,1	2,22	8,21
[°C / °F]	-40	-40	51,1	175	44,0	0,47	1,61	0,40	108,7	1,65	0,63
cond. pressure	-34	-30	89,7	306	77,2	0,74	2,53	0,64	121,2	1,72	1,11
pc= 55/131	-23	-10	178,1	608	153,2	1,17	4,00	1,01	151,9	1,90	2,22
return gas temp	-15	5	260,9	891	224,5	1,48	5,05	1,27	176,5	2,07	3,28
RGT= 32/90	-4	25	404,0	1380	347,7	1,96	6,70	1,69	206,0	2,28	5,16
liquid temp	0	32	465,1	1588	400,2	2,17	7,42	1,87	214,2	2,35	5,97
Tliq= 55/131	7,2	45	596,5	2037	513,4	2,65	9,05	2,28	225,2	2,43	7,77