

## Model

Designation	<b>KLF4.8CND</b>	220-240V/50Hz 1~	Sales code:	<b>106H2500</b>
-------------	------------------	------------------	-------------	-----------------

## Compressor design

Oil type	Polyolester	Refrigerant(s)	<b>R290</b>
Oil viscosity	9,7cST	Displacement	4,8cm <sup>3</sup> / 0,29cu.in
Oil quantity	170cm <sup>3</sup> / 5,7fl.oz	Compressors on pallet	100
Refr. charge - tech. limit	200g / 7,1oz		
Free gas volume comp.	1615cm <sup>3</sup> / 54,6fl.oz		
Weight	9,2kg / 20,3lbs		
Motor protection	external		
Winding resistance main	13,1Ω (at 25°C)		
Winding resistance aux	25,3Ω (at 25°C)		
Max. winding temp.	125°C / 257°F		
Max. discharge temp.	130°C / 266°F		



## General - Configurations with KLF4.8CND

	<b>Conf. 1</b>	<b>Conf. 2</b>
Motorconfiguration	CSIR	RSCR
Power supply (nominal)	220-240V/50Hz	220-240V/50Hz
Number of phases	1	1
Voltage range	198-254V	198-254V
Approvals	VDE, CCC	VDE, CCC
Starting torque	HST	LST
Note	- / -	

## Applications with KLF4.8CND

	<b>Conf. 1</b>	<b>Conf. 2</b>
Refrigerant	R290	R290
Application	LBP+MBP	LBP+MBP
System cooling	fan 3m/s	fan 3m/s
Hot gas defrost	OK	OK
Long interval pull down	OK	OK

## Electrical data - Configurations with KLF4.8CND

	<b>Conf. 1</b>	<b>Conf. 2</b>
Starting device type	relay	PTC
Run capacitor	-/-	5μF
Start capacitor	80μF	-/-
LRA (locked rotor amps / 4s)	10,2A	8A
RLA (rated load amps / 1s)	1,4A	
Cut in current	10,2A	12,65A

## Model

Designation

**KLF4.8CND**

220-240V/50Hz 1~

Sales code:

**106H2500**

## Compressor dimensions

Housing	A Height	182mm / 7,17in
	B Height	175mm / 6,89in
	C Length shell	198mm / 7,8in
	D Length w. cover	238mm / 9,37in
	E Width	160mm / 6,3in

Connectors		Suction	Discharge	Process
		X	Y	Z
Diameter	[mm]	øi 8,11-8,29	øi 6,11-6,29	øi 6,11-6,29
	(i:inside, o:outside) [in]	øi 0,32-0,33	øi 0,24-0,25	øi 0,24-0,25
Material		copper	copper	copper
Horizontal angle	±2°	35°	13°	0°
Vertical angle	±2°	30°	40°	145°
Position l/h/w	[mm]	120/72/57	112/106/81	-97/94/72
	[in]	4,7/2,8/2,2	4,4/4,2/3,2	-3,8/3,7/2,8
Straight tube l.	[mm]	14	14	14
	[in]	0,5	0,5	0,5

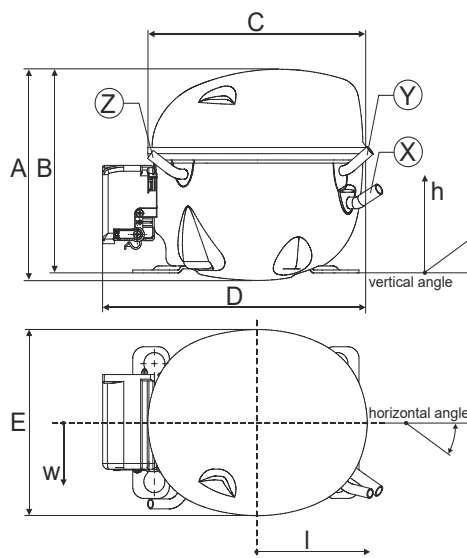

## Compressor fixation

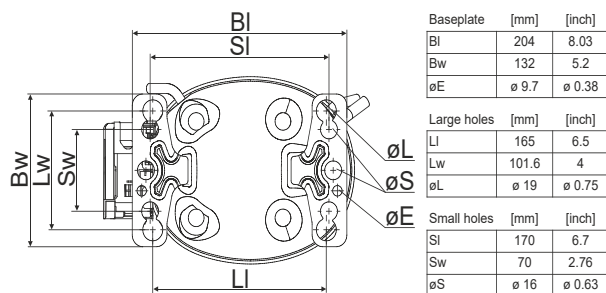

### Bolt joint

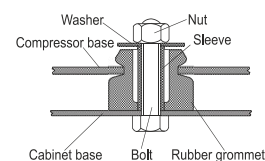

### Snap-on

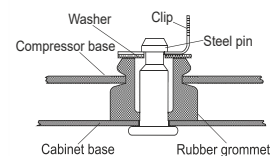

## Mounting accessories

	one comp.	multi pack
Bolt joint   M6   ø16mm	118-1917	118-1918
Bolt joint   ø1/4"   ø16mm	118-1946	
Bolt joint   ø1/4"   ø19mm	118-1949	
Snap-on   ø7,3   ø16mm	118-1947	118-1919

## Application notes

Provision for PE Grounding is located at the PE Stamp on the compressor

## Model

Designation	<b>KLF4.8CND</b>	<b>220-240V/50Hz</b>	Conf. 1	Sales code:	<b>106H2500</b>
-------------	------------------	----------------------	---------	-------------	-----------------

## Configuration

Motorconfiguration	CSIR
Power supply (nominal)	220-240V/50Hz 1~
Refrigerant	R290
Application	LBP+MBP
Voltage range	198-254V
Starting torque	HST
Approvals	VDE
	CCC

## Electrical accessories / wiring diagram

CSIR

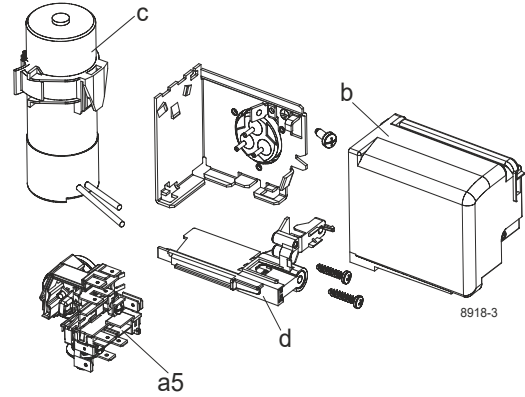

## Ambient/ machine room temperatures minimum /maximum

Ambient temperature range: 10 - 43°C / 50 - 110°F

Machine room temperature range: 10 - 48°C / 50 - 119°F

Compressor cooling: fan 3m/s

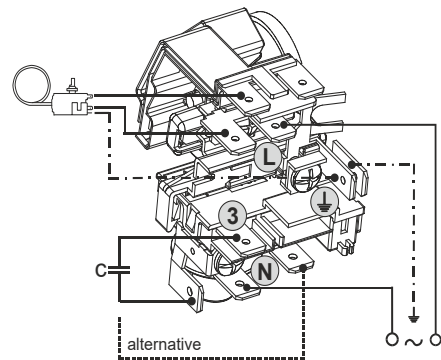

## Operation pressure range

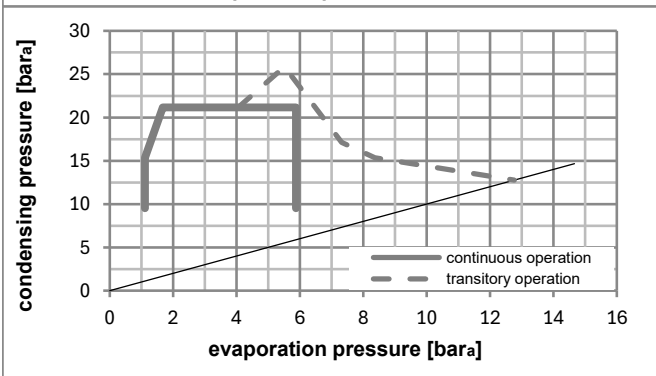
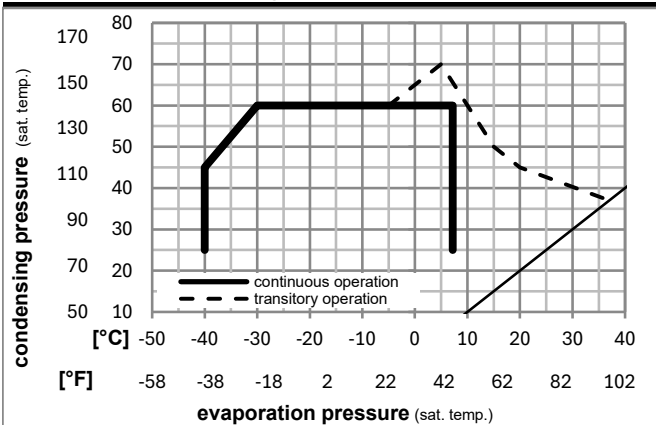

## Components

a5	current relay (T1189/L6-S3)	117U7073
c	start capacitor (80µF, 6.3mm)	117U5001
b, d	cover + clamp + screws(5VA) in bag	103N1060

## Alternative components

b, d	cover + clamp + screws(5VA-compl.)	103N0600
------	------------------------------------	----------

## Model

Designation	<b>KLF4.8CND</b>	<b>220-240V/50Hz</b>	<b>Conf. 1</b>	Sales code:	<b>106H2500</b>
-------------	------------------	----------------------	----------------	-------------	-----------------

## Optimization + standard conditions

R290, 220V/50Hz, CSIR, fan 3m/s, VDE, CCC

	Evaporating pressure (saturation temperature)				Cooling capacity			COP	EER	P1	Power consumption		ASHRAE LBP	
	pe	pc	RGT	Tliq	[W]	[Btu/h]	[kcal/h]				I	m		
	[°C]	[°F]	[°C]	[°F]	[W]	[Btu/h]	[kcal/h]	[W/W]	[Btu/Wh]	[kcal/Wh]	[W]	[A]	[kg/h]	
	-23	54	32	32	230,0	786	197,9	1,50	5,12	1,29	153,4	1,07	2,33	
	[°F]	-10	130	90										
	-25	55	32	55	171,4	585	147,5	1,15	3,93	0,99	148,9	1,06	2,13	cecomaf LBP
	[°F]	-13	131	90	131									
	-35	40	20	40	126,8	433	109,1	1,07	3,66	0,92	118,3	0,98	1,45	EN12900 LBP
	[°F]	-31	104	68	104									
	-7	54	35	46	410,2	1401	353,0	2,06	7,05	1,78	198,7	1,22	4,68	ASHRAE MBP
	[°F]	20	130	95	115									
	-10	55	32	55	326,0	1113	280,5	1,71	5,82	1,47	191,1	1,20	4,12	cecomaf MBP
	[°F]	14	131	90	131									
	-10	45	20	45	367,7	1256	316,4	2,13	7,27	1,83	172,7	1,13	4,51	EN12900 MBP
	[°F]	14	113	68	113									

## Performance tables

R290, 220V/50Hz, CSIR, fan 3m/s, VDE, CCC

	pe		Cooling capacity			COP	EER		P1	I	m
	[°C]	[°F]	[W]	[Btu/h]	[kcal/h]		[Btu/Wh]	[kcal/Wh]			
[°C / °F]	-40	-40	78,6	269	67,7	0,73	2,49	0,63	107,7	0,96	0,88
cond. pressure	-35	-31	119,0	406	102,4	0,99	3,39	0,85	120,0	0,98	1,33
pc= 45/113	-25	-13	207,0	707	178,1	1,45	4,95	1,25	142,9	1,04	2,33
return gas temp.	-15	5	316,1	1079	272,0	1,93	6,61	1,66	163,4	1,10	3,60
RGT= 32/90	-5	23	459,8	1570	395,7	2,54	8,66	2,18	181,4	1,16	5,29
liquid temp	0	32	548,9	1874	472,4	2,90	9,90	2,49	189,4	1,19	6,37
Tliq= 45/113	7,2	45	701,7	2396	603,9	3,51	12,00	3,02	199,7	1,23	8,24
[°C / °F]	-40	-40	51,9	177	44,6	0,51	1,73	0,44	102,5	0,94	0,64
cond. pressure	-35	-31	90,6	310	78,0	0,77	2,61	0,66	118,4	0,98	1,12
pc= 55/131	-25	-13	171,4	585	147,5	1,15	3,93	0,99	148,9	1,06	2,13
return gas temp	-15	5	267,7	914	230,4	1,51	5,15	1,30	177,5	1,15	3,37
RGT= 32/90	-5	23	393,2	1343	338,4	1,92	6,57	1,66	204,3	1,24	5,01
liquid temp	0	32	471,0	1609	405,4	2,17	7,42	1,87	216,9	1,29	6,05
Tliq= 55/131	7,2	45	605,3	2067	520,9	2,59	8,83	2,22	234,1	1,36	7,89

## Model

Designation	<b>KLF4.8CND</b>	<b>220-240V/50Hz</b>	<b>Conf. 2</b>	Sales code:	<b>106H2500</b>
-------------	------------------	----------------------	----------------	-------------	-----------------

## Configuration

Motorconfiguration	RSCR
Power supply (nominal)	220-240V/50Hz 1~
Refrigerant	R290
Application	LBP+MBP
Voltage range	198-254V
Starting torque	LST
Approvals	VDE CCC

## Electrical accessories / wiring diagram

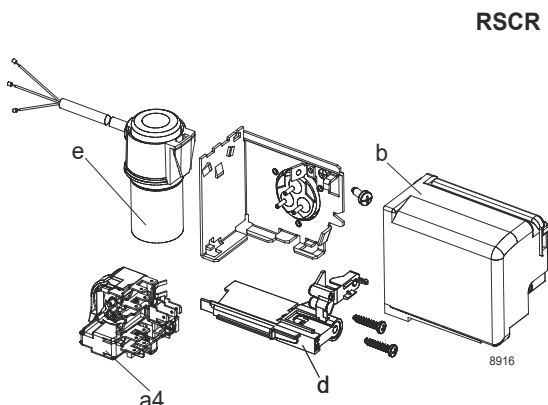

## Ambient/ machine room temperatures minimum /maximum

Ambient temperature range: 10 - 43°C / 50 - 110°F

Machine room temperature range: 10 - 48°C / 50 - 119°F

Compressor cooling: fan 3m/s

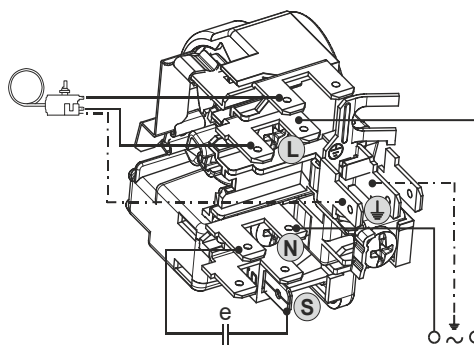

## Operation pressure range

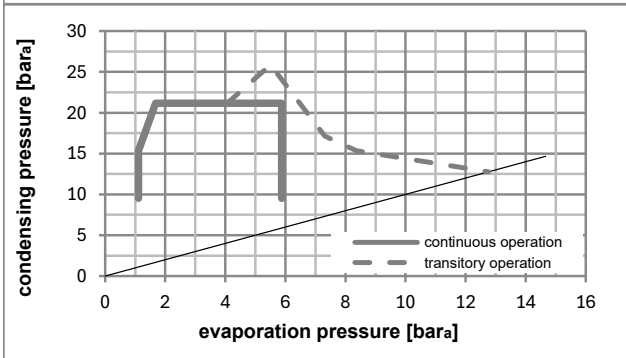
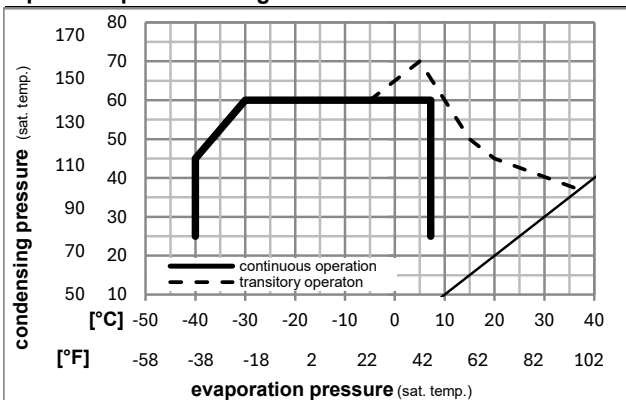

## Components

a4	DAS3 (PTC,6.3mm, T1189/L6 - S3)	103N0254
e	run capacitor (5μF, 6.3mm)	117-7191
b, d	cover + clamp + screws(5VA) in bag	103N1060

## Alternative components

a4	ZAS3 (PTC,4.8mm, T1189/L6 - S3)	103N0255
e	run capacitor (5μF, 4.8mm)	117-7190

b, d	cover + clamp + screws(5VA-compl.)	103N0600
------	------------------------------------	----------

### Model

Designation	<b>KLF4.8CND</b>	<b>220-240V/50Hz</b>	<b>Conf. 2</b>	Sales code:	<b>106H2500</b>
-------------	------------------	----------------------	----------------	-------------	-----------------

### Optimization + standard conditions

R290, 220V/50Hz, RSCR, fan 3m/s, VDE, CCC

		Evaporating pressure (saturation temperature)				Cooling capacity			COP			EER			Power consumption			
		Condensing pressure (saturation temperature)		Return gas temp.		Liquid temp.					Current consumption			Ref. mass flow				
		pe	pc	RGT	Tliq	[W]	[Btu/h]	[kcal/h]	[W/W]	[Btu/Wh]	[kcal/Wh]	P1	I	m	[W]	[A]	[kg/h]	
[°C]	-23	54	32	32	230,3	787	198,2	1,55	5,30	1,33	148,5	0,78	2,33	ASHRAE LBP				
[°F]	-10	130	90	90														
[°C]	-25	55	32	55	171,6	586	147,7	1,19	4,06	1,02	144,3	0,77	2,14	cecomaf LBP				
[°F]	-13	131	90	131														
[°C]	-35	40	20	40	126,9	433	109,2	1,09	3,73	0,94	116,1	0,66	1,45	EN12900 LBP				
[°F]	-31	104	68	104														
[°C]	-7	54	35	46	411,1	1404	353,8	2,17	7,40	1,87	189,7	0,95	4,69	ASHRAE MBP				
[°F]	20	130	95	115														
[°C]	-10	55	32	55	326,7	1116	281,1	1,79	6,10	1,54	182,9	0,92	4,13	cecomaf MBP				
[°F]	14	131	90	131														
[°C]	-10	45	20	45	368,3	1258	317,0	2,22	7,57	1,91	166,2	0,85	4,52	EN12900 MBP				
[°F]	14	113	68	113														

### Performance tables

R290, 220V/50Hz, RSCR, fan 3m/s, VDE, CCC

	pe		Cooling capacity			COP			EER			P1			I			m			
	[°C]	[°F]	[W]	[Btu/h]	[kcal/h]	[W/W]	[Btu/Wh]	[kcal/Wh]	[W]	[A]	[kg/h]	[W]	[A]	[kg/h]	[W]	[A]	[kg/h]	[W]	[A]	[kg/h]	
[°C / °F]	-40	-40	78,7	269	67,7	0,74	2,53	0,64	106,2	0,62	0,88										
cond. pressure	-35	-31	119,1	407	102,5	1,01	3,46	0,87	117,6	0,66	1,33										
pc= 45/113	-25	-13	207,2	708	178,3	1,49	5,10	1,28	138,9	0,74	2,34										
return gas temp.	-15	5	316,6	1081	272,5	2,01	6,85	1,73	157,7	0,82	3,60										
RGT= 32/90	-5	23	460,7	1573	396,5	2,65	9,04	2,28	174,1	0,89	5,30										
liquid temp	0	32	550,0	1878	473,3	3,03	10,35	2,61	181,4	0,92	6,38										
Tliq= 45/113	7,2	45	703,3	2402	605,3	3,69	12,59	3,17	190,8	0,96	8,26										
[°C / °F]	-40	-40	51,9	177	44,7	0,51	1,75	0,44	101,4	0,61	0,64										
cond. pressure	-35	-31	90,7	310	78,1	0,78	2,67	0,67	116,2	0,66	1,12										
pc= 55/131	-25	-13	171,6	586	147,7	1,19	4,06	1,02	144,3	0,77	2,14										
return gas temp	-15	5	268,2	916	230,8	1,57	5,37	1,35	170,5	0,87	3,37										
RGT= 32/90	-5	23	394,1	1346	339,2	2,02	6,91	1,74	194,7	0,97	5,02										
liquid temp	0	32	472,3	1613	406,5	2,29	7,83	1,97	206,1	1,02	6,07										
Tliq= 55/131	7,2	45	607,1	2073	522,5	2,74	9,36	2,36	221,6	1,09	7,91										