

Model

Designation	KLF4.8CND	220-240V/50Hz 1~	Sales code:	106H2508
-------------	------------------	-------------------------	-------------	-----------------

Compressor design

Oil type	Polyolester	Refrigerant(s)	R290
Oil viscosity	10,4cSt	Displacement	4,8cm ³ / 0,29cu.in
Oil quantity	170cm ³ / 5,7fl.oz	Compressors on pallet	100
Refr. charge - tech. limit	200g / 7,1oz		
Free gas volume comp.	1615cm ³ / 54,6fl.oz		
Weight	8,66kg / 19,1lbs		
Motor protection	external		
Winding resistance main	13,1Ω (at 25°C)		
Winding resistance aux	25,3Ω (at 25°C)		
Max. winding temp.	125°C / 257°F		
Max. discharge temp.	130°C / 266°F		



General - Configurations with KLF4.8CND

	Conf. 1	Conf. 2
Motorconfiguration	CSIR	RSCR
Power supply (nominal)	220-240V/50Hz	220-240V/50Hz
Number of phases	1	1
Voltage range	198-254V	198-254V
Approvals	VDE, CCC	VDE, CCC
Starting torque	HST	LST
Note	Compressor with low height version.	

Applications with KLF4.8CND

	Conf. 1	Conf. 2
Refrigerant	R290	R290
Application	LBP+MBP	LBP+MBP
System cooling	fan 3m/s	fan 3m/s
Hot gas defrost	OK	OK
Long interval pull down	OK	OK

Electrical data - Configurations with KLF4.8CND

	Conf. 1	Conf. 2
Starting device type	relay	PTC
Run capacitor	-/-	5μF
Start capacitor	80μF	-/-
LRA (locked rotor amps / 4s/ U(N))	10,2A	10,2A
RLA (rated load amps / 1s/ U(N))	1,4A	1,4A
Cut in current (U(N))	10,2A	12,65A

Model

Designation

KLF4.8CND

220-240V/50Hz 1~

Sales code:

106H2508

Compressor dimensions

Housing	A Height	174mm / 6,85in
	B Height	167mm / 6,57in
	C Length shell	194mm / 7,64in
	D Length w. cover	235,1mm / 9,26in
	E Width	151mm / 5,94in

Connectors		Suction	Discharge	Process
		X	Y	Z
Diameter	[mm]	øi 8,11-8,29	øi 6,11-6,29	øi 6,11-6,29
(i:inside, o:outside)	[in]	øi 0,32-0,33	øi 0,24-0,25	øi 0,24-0,25
Material		copper	copper	copper
Horizontal angle	±2°	35°	13°	0°
Vertical angle	±2°	30°	40°	145°
Position l/h/w	[mm]	119/73/59	114/107/63	-87/101/71
	[in]	4,7/2,9/2,3	4,5/4,2/2,5	-3,4/4/2,8
Straight tube l.	[mm]	14	14	14
	[in]	0,5	0,5	0,5

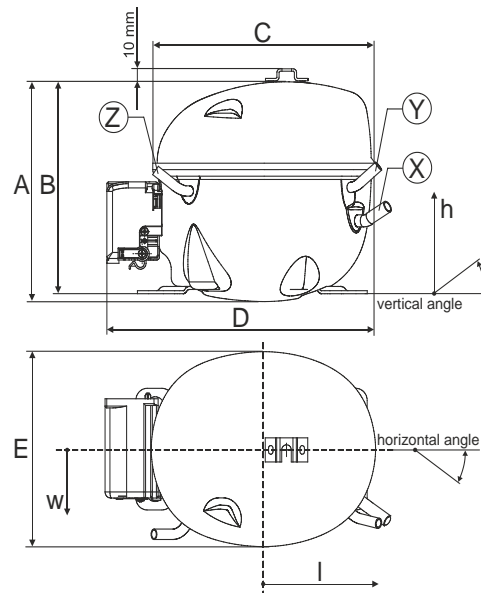

Compressor fixation

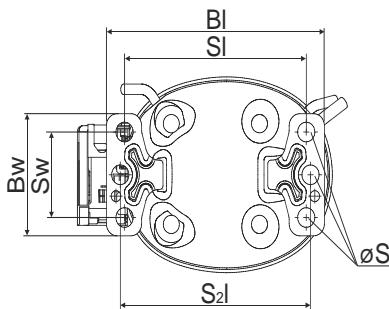

Baseplate	[mm]	[inch]
BI	204	8.03
Bw	100	3.94
Small holes	[mm]	[inch]
SI	170	6.7
Sw	70	2.76
S2l	178	7
øS	ø 16	ø 0.63

Bolt joint

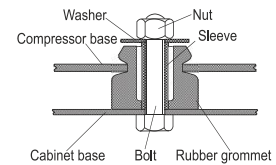

Snap-on

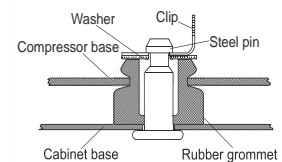

Mounting accessories	one comp.	multi pack
Bolt joint M6 ø16mm	118-1917	118-1918
Bolt joint ø1/4" ø16mm	118-1946	
Snap-on ø7,3 ø16mm	118-1947	118-1919

Application notes

Provision for PE Grounding is located at the PE Stamp on the compressor

Model

Designation	KLF4.8CND	220-240V/50Hz	Conf. 1	Sales code:	106H2508
-------------	------------------	----------------------	---------	-------------	-----------------

Configuration

Motorconfiguration	CSIR
Power supply (nominal)	220-240V/50Hz 1~
Refrigerant	R290
Application	LBP+MBP
Voltage range	198-254V
Starting torque	HST
Approvals	VDE CCC

Electrical accessories / wiring diagram

CSIR

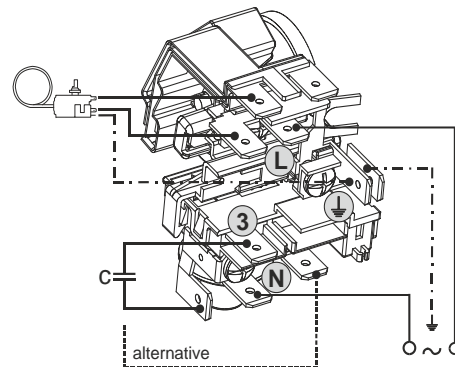
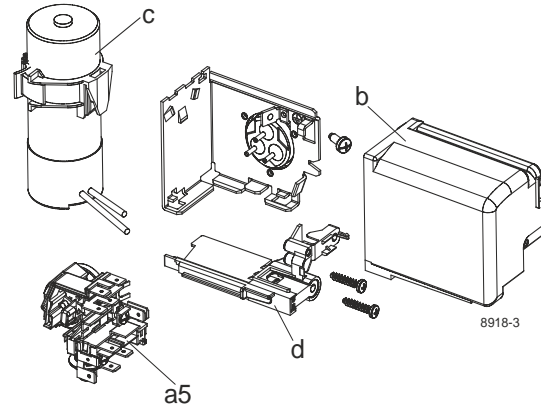

Ambient/ machine room temperatures minimum /maximum

Ambient temperature range:	10 - 43°C / 50 - 110°F
Machine room temperature range:	10 - 48°C / 50 - 119°F
Compressor cooling:	fan 3m/s

Operation pressure range

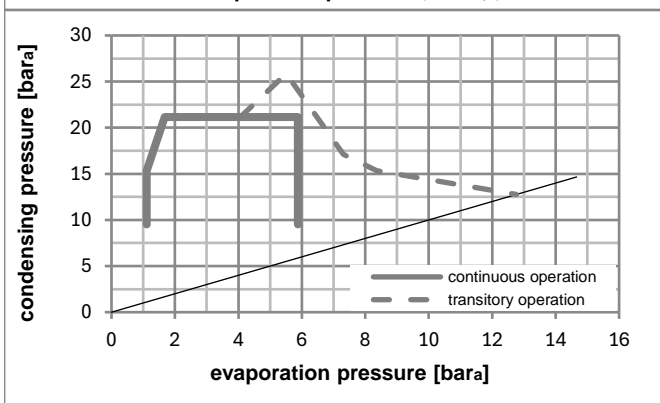
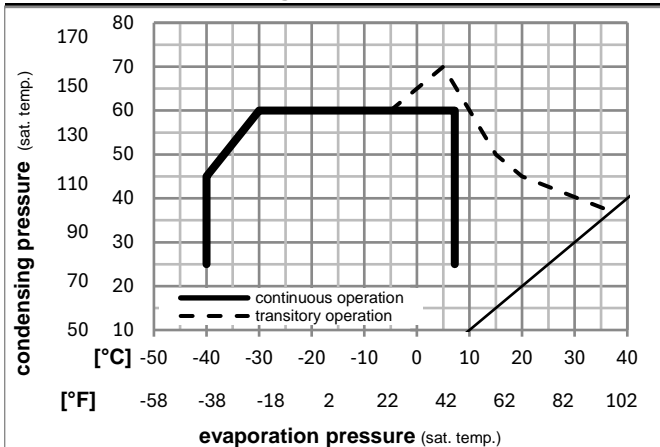

Components

a5	current relay (T1189/L6-S3)	117U7073
c	start capacitor (80µF, 6.3mm)	117U5001
b, d	cover + clamp + screws(5VA-compl.)	103N0600

Alternative components

b, d	100x cover + clamp + screws(5VA)	103N2060
b, d	cover + clamp + screws(5VA) in bag	103N1060

Model

Designation **KLF4.8CND** **220-240V/50Hz** Conf. 1 Sales code: **106H2508**

Optimization + standard conditions

R290, 220V/50Hz, CSIR, fan 3m/s, VDE, CCC

	pe	pc	RGT	Tliq	Cooling capacity		COP	EER		P1	I	Ref. mass flow	
	[°C]	[°C]	[°C]	[°C]	[W]	[Btu/h]	[W/W]	[Btu/Wh]	[kcal/Wh]	[W]	[A]	[kg/h]	
Evaporating pressure (saturation temperature)	-23	54	32	32	230,0	786	1,50	5,12	1,29	153,4	1,07	2,33	ASHRAE LBP
Condensing pressure (saturation temperature)	-10	130	90	90									
Return gas temp.													
Liquid temp.													
	[°F]	[°F]	[°F]	[°F]									
	-7	54	35	46	410,2	1401	2,06	7,05	1,78	198,7	1,22	4,68	ASHRAE MBP
	20	130	95	115									
	[°C]	[°C]	[°C]	[°C]									
	-10	55	32	55	326,0	1113	1,71	5,82	1,47	191,1	1,20	4,12	cecomaf MBP
	14	131	90	131									
	[°F]	[°F]	[°F]	[°F]									
	-35	40	20	40	126,8	433	1,07	3,66	0,92	118,3	0,98	1,45	EN12900 LBP
	-31	104	68	104									
	[°F]	[°F]	[°F]	[°F]									
	-10	55	32	55	326,0	1113	1,71	5,82	1,47	191,1	1,20	4,12	cecomaf MBP
	14	131	90	131									
	[°F]	[°F]	[°F]	[°F]									
	-10	45	20	45	367,7	1256	2,13	7,27	1,83	172,7	1,13	4,51	EN12900 MBP
	14	113	68	113									
	[°F]	[°F]	[°F]	[°F]									

Performance tables

R290, 220V/50Hz, CSIR, fan 3m/s, VDE, CCC

	pe	Cooling capacity			COP	EER			P1	I	m
	[°C]	[°F]	[W]	[Btu/h]	[kcal/h]	[W/W]	[Btu/Wh]	[kcal/Wh]	[W]	[A]	[kg/h]
[°C / °F]	-35	-31	119,0	406	102,4	0,99	3,39	0,85	120,0	0,98	1,33
cond. pressure	-35	-31	119,0	406	102,4	0,99	3,39	0,85	120,0	0,98	1,33
pc= 45/113	-25	-13	207,0	707	178,1	1,45	4,95	1,25	142,9	1,04	2,33
return gas temp.	-15	5	316,1	1079	272,0	1,93	6,61	1,66	163,4	1,10	3,60
RGT= 32/90	-5	23	459,8	1570	395,7	2,54	8,66	2,18	181,4	1,16	5,29
liquid temp	0	32	548,9	1874	472,4	2,90	9,90	2,49	189,4	1,19	6,37
Tliq= 45/113	7,2	45	701,7	2396	603,9	3,51	12,00	3,02	199,7	1,23	8,24
[°C / °F]	-35	-31	90,6	310	78,0	0,77	2,61	0,66	118,4	0,98	1,12
cond. pressure	-35	-31	90,6	310	78,0	0,77	2,61	0,66	118,4	0,98	1,12
pc= 55/131	-25	-13	171,4	585	147,5	1,15	3,93	0,99	148,9	1,06	2,13
return gas temp	-15	5	267,7	914	230,4	1,51	5,15	1,30	177,5	1,15	3,37
RGT= 32/90	-5	23	393,2	1343	338,4	1,92	6,57	1,66	204,3	1,24	5,01
liquid temp	0	32	471,0	1609	405,4	2,17	7,42	1,87	216,9	1,29	6,05
Tliq= 55/131	7,2	45	605,3	2067	520,9	2,59	8,83	2,22	234,1	1,36	7,89

Model

Designation **KLF4.8CND** **220-240V/50Hz** Conf. 2 Sales code: **106H2508**

Configuration

Motorconfiguration RSCR
 Power supply (nominal) 220-240V/50Hz 1~
 Refrigerant R290
 Application LBP+MBP
 Voltage range 198-254V
 Starting torque LST
 Approvals VDE
 CCC

Electrical accessories / wiring diagram

RSCR

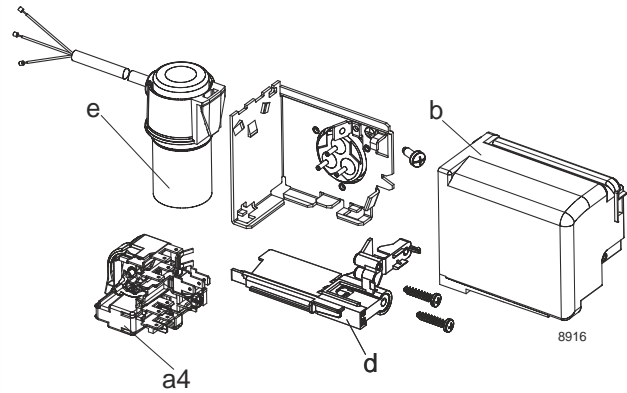

Ambient/ machine room temperatures minimum /maximum

Ambient temperature range: 10 - 43°C / 50 - 110°F

Machine room temperature range: 10 - 48°C / 50 - 119°F

Compressor cooling: fan 3m/s

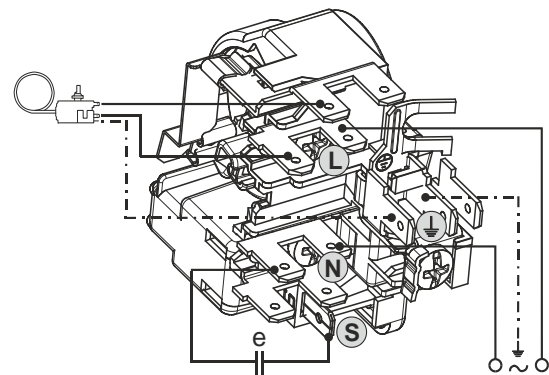

Operation pressure range

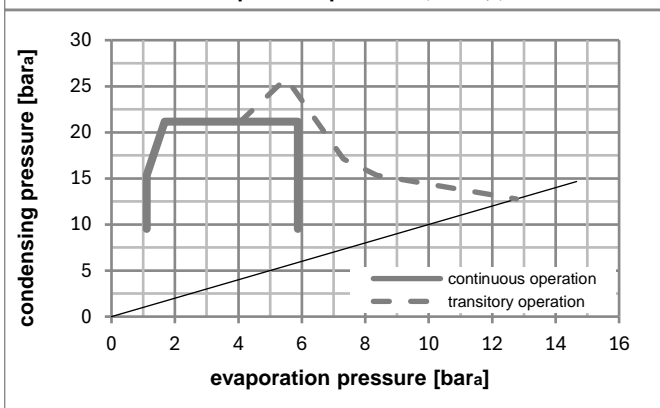
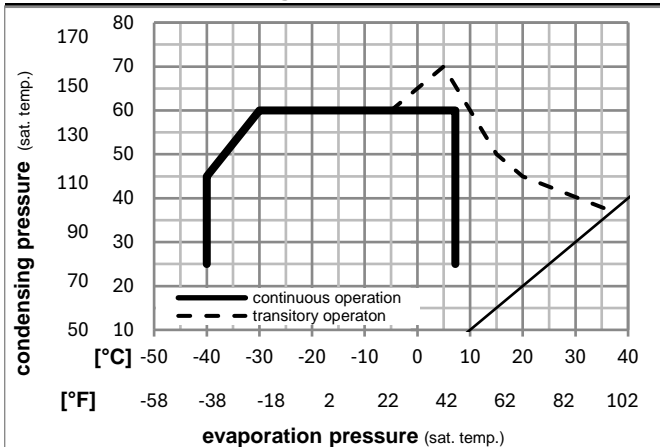

Components

a4	DAS3 (PTC,6.3mm, T1189/L6 - S3)	103N0254
e	run capacitor (5μF, 6.3mm)	117-7191
b, d	cover + clamp + screws(5VA-compl.)	103N0600

Alternative components

a4	ZAS3 (PTC,4.8mm, T1189/L6 - S3)	103N0255
e	run capacitor (5μF, 4.8mm)	117-7190
b, d	100x cover + clamp + screws(5VA)	103N2060
b, d	cover + clamp + screws(5VA) in bag	103N1060

Model

Designation **KLF4.8CND** **220-240V/50Hz** Conf. 2 Sales code: **106H2508**

Optimization + standard conditions

R290, 220V/50Hz, RSCR, fan 3m/s, VDE, CCC

		Evaporating pressure (saturation temperature)				Condensing pressure (saturation temperature)			Return gas temp.		Liquid temp.		Cooling capacity			COP	EER	Power consumption			Ref. mass flow
		pe	pc	RGT	Tliq	[W]	[Btu/h]	[kcal/h]	[W/W]	[Btu/Wh]	[kcal/Wh]	[W]	I	m			P1	I	m		
[°C]	[°F]	[°C]	[°F]	[°C]	[°C]							[A]	[kg/h]								
-23	54	32	32	230,3	787	198,2	1,55	5,30	1,33	148,5	0,78	2,33	ASHRAE LBP								
-10	130	90	90																		
-25	55	32	55	171,6	586	147,7	1,19	4,06	1,02	144,3	0,77	2,14	cecomaf LBP								
-13	131	90	131																		
-35	40	20	40	126,9	433	109,2	1,09	3,73	0,94	116,1	0,66	1,45	EN12900 LBP								
-31	104	68	104																		
-7	54	35	46	411,1	1404	353,8	2,17	7,40	1,87	189,7	0,95	4,69	ASHRAE MBP								
20	130	95	115																		
-10	55	32	55	326,7	1116	281,1	1,79	6,10	1,54	182,9	0,92	4,13	cecomaf MBP								
14	131	90	131																		
-10	45	20	45	368,3	1258	317,0	2,22	7,57	1,91	166,2	0,85	4,52	EN12900 MBP								
14	113	68	113																		

Performance tables

R290, 220V/50Hz, RSCR, fan 3m/s, VDE, CCC

	pe		Cooling capacity			COP	EER		P1	I	m
	[°C]	[°F]	[W]	[Btu/h]	[kcal/h]	[W/W]	[Btu/Wh]	[kcal/Wh]	[W]	[A]	[kg/h]
[°C / °F]	-40	-40	78,7	269	67,7	0,74	2,53	0,64	106,2	0,62	0,88
cond. pressure	-35	-31	119,1	407	102,5	1,01	3,46	0,87	117,6	0,66	1,33
pc= 45/113	-25	-13	207,2	708	178,3	1,49	5,10	1,28	138,9	0,74	2,34
return gas temp.	-15	5	316,6	1081	272,5	2,01	6,85	1,73	157,7	0,82	3,60
RGT= 32/90	-5	23	460,7	1573	396,5	2,65	9,04	2,28	174,1	0,89	5,30
liquid temp	0	32	550,0	1878	473,3	3,03	10,35	2,61	181,4	0,92	6,38
Tliq= 45/113	7,2	45	703,3	2402	605,3	3,69	12,59	3,17	190,8	0,96	8,26
[°C / °F]	-40	-40	51,9	177	44,7	0,51	1,75	0,44	101,4	0,61	0,64
cond. pressure	-35	-31	90,7	310	78,1	0,78	2,67	0,67	116,2	0,66	1,12
pc= 55/131	-25	-13	171,6	586	147,7	1,19	4,06	1,02	144,3	0,77	2,14
return gas temp	-15	5	268,2	916	230,8	1,57	5,37	1,35	170,5	0,87	3,37
RGT= 32/90	-5	23	394,1	1346	339,2	2,02	6,91	1,74	194,7	0,97	5,02
liquid temp	0	32	472,3	1613	406,5	2,29	7,83	1,97	206,1	1,02	6,07
Tliq= 55/131	7,2	45	607,1	2073	522,5	2,74	9,36	2,36	221,6	1,09	7,91