

Model

Designation	KLF4.8CND	220-240V/50Hz 1~	Sales code:	106H2510
-------------	------------------	------------------	-------------	-----------------

Compressor design

Oil type	Polyolester	Refrigerant(s)	R290
Oil viscosity	9,7cST	Displacement	4,8cm ³ / 0,29cu.in
Oil quantity	170cm ³ / 5,7fl.oz	Compressors on pallet	100
Refr. charge - tech. limit	200g / 7,1oz		
Free gas volume comp.	1615cm ³ / 54,6fl.oz		
Weight	9,2kg / 20,3lbs		
Motor protection	external		
Winding resistance main	13,1Ω (at 25°C)		
Winding resistance aux	25,3Ω (at 25°C)		
Max. winding temp.	125°C / 257°F		
Max. discharge temp.	130°C / 266°F		



General - Configurations with KLF4.8CND

	Conf. 1
Motorconfiguration	CSIR
Power supply (nominal)	220-240V/50Hz
Number of phases	1
Voltage range	198-254V
Approvals	VDE, CCC
Starting torque	HST
Note	Electrical equipment is included and pre-assembled to compressor.

Applications with KLF4.8CND

	Conf. 1
Refrigerant	R290
Application	LBP+MBP
System cooling	fan 3m/s
Hot gas defrost	OK
Long interval pull down	OK

Electrical data - Configurations with KLF4.8CND

	Conf. 1
Starting device type	relay
Run capacitor	-/-
Start capacitor	80μF
LRA (locked rotor amps / 4s)	10,2A
RLA (rated load amps / 1s)	1,4A
Cut in current	10,2A

Model

Designation

KLF4.8CND

220-240V/50Hz 1~

Sales code:

106H2510

Compressor dimensions

Housing	A Height	182mm / 7,17in
	B Height	175mm / 6,89in
	C Length shell	198mm / 7,8in
	D Length w. cover	238mm / 9,37in
	E Width	160mm / 6,3in

Connectors		Suction	Discharge	Process
		X	Y	Z
Diameter	[mm]	øi 8,11-8,29	øi 6,11-6,29	øi 6,11-6,29
	(i:inside, o:outside) [in]	øi 0,32-0,33	øi 0,24-0,25	øi 0,24-0,25
Material		copper	copper	copper
Horizontal angle	±2°	35°	13°	0°
Vertical angle	±2°	30°	40°	145°
Position l/h/w	[mm]	120/72/57	112/106/81	-97/94/72
	[in]	4,7/2,8/2,2	4,4/4,2/3,2	-3,8/3,7/2,8
Straight tube l.	[mm]	14	14	14
	[in]	0,5	0,5	0,5

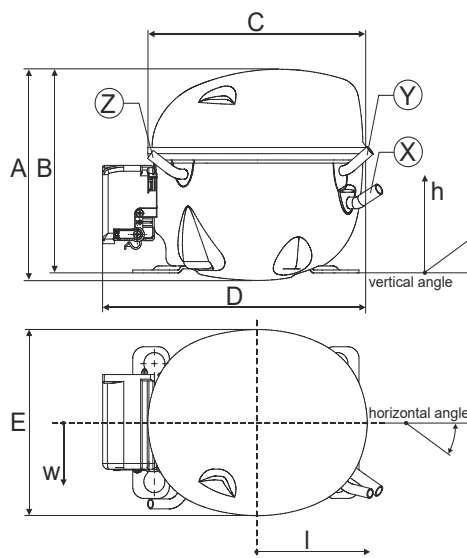

Compressor fixation

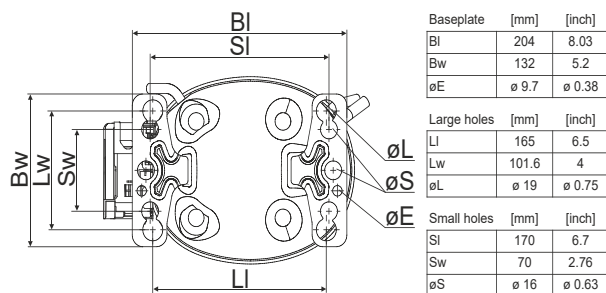

Bolt joint

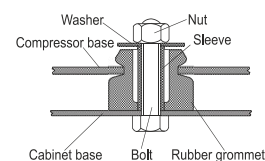

Snap-on

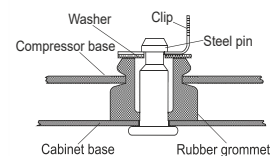

Mounting accessories

	one comp.	multi pack
Bolt joint M6 ø16mm	118-1917	118-1918
Bolt joint ø1/4" ø16mm	118-1946	
Bolt joint ø1/4" ø19mm	118-1949	
Snap-on ø7,3 ø16mm	118-1947	118-1919

Application notes

Provision for PE Grounding is located at the PE Stamp on the compressor

Model

Designation	KLF4.8CND	220-240V/50Hz	Conf. 1	Sales code:	106H2510
-------------	------------------	----------------------	---------	-------------	-----------------

Configuration

Motorconfiguration	CSIR
Power supply (nominal)	220-240V/50Hz 1~
Refrigerant	R290
Application	LBP+MBP
Voltage range	198-254V
Starting torque	HST
Approvals	VDE
	CCC

Electrical accessories / wiring diagram

CSIR

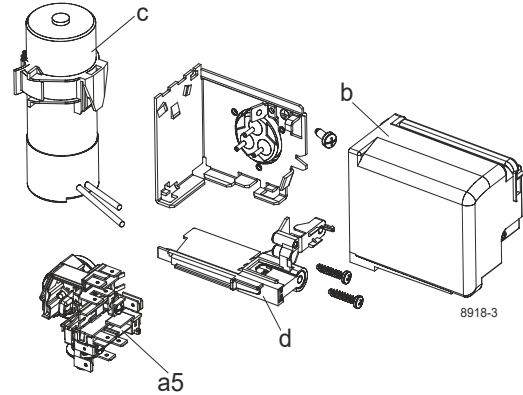

Ambient/ machine room temperatures minimum /maximum

Ambient temperature range: 10 - 43°C / 50 - 110°F

Machine room temperature range: 10 - 48°C / 50 - 119°F

Compressor cooling: fan 3m/s

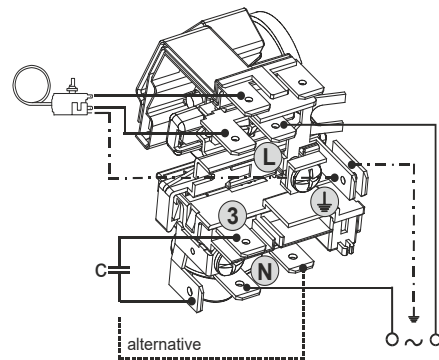

Operation pressure range

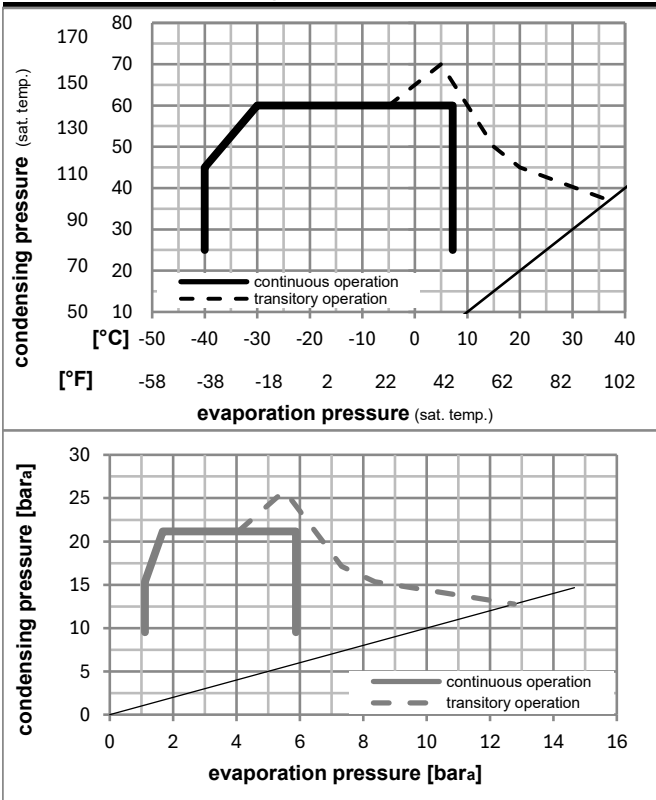

Components (already pre-assembled)

a5	current relay (T1189/L6-S3)	117U7073
c	start capacitor (80μF, 6.3mm)	117U5001
b	cover terminal board	10636401
.	screw uni en iso 4757	10641201

Alternative comp. (already pre-assembled)

.	cable clamp (screws not included)	16058100
.	screw - uni6954	10636000
.	screw - uni6954	10636200

Model

Designation	KLF4.8CND	220-240V/50Hz	Conf. 1	Sales code:	106H2510
-------------	------------------	----------------------	----------------	-------------	-----------------

Optimization + standard conditions

R290, 220V/50Hz, CSIR, fan 3m/s, VDE, CCC

	Evaporating pressure (saturation temperature)				Cooling capacity			COP	EER	P1	Power consumption		ASHRAE LBP	
	pe	pc	RGT	Tliq	[W]	[Btu/h]	[kcal/h]				I	m		
	[°C]	[°F]	[°C]	[°F]	[W]	[Btu/h]	[kcal/h]	[W/W]	[Btu/Wh]	[kcal/Wh]	[W]	[A]	[kg/h]	
	-23	54	32	32	230,0	786	197,9	1,50	5,12	1,29	153,4	1,07	2,33	
	[°F]	-10	130	90										
	-25	55	32	55	171,4	585	147,5	1,15	3,93	0,99	148,9	1,06	2,13	cecomaf LBP
	[°F]	-13	131	90										
	-35	40	20	40	126,8	433	109,1	1,07	3,66	0,92	118,3	0,98	1,45	EN12900 LBP
	[°F]	-31	104	68										
	-7	54	35	46	410,2	1401	353,0	2,06	7,05	1,78	198,7	1,22	4,68	ASHRAE MBP
	[°F]	20	130	95										
	-10	55	32	55	326,0	1113	280,5	1,71	5,82	1,47	191,1	1,20	4,12	cecomaf MBP
	[°F]	14	131	90										
	-10	45	20	45	367,7	1256	316,4	2,13	7,27	1,83	172,7	1,13	4,51	EN12900 MBP
	[°F]	14	113	68										

Performance tables

R290, 220V/50Hz, CSIR, fan 3m/s, VDE, CCC

	pe		Cooling capacity			COP	EER		P1	I	m
	[°C]	[°F]	[W]	[Btu/h]	[kcal/h]		[Btu/Wh]	[kcal/Wh]			
[°C / °F]	-40	-40	78,6	269	67,7	0,73	2,49	0,63	107,7	0,96	0,88
cond. pressure	-35	-31	119,0	406	102,4	0,99	3,39	0,85	120,0	0,98	1,33
pc= 45/113	-25	-13	207,0	707	178,1	1,45	4,95	1,25	142,9	1,04	2,33
return gas temp.	-15	5	316,1	1079	272,0	1,93	6,61	1,66	163,4	1,10	3,60
RGT= 32/90	-5	23	459,8	1570	395,7	2,54	8,66	2,18	181,4	1,16	5,29
liquid temp	0	32	548,9	1874	472,4	2,90	9,90	2,49	189,4	1,19	6,37
Tliq= 45/113	7,2	45	701,7	2396	603,9	3,51	12,00	3,02	199,7	1,23	8,24
[°C / °F]	-40	-40	51,9	177	44,6	0,51	1,73	0,44	102,5	0,94	0,64
cond. pressure	-35	-31	90,6	310	78,0	0,77	2,61	0,66	118,4	0,98	1,12
pc= 55/131	-25	-13	171,4	585	147,5	1,15	3,93	0,99	148,9	1,06	2,13
return gas temp	-15	5	267,7	914	230,4	1,51	5,15	1,30	177,5	1,15	3,37
RGT= 32/90	-5	23	393,2	1343	338,4	1,92	6,57	1,66	204,3	1,24	5,01
liquid temp	0	32	471,0	1609	405,4	2,17	7,42	1,87	216,9	1,29	6,05
Tliq= 55/131	7,2	45	605,3	2067	520,9	2,59	8,83	2,22	234,1	1,36	7,89