

Model

Designation	KLF4.8CNDS	220-240V/50Hz 1~	Sales code:	106H2503
-------------	-------------------	------------------	-------------	-----------------

Compressor design

Oil type	Polyolester	Refrigerant(s)	R290
Oil viscosity	10,4cSt	Displacement	4,8cm ³ / 0,29cu.in
Oil quantity	174cm ³ / 5,9fl.oz	Compressors on pallet	100
Refr. charge - tech. limit	200g / 7,1oz		
Free gas volume comp.	1615cm ³ / 54,6fl.oz		
Weight	9,2kg / 20,3lbs		
Motor protection	external		
Winding resistance main	13,1Ω (at 25°C)		
Winding resistance aux	25,3Ω (at 25°C)		
Max. winding temp.	125°C / 257°F		
Max. discharge temp.	130°C / 266°F		
Additional note	Very good robustness against liquid intake. Ice-cube maker optimization - indirect suction intake.		



General - Configurations with KLF4.8CNDS

	Conf. 1
Motorconfiguration	CSIR
Power supply (nominal)	220-240V/50Hz
Number of phases	1
Voltage range	198-254V
Approvals	VDE, CCC
Starting torque	HST
Note	- / -

Applications with KLF4.8CNDS

	Conf. 1
Refrigerant	R290
Application	LBP+MBP
System cooling	fan 3m/s
Hot gas defrost	OK
Long interval pull down	OK

Electrical data - Configurations with KLF4.8CNDS

	Conf. 1
Starting device type	relay
Run capacitor	-/-
Start capacitor	80μF
LRA (locked rotor amps / 4s/ U(N))	10,2A
RLA (rated load amps / 1s/ U(N))	1,4A
Cut in current (U(N))	10,2A

Model

Designation

KLF4.8CNDS

220-240V/50Hz 1~

Sales code:

106H2503

Compressor dimensions

Housing	A Height	182mm / 7,17in
	B Height	175mm / 6,89in
	C Length shell	198mm / 7,8in
	D Length w. cover	238mm / 9,37in
	E Width	160mm / 6,3in

Connectors		Suction	Discharge	Process
		X	Y	Z
Diameter	[mm]	øi 8,11-8,29	øi 6,11-6,29	øi 6,11-6,29
(i:inside, o:outside)	[in]	øi 0,32-0,33	øi 0,24-0,25	øi 0,24-0,25
Material		copper	copper	copper
Horizontal angle	±2°	35°	13°	0°
Vertical angle	±2°	30°	40°	145°
Position l/h/w	[mm]	119/73/59	117/107/66	-88/101/71
	[in]	4,7/2,9/2,3	4,6/4,2/2,6	-3,5/4/2,8
Straight tube l.	[mm]	14	14	14
	[in]	0,5	0,5	0,5

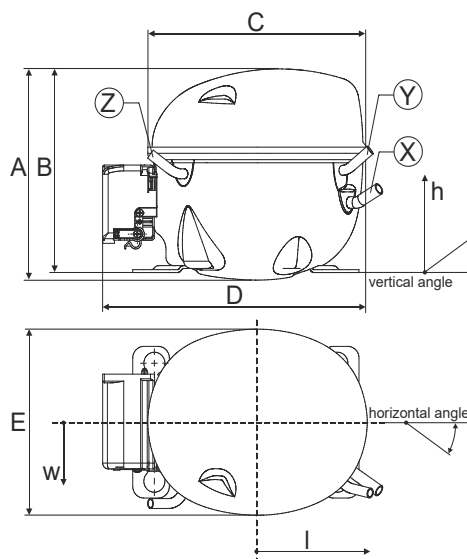

Compressor fixation

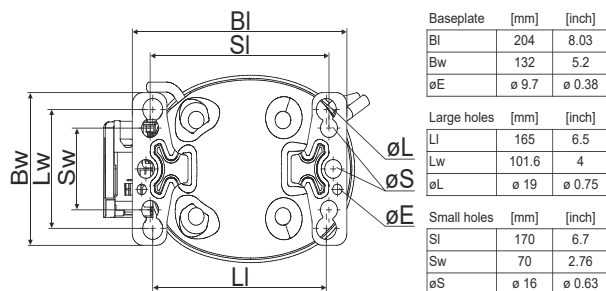

Bolt joint



Snap-on

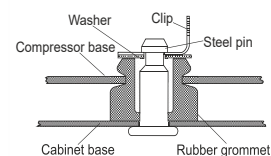

Mounting accessories

Mounting accessories	one comp.	multi pack
Bolt joint M6 ø16mm	118-1917	118-1918
Bolt joint ø1/4" ø16mm	118-1946	
Bolt joint ø1/4" ø19mm	118-1949	
Snap-on ø7,3 ø16mm	118-1947	118-1919

Application notes

Provision for PE Grounding is located at the PE Stamp on the compressor

Model

Designation	KLF4.8CNDS	220-240V/50Hz	Conf. 1	Sales code:	106H2503
-------------	-------------------	----------------------	----------------	-------------	-----------------

Configuration

Motorconfiguration	CSIR
Power supply (nominal)	220-240V/50Hz 1~
Refrigerant	R290
Application	LBP+MBP
Voltage range	198-254V
Starting torque	HST
Approvals	VDE CCC

Electrical accessories / wiring diagram

CSIR



Ambient/ machine room temperatures minimum /maximum

Ambient temperature range:	10 - 43°C / 50 - 110°F
Machine room temperature range:	10 - 48°C / 50 - 119°F
Compressor cooling:	fan 3m/s

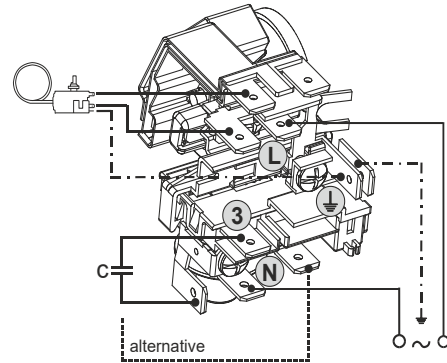

Operation pressure range

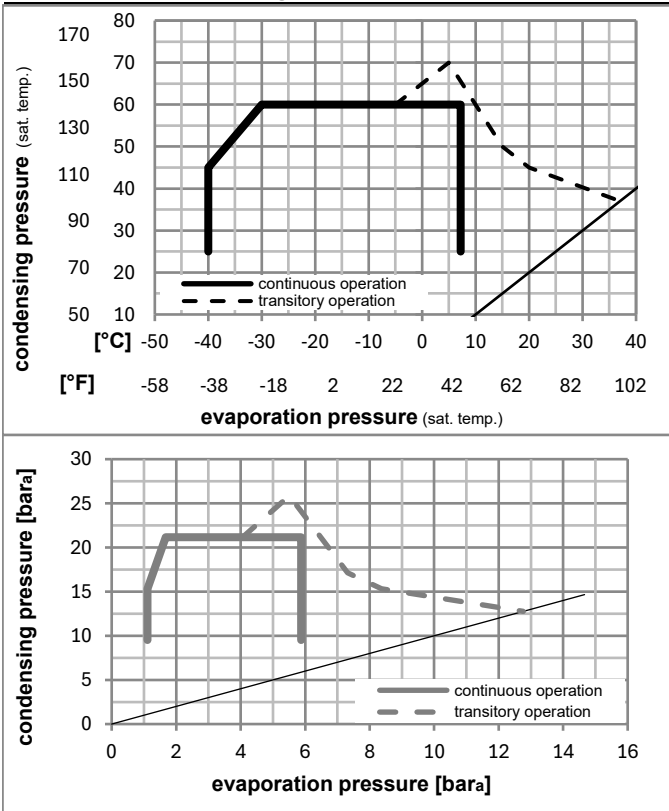

Components

a5	current relay (T1189/L6-S3)	117U7073
c	start capacitor (80µF, 6.3mm)	117U5001
b, d	cover + clamp + screws(5VA) in bag	103N1060

Alternative components

b, d	100x cover + clamp + screws(5VA)	103N2060
b, d	cover + clamp + screws(5VA-compl.)	103N0600

Model

Designation **KLF4.8CNDS** **220-240V/50Hz** Conf. 1 Sales code: **106H2503**

Optimization + standard conditions

R290, 220V/50Hz, CSIR, fan 3m/s, VDE, CCC

	Evaporating pressure (saturation temperature)				Condensing pressure (saturation temperature)			Return gas temp.	Liquid temp.	Cooling capacity	COP	EER	Power consumption			Ref. mass flow
	pe	pc	RGT	Tliq	[W]	[Btu/h]	[kcal/h]						P1	I	m	
	[°C]	[°F]	[°C]	[°F]	[W]	[Btu/h]	[kcal/h]	[W/W]	[Btu/Wh]	[kcal/Wh]	[W]	[A]	[kg/h]			
ASHRAE LBP	-23	54	32	32	222,0	758	191,0	1,46	4,99	1,26	151,9	1,06	2,25			
	-10	130	90	90												
cecomaf LBP	-25	55	32	55	165,4	565	142,4	1,12	3,83	0,97	147,3	1,05	2,06			
	-13	131	90	131												
EN12900 LBP	-35	40	20	40	122,4	418	105,3	1,04	3,57	0,90	117,1	0,97	1,40			
	-31	104	68	104												
ASHRAE MBP	-7	54	35	46	395,9	1352	340,7	2,01	6,88	1,73	196,7	1,21	4,52			
	20	130	95	115												
cecomaf MBP	-10	55	32	55	314,6	1074	270,7	1,66	5,68	1,43	189,2	1,19	3,98			
	14	131	90	131												
EN12900 MBP	-10	45	20	45	354,9	1212	305,4	2,08	7,09	1,79	170,9	1,12	4,36			
	14	113	68	113												

Performance tables

R290, 220V/50Hz, CSIR, fan 3m/s, VDE, CCC

	pe		Cooling capacity			COP	EER	P1	I	m	
	[°C]	[°F]	[W]	[Btu/h]	[kcal/h]	[W/W]	[Btu/Wh]	[kcal/Wh]	[W]	[A]	[kg/h]
[°C / °F]	-40	-40	75,9	259	65,3	0,71	2,43	0,61	106,6	0,95	0,85
cond. pressure	-35	-31	114,8	392	98,8	0,97	3,30	0,83	118,8	0,97	1,29
pc= 45/113	-25	-13	199,8	682	171,9	1,41	4,82	1,22	141,5	1,03	2,25
return gas temp.	-15	5	305,1	1042	262,5	1,89	6,44	1,62	161,7	1,09	3,47
RGT= 32/90	-5	23	443,8	1516	381,9	2,47	8,44	2,13	179,5	1,15	5,11
liquid temp	0	32	529,7	1809	455,9	2,83	9,65	2,43	187,4	1,18	6,14
Tliq= 45/113	7,2	45	677,2	2313	582,8	3,43	11,70	2,95	197,6	1,22	7,96
[°C / °F]	-40	-40	50,1	171	43,1	0,49	1,69	0,42	101,4	0,93	0,62
cond. pressure	-35	-31	87,5	299	75,3	0,75	2,55	0,64	117,2	0,97	1,08
pc= 55/131	-25	-13	165,4	565	142,4	1,12	3,83	0,97	147,3	1,05	2,06
return gas temp	-15	5	258,4	882	222,4	1,47	5,02	1,27	175,7	1,14	3,25
RGT= 32/90	-5	23	379,5	1296	326,6	1,88	6,41	1,62	202,2	1,23	4,83
liquid temp	0	32	454,6	1553	391,2	2,12	7,23	1,82	214,7	1,28	5,84
Tliq= 55/131	7,2	45	584,2	1995	502,7	2,52	8,61	2,17	231,7	1,34	7,61