

Model

Designation	KLF4.8CNH	115-127V/60Hz 1~	Sales code:	106H3500
-------------	------------------	------------------	-------------	-----------------

Compressor design

Oil type	Polyolester	Refrigerant(s)	R290
Oil viscosity	10,4cSt	Displacement	4,8cm ³ / 0,29cu.in
Oil quantity	174cm ³ / 5,9fl.oz	Compressors on pallet	100
Refr. charge - tech. limit	200g / 7,1oz		
Free gas volume comp.	1615cm ³ / 54,6fl.oz		
Weight	9,4kg / 20,7lbs		
Motor protection	external		
Winding resistance main	2Ω (at 25°C)		
Winding resistance aux	8,5Ω (at 25°C)		
Max. winding temp.	125°C / 257°F		
Max. discharge temp.	130°C / 266°F		



General - Configurations with KLF4.8CNH

	Conf. 1	Conf. 2
Motorconfiguration	CSIR	RSCR
Power supply (nominal)	115-127V/60Hz	115-127V/60Hz
Number of phases	1	1
Voltage range	95-140V	95-140V
Approvals	UL, CCC	UL, CCC
Starting torque	HST	LST
Note	- / -	

Applications with KLF4.8CNH

	Conf. 1	Conf. 2
Refrigerant	R290	R290
Application	LBP+MBP	LBP+MBP
System cooling	fan 3m/s	fan 3m/s
Hot gas defrost	OK	OK
Long interval pull down	OK	OK

Electrical data - Configurations with KLF4.8CNH

	Conf. 1	Conf. 2
Starting device type	relay	PTC
Run capacitor	-/-	15μF
Start capacitor	240μF	-/-
LRA (locked rotor amps / 4s/ U(N))	29,8A	29,8A
RLA (rated load amps / 1s/ U(N))	4,3A	4,3A
Cut in current (U(N))	27,5A	30,1A

Model

Designation	KLF4.8CNH	115-127V/60Hz 1~	Sales code:	106H3500
-------------	------------------	------------------	-------------	-----------------

Compressor dimensions

Housing	A Height	182mm / 7,17in
	B Height	175mm / 6,89in
	C Length shell	198mm / 7,8in
	D Length w. cover	238mm / 9,37in
	E Width	160mm / 6,3in

Connectors		Suction	Discharge	Process
		X	Y	Z
Diameter	[mm]	øi 8,11-8,29	øi 6,41-6,59	øi 6,41-6,59
(i:inside, o:outside)	[in]	øi 0,32-0,33	øi 0,25-0,26	øi 0,25-0,26
Material		copper	copper	copper
Horizontal angle	±2°	35°	13°	0°
Vertical angle	±2°	30°	40°	145°
Position l/h/w	[mm]	119/73/59	117/107/66	-88/101/71
	[in]	4,7/2,9/2,3	4,6/4,2/2,6	-3,5/4/2,8
Straight tube l.	[mm]	14	14	14
	[in]	0,5	0,5	0,5

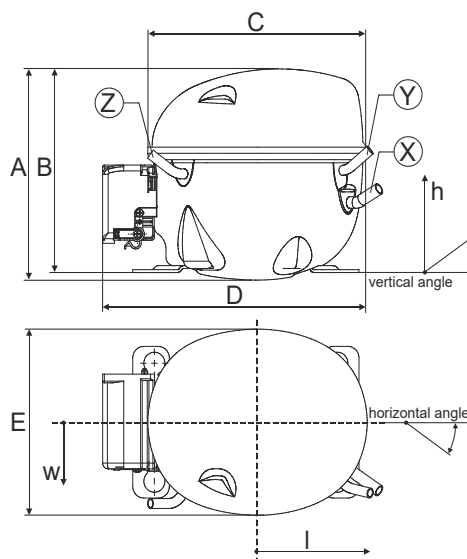

Compressor fixation

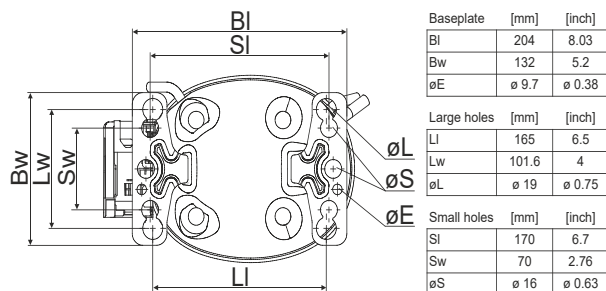

Bolt joint



Snap-on

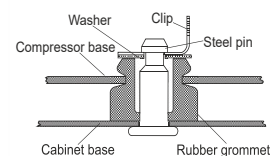

Mounting accessories

	one comp.	multi pack
Bolt joint M6 ø16mm	118-1917	118-1918
Bolt joint ø1/4" ø16mm	118-1946	
Bolt joint ø1/4" ø19mm	118-1949	
Snap-on ø7,3 ø16mm	118-1947	118-1919

Application notes

Provision for PE Grounding is located at the PE Stamp on the compressor

Model

Designation	KLF4.8CNH	115-127V/60Hz	Conf. 1	Sales code:	106H3500
-------------	------------------	----------------------	----------------	-------------	-----------------

Configuration

Motorconfiguration	CSIR
Power supply (nominal)	115-127V/60Hz 1~
Refrigerant	R290
Application	LBP+MBP
Voltage range	95-140V
Starting torque	HST
Approvals	UL CCC

Electrical accessories / wiring diagram

CSIR



Ambient/ machine room temperatures minimum /maximum

Ambient temperature range:	10 - 43°C / 50 - 110°F
Machine room temperature range:	10 - 48°C / 50 - 119°F
Compressor cooling:	fan 3m/s

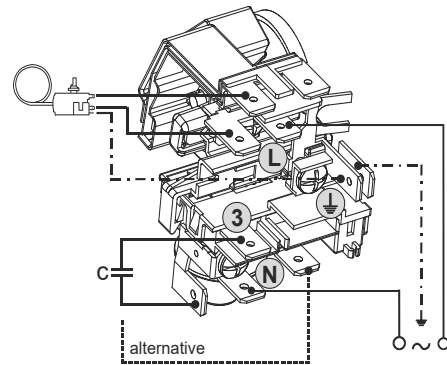

Operation pressure range

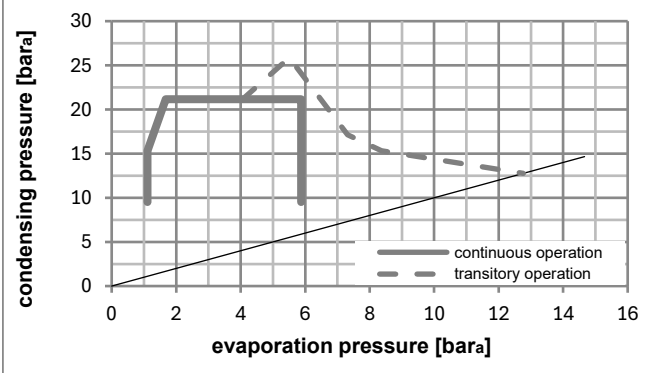
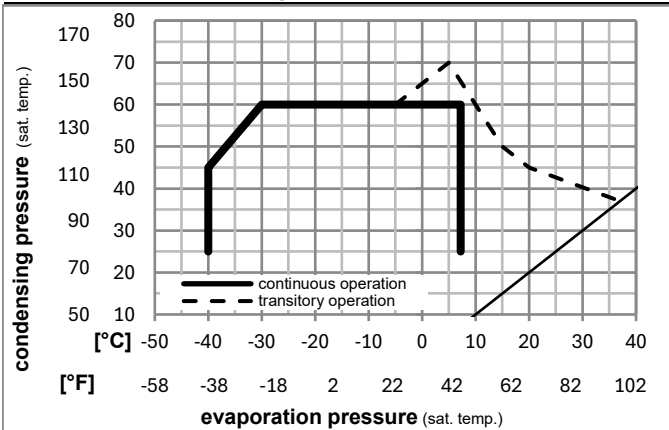

Components

a5	current relay (T1217/L6-S5)	117U7072
c	start capacitor (240µF)	117U5002
b, d	cover + clamp + screws(5VA) in bag	103N1060

Alternative components

b, d	100x cover + clamp + screws(5VA)	103N2060
b, d	cover + clamp + screws(5VA-compl.)	103N0600

Model

Designation **KLF4.8CNH** **115-127V/60Hz** Conf. 1 Sales code: **106H3500**

Optimization + standard conditions

R290, 115V/60Hz, CSIR, fan 3m/s, UL, CCC

	Evaporating pressure (saturation temperature)				Cooling capacity			COP	EER	P1	Power consumption		ASHRAE LBP	
	pe	pc	RGT	Tliq	[W]	[Btu/h]	[kcal/h]				I	m		
	[°C]	[°F]	[°C]	[°F]	[W]	[Btu/h]	[kcal/h]	[W/W]	[Btu/Wh]	[kcal/Wh]	[W]	[A]	[kg/h]	
	-23	54	32	32	278,1	950	239,3	1,55	5,31	1,34	178,9	2,78	2,82	ASHRAE LBP
	-10	130	90	90										
	-25	55	32	55	208,0	710	179,0	1,21	4,13	1,04	172,0	2,75	2,59	cecomaf LBP
	-13	131	90	131										
	-35	40	20	40	156,7	535	134,9	1,17	4,00	1,01	133,8	2,61	1,79	EN12900 LBP
	-31	104	68	104										
	-7	54	35	46	508,0	1735	437,2	2,07	7,07	1,78	245,4	3,16	5,80	ASHRAE MBP
	20	130	95	115										
	-10	55	32	55	401,5	1371	345,6	1,72	5,87	1,48	233,7	3,09	5,08	cecomaf MBP
	14	131	90	131										
	-10	45	20	45	452,0	1544	389,0	2,06	7,05	1,78	219,0	2,99	5,55	EN12900 MBP
	14	113	68	113										

Performance tables

R290, 115V/60Hz, CSIR, fan 3m/s, UL, CCC

	pe		Cooling capacity			COP	EER	P1	I	m	
	[°C]	[°F]	[W]	[Btu/h]	[kcal/h]						
[°C / °F]	-40	-40	113,5	388	97,7	0,96	3,27	0,82	118,6	2,57	1,27
cond. pressure	-34	-30	153,7	525	132,3	1,12	3,84	0,97	136,6	2,62	1,72
pc= 45/113	-23	-10	267,3	913	230,1	1,53	5,21	1,31	175,2	2,77	3,02
return gas temp.	-15	5	385,1	1315	331,4	1,89	6,46	1,63	203,5	2,91	4,38
RGT= 32/90	-4	25	591,1	2019	508,7	2,51	8,58	2,16	235,3	3,09	6,82
liquid temp	0	32	677,5	2314	583,1	2,78	9,49	2,39	243,9	3,14	7,86
Tliq= 45/113	7,2	45	859,4	2935	739,6	3,37	11,52	2,90	254,8	3,22	10,10
[°C / °F]	-40	-40	99,2	339	85,4	0,88	2,99	0,75	113,2	2,54	1,22
cond. pressure	-34	-30	130,7	446	112,5	0,98	3,34	0,84	133,7	2,60	1,62
pc= 55/131	-23	-10	225,0	768	193,6	1,26	4,29	1,08	179,0	2,78	2,81
return gas temp	-15	5	326,6	1115	281,0	1,53	5,22	1,31	213,8	2,97	4,11
RGT= 32/90	-4	25	508,6	1737	437,7	1,98	6,78	1,71	256,2	3,23	6,49
liquid temp	0	32	586,0	2001	504,3	2,18	7,44	1,87	269,0	3,31	7,53
Tliq= 55/131	7,2	45	750,2	2562	645,7	2,60	8,88	2,24	288,6	3,45	9,77

Model

Designation	KLF4.8CNH	115-127V/60Hz	Conf. 2	Sales code:	106H3500
-------------	------------------	----------------------	----------------	-------------	-----------------

Configuration

Motor configuration	RSCR
Power supply (nominal)	115-127V/60Hz 1~
Refrigerant	R290
Application	LBP+MBP
Voltage range	95-140V
Starting torque	LST
Approvals	UL CCC

Electrical accessories / wiring diagram

RSCR

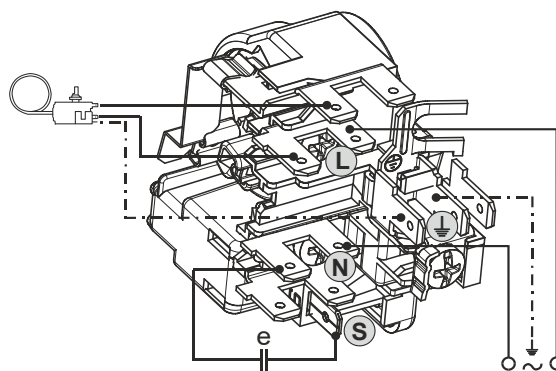
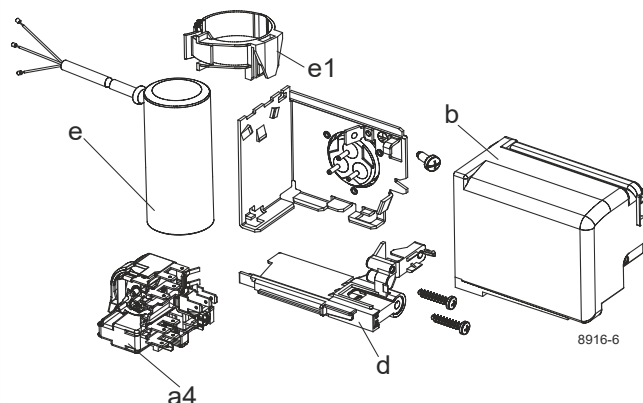

Ambient/ machine room temperatures minimum /maximum

Ambient temperature range: 10 - 43°C / 50 - 110°F

Machine room temperature range: 10 - 48°C / 50 - 119°F

Compressor cooling: fan 3m/s

Operation pressure range

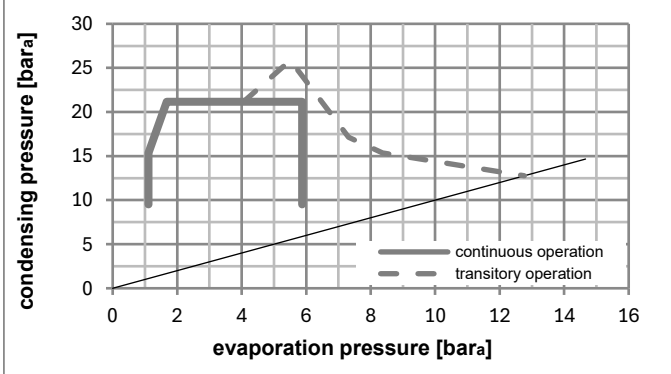
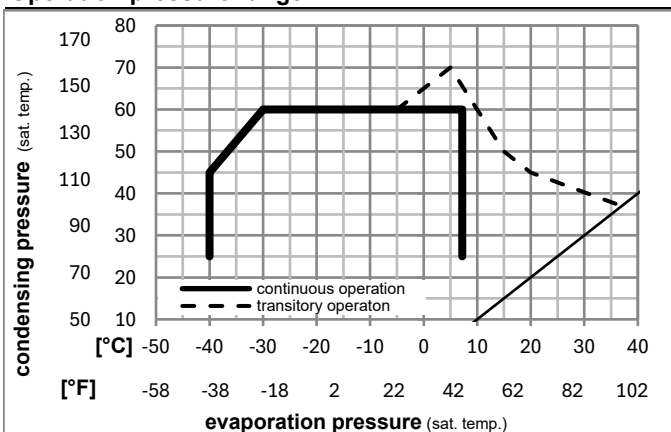

Components

a4	DLS5 (PTC,6.3mm, T1217/L6 - S5)	103N0212
e	run capacitor (15μF, 6,3mm)	117-7153
b, d	cover + clamp + screws(5VA) in bag	103N1060
e1	retaining clamp	103N0535

Alternative components

b, d	100x cover + clamp + screws(5VA)	103N2060
b, d	cover + clamp + screws(5VA-compl.)	103N0600

Model

Designation **KLF4.8CNH** **115-127V/60Hz** Conf. 2 Sales code: **106H3500**

Optimization + standard conditions

R290, 115V/60Hz, RSCR, fan 3m/s, UL, CCC

	Evaporating pressure (saturation temperature)				Condensing pressure (saturation temperature)			Return gas temp.	Liquid temp.	Cooling capacity	COP	EER	Power consumption			Ref. mass flow
	pe	pc	RGT	Tliq	[W]	[Btu/h]	[kcal/h]						P1	I	m	
	[°C]	[°F]	[°C]	[°F]	[W]	[Btu/h]	[kcal/h]	[W/W]	[Btu/Wh]	[kcal/Wh]	[W]	[A]	[kg/h]			
ASHRAE LBP	-23	54	32	32	278,7	952	239,9	1,61	5,51	1,39	172,7	2,80	2,82			
	-10	130	90	90												
cecomaf LBP	-25	55	32	55	208,5	712	179,4	1,26	4,29	1,08	166,0	2,77	2,60			
	-13	131	90	131												
EN12900 LBP	-35	40	20	40	157,1	537	135,2	1,22	4,15	1,05	129,1	2,62	1,80			
	-31	104	68	104												
ASHRAE MBP	-7	54	35	46	509,2	1739	438,2	2,15	7,34	1,85	236,8	3,17	5,81			
	20	130	95	115												
cecomaf MBP	-10	55	32	55	402,5	1375	346,4	1,78	6,09	1,54	225,6	3,10	5,09			
	14	131	90	131												
EN12900 MBP	-10	45	20	45	453,1	1547	389,9	2,14	7,32	1,85	211,3	3,01	5,56			
	14	113	68	113												

Performance tables

R290, 115V/60Hz, RSCR, fan 3m/s, UL, CCC

	pe		Cooling capacity			COP	EER	P1	I	m	
	[°C]	[°F]	[W]	[Btu/h]	[kcal/h]	[W/W]	[Btu/Wh]				[kcal/Wh]
[°C / °F]	-40	-40	113,8	389	97,9	0,99	3,39	0,86	114,5	2,59	1,27
cond. pressure	-34	-30	154,0	526	132,6	1,17	3,99	1,01	131,8	2,63	1,73
pc= 45/113	-23	-10	268,0	915	230,6	1,58	5,41	1,36	169,1	2,78	3,03
return gas temp.	-15	5	386,0	1318	332,2	1,97	6,71	1,69	196,4	2,92	4,39
RGT= 32/90	-4	25	592,5	2024	509,9	2,61	8,91	2,25	227,1	3,11	6,83
liquid temp	0	32	679,2	2319	584,5	2,89	9,86	2,48	235,3	3,16	7,88
Tliq= 45/113	7,2	45	861,4	2942	741,3	3,50	11,97	3,02	245,9	3,23	10,12
[°C / °F]	-40	-40	99,4	340	85,6	0,91	3,11	0,78	109,2	2,55	1,23
cond. pressure	-34	-30	131,0	447	112,7	1,02	3,47	0,87	129,0	2,61	1,62
pc= 55/131	-23	-10	225,5	770	194,1	1,31	4,46	1,12	172,7	2,80	2,81
return gas temp	-15	5	327,3	1118	281,7	1,59	5,42	1,37	206,3	2,98	4,12
RGT= 32/90	-4	25	509,8	1741	438,7	2,06	7,04	1,77	247,3	3,24	6,51
liquid temp	0	32	587,4	2006	505,6	2,26	7,73	1,95	259,6	3,33	7,55
Tliq= 55/131	7,2	45	752,1	2568	647,2	2,70	9,22	2,32	278,5	3,46	9,80