

Model

Designation	KLF4.8CNHS	115-127V/60Hz 1~	Sales code:	106H3503
-------------	-------------------	------------------	-------------	-----------------

Compressor design

Oil type	Polyolester	Refrigerant(s)	R290
Oil viscosity	9,7cST	Displacement	4,8cm ³ / 0,29cu.in
Oil quantity	170cm ³ / 5,7fl.oz	Compressors on pallet	100
Refr. charge - tech. limit	200g / 7,1oz		
Free gas volume comp.	1615cm ³ / 54,6fl.oz		
Weight	9,4kg / 20,7lbs		
Motor protection	external		
Winding resistance main	2Ω (at 25°C)		
Winding resistance aux	8,5Ω (at 25°C)		
Max. winding temp.	125°C / 257°F		
Max. discharge temp.	130°C / 266°F		
Additional note	Very good robustness against liquid intake. Ice-cube maker optimization - indirect suction intake.		



General - Configurations with KLF4.8CNHS

	Conf. 1
Motorconfiguration	CSIR
Power supply (nominal)	115-127V/60Hz
Number of phases	1
Voltage range	95-140V
Approvals	UL, CCC
Starting torque	HST
Note	LRA value on compressor label and datasheet may differ due to different test conditions for UL approval.

Applications with KLF4.8CNHS

	Conf. 1
Refrigerant	R290
Application	LBP+MBP
System cooling	fan 3m/s
Hot gas defrost	OK
Long interval pull down	OK

Electrical data - Configurations with KLF4.8CNHS

	Conf. 1
Starting device type	relay
Run capacitor	-/-
Start capacitor	240μF
LRA (locked rotor amps / 4s)	27,5A
RLA (rated load amps / 1s)	4,3A
Cut in current	27,5A

Model

Designation

KLF4.8CNHS

115-127V/60Hz 1~

Sales code:

106H3503

Compressor dimensions

Housing	A Height	182mm / 7,17in
	B Height	175mm / 6,89in
	C Length shell	198mm / 7,8in
	D Length w. cover	238mm / 9,37in
	E Width	160mm / 6,3in

Connectors		Suction	Discharge	Process
		X	Y	Z
Diameter	[mm]	øi 8,11-8,29	øi 6,41-6,59	øi 6,41-6,59
	(i:inside, o:outside) [in]	øi 0,32-0,33	øi 0,25-0,26	øi 0,25-0,26
Material		copper	copper	copper
Horizontal angle	±2°	35°	13°	0°
Vertical angle	±2°	30°	40°	145°
Position l/h/w	[mm]	120/72/57	112/106/81	-97/94/72
	[in]	4,7/2,8/2,2	4,4/4,2/3,2	-3,8/3,7/2,8
Straight tube l.	[mm]	14	14	14
	[in]	0,5	0,5	0,5

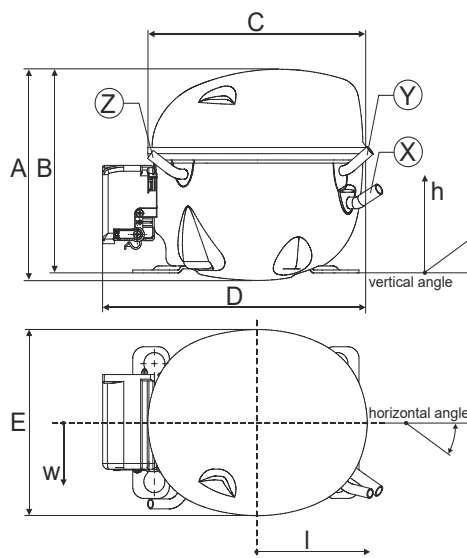

Compressor fixation

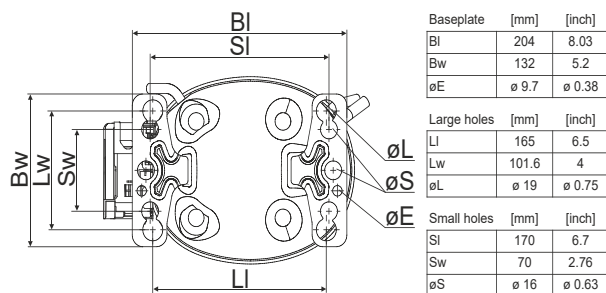

Bolt joint



Snap-on



Mounting accessories

	one comp.	multi pack
Bolt joint M6 ø16mm	118-1917	118-1918
Bolt joint ø1/4" ø16mm	118-1946	
Bolt joint ø1/4" ø19mm	118-1949	
Snap-on ø7,3 ø16mm	118-1947	118-1919

Application notes

Provision for PE Grounding is located at the PE Stamp on the compressor

Model

Designation	KLF4.8CNHS	115-127V/60Hz	Conf. 1	Sales code:	106H3503
-------------	-------------------	----------------------	---------	-------------	-----------------

Configuration

Motorconfiguration	CSIR
Power supply (nominal)	115-127V/60Hz 1~
Refrigerant	R290
Application	LBP+MBP
Voltage range	95-140V
Starting torque	HST
Approvals	UL
	CCC

Electrical accessories / wiring diagram

CSIR

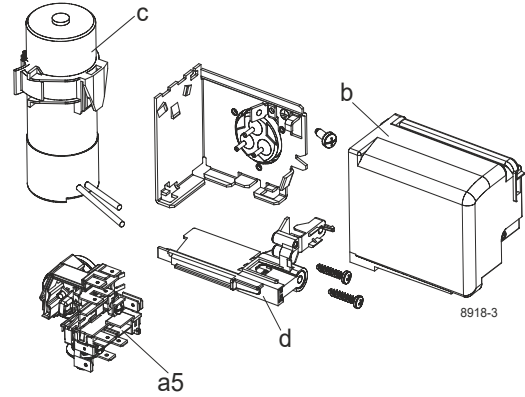

Ambient/ machine room temperatures minimum /maximum

Ambient temperature range: 10 - 43°C / 50 - 110°F

Machine room temperature range: 10 - 48°C / 50 - 119°F

Compressor cooling: fan 3m/s

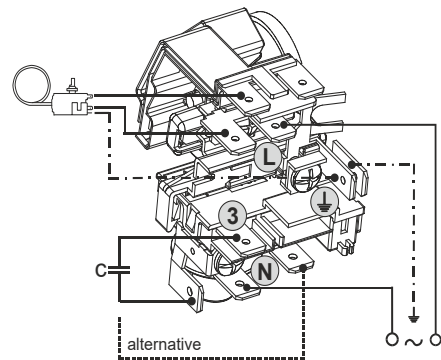

Operation pressure range

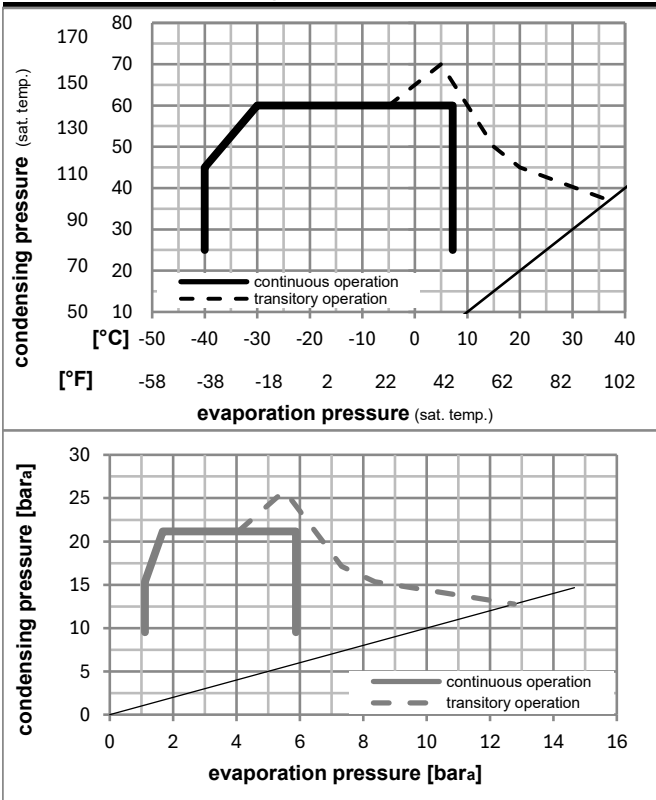

Components

a5	current relay (T1217/L6-S5)	117U7072
c	start capacitor (240µF)	117U5002
b, d	cover + clamp + screws(5VA) in bag	103N1060

Alternative components

b, d	cover + clamp + screws(5VA-compl.)	103N0600
------	------------------------------------	----------

Model

Designation **KLF4.8CNHS** **115-127V/60Hz** Conf. 1 Sales code: **106H3503**

Optimization + standard conditions

R290, 115V/60Hz, CSIR, fan 3m/s, UL, CCC

	Evaporating pressure (saturation temperature)				Cooling capacity			COP	EER	P1	Power consumption		ASHRAE LBP	
	pe	pc	RGT	Tliq	[W]	[Btu/h]	[kcal/h]				I	m		
[°C]	-23	54	32	32	268,3	916	230,9	1,52	5,18	1,30	177,0	2,76	2,72	
[°F]	-10	130	90	90										
[°C]	-25	55	32	55	200,7	686	172,7	1,18	4,03	1,01	170,2	2,72	2,50	cecomaf LBP
[°F]	-13	131	90	131										
[°C]	-35	40	20	40	151,3	517	130,2	1,14	3,90	0,98	132,4	2,58	1,73	EN12900 LBP
[°F]	-31	104	68	104										
[°C]	-7	54	35	46	490,3	1674	421,9	2,02	6,89	1,74	242,8	3,12	5,59	ASHRAE MBP
[°F]	20	130	95	115										
[°C]	-10	55	32	55	387,5	1323	333,5	1,68	5,72	1,44	231,3	3,05	4,90	cecomaf MBP
[°F]	14	131	90	131										
[°C]	-10	45	20	45	436,2	1490	375,4	2,01	6,87	1,73	216,7	2,96	5,36	EN12900 MBP
[°F]	14	113	68	113										

Performance tables

R290, 115V/60Hz, CSIR, fan 3m/s, UL, CCC

	pe		Cooling capacity			COP	EER		P1	I	m
	[°C]	[°F]	[W]	[Btu/h]	[kcal/h]		[Btu/Wh]	[kcal/Wh]			
[°C / °F]	-40	-40	109,5	374	94,3	0,93	3,19	0,80	117,4	2,54	1,22
cond. pressure	-34	-30	148,3	506	127,6	1,10	3,75	0,94	135,2	2,59	1,66
pc= 45/113	-23	-10	258,0	881	222,0	1,49	5,08	1,28	173,4	2,74	2,91
return gas temp.	-15	5	371,6	1269	319,8	1,85	6,30	1,59	201,4	2,88	4,23
RGT= 32/90	-4	25	570,4	1948	490,9	2,45	8,37	2,11	232,9	3,06	6,58
liquid temp	0	32	653,9	2233	562,7	2,71	9,25	2,33	241,3	3,11	7,58
Tliq= 45/113	7,2	45	829,3	2832	713,7	3,29	11,24	2,83	252,1	3,18	9,74
[°C / °F]	-40	-40	95,7	327	82,4	0,85	2,92	0,74	112,0	2,51	1,18
cond. pressure	-34	-30	126,1	431	108,5	0,95	3,26	0,82	132,3	2,57	1,56
pc= 55/131	-23	-10	217,1	742	186,9	1,23	4,19	1,06	177,1	2,76	2,71
return gas temp	-15	5	315,1	1076	271,2	1,49	5,09	1,28	211,5	2,94	3,96
RGT= 32/90	-4	25	490,8	1676	422,4	1,94	6,61	1,67	253,6	3,19	6,26
liquid temp	0	32	565,5	1931	486,7	2,12	7,26	1,83	266,2	3,28	7,26
Tliq= 55/131	7,2	45	724,0	2473	623,1	2,54	8,66	2,18	285,5	3,41	9,43