

## Model

Designation	<b>KLF4.8CNHS</b>	115-127V/60Hz 1~	Sales code:	<b>106H3513</b>
-------------	-------------------	------------------	-------------	-----------------

## Compressor design

Oil type	Polyolester	Refrigerant(s)	<b>R290</b>
Oil viscosity	10,4cSt	Displacement	4,8cm <sup>3</sup> / 0,29cu.in
Oil quantity	170cm <sup>3</sup> / 5,7fl.oz	Compressors on pallet	100
Refr. charge - tech. limit	200g / 7,1oz		
Free gas volume comp.	1615cm <sup>3</sup> / 54,6fl.oz		
Weight	9,4kg / 20,7lbs		
Motor protection	external		
Winding resistance main	2Ω (at 25°C)		
Winding resistance aux	8,5Ω (at 25°C)		
Max. winding temp.	125°C / 257°F		
Max. discharge temp.	130°C / 266°F		
Additional note	Very good robustness against liquid intake. Ice-cube maker optimization - indirect suction intake.		



## General - Configurations with KLF4.8CNHS

	<b>Conf. 1</b>
Motorconfiguration	CSIR
Power supply (nominal)	115-127V/60Hz
Number of phases	1
Voltage range	95-140V
Approvals	UL, CCC
Starting torque	HST
Note	Electrical equipment is included and pre-assembled to compressor.

## Applications with KLF4.8CNHS

	<b>Conf. 1</b>
Refrigerant	R290
Application	LBP+MBP
System cooling	fan 3m/s
Hot gas defrost	OK
Long interval pull down	OK

## Electrical data - Configurations with KLF4.8CNHS

	<b>Conf. 1</b>
Starting device type	relay
Run capacitor	-/-
Start capacitor	240μF
LRA (locked rotor amps / 4s/ U(N))	29,8A
RLA (rated load amps / 1s/ U(N))	4,3A
Cut in current (U(N))	27,5A

## Model

Designation

**KLF4.8CNHS**

115-127V/60Hz 1~

Sales code:

**106H3513**

## Compressor dimensions

Housing	A Height	182mm / 7,17in
	B Height	175mm / 6,89in
	C Length shell	198mm / 7,8in
	D Length w. cover	238mm / 9,37in
	E Width	160mm / 6,3in

Connectors		Suction	Discharge	Process
		X	Y	Z
Diameter	[mm]	øi 8,11-8,29	øi 6,41-6,59	øi 6,41-6,59
(i:inside, o:outside)	[in]	øi 0,32-0,33	øi 0,25-0,26	øi 0,25-0,26
Material		copper	copper	copper
Horizontal angle	±2°	35°	13°	0°
Vertical angle	±2°	30°	40°	145°
Position l/h/w	[mm]	119/73/59	117/107/66	-88/101/71
	[in]	4,7/2,9/2,3	4,6/4,2/2,6	-3,5/4/2,8
Straight tube l.	[mm]	14	14	14
	[in]	0,5	0,5	0,5

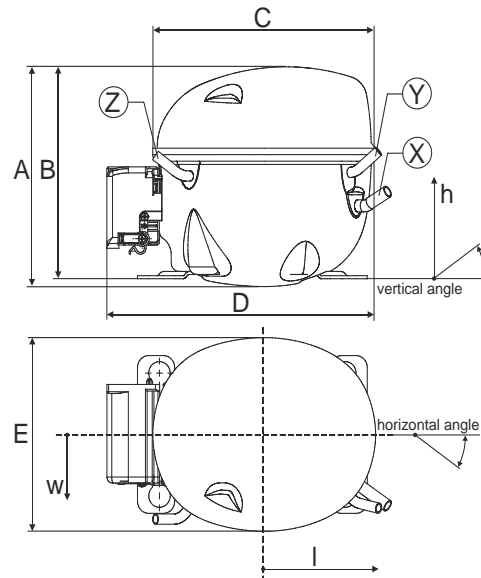

## Compressor fixation

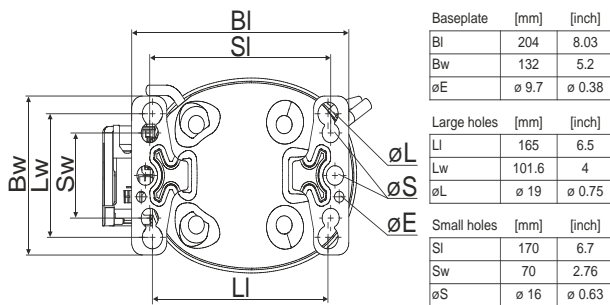

### Bolt joint

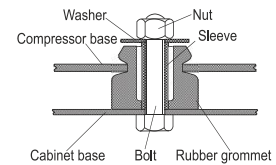

### Snap-on

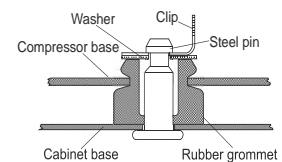

Mounting accessories	one comp.	multi pack
Bolt joint   M6   ø16mm	118-1917	118-1918
Bolt joint   ø1/4"   ø16mm	118-1946	
Bolt joint   ø1/4"   ø19mm	118-1949	
Snap-on   ø7,3   ø16mm	118-1947	118-1919

## Application notes

Provision for PE Grounding is located at the PE Stamp on the compressor

## Model

Designation **KLF4.8CNHS** **115-127V/60Hz** Conf. 1 Sales code: **106H3513**

## Configuration

Motorconfiguration CSIR  
 Power supply (nominal) 115-127V/60Hz 1~  
 Refrigerant R290  
 Application LBP+MBP  
 Voltage range 95-140V  
 Starting torque HST  
 Approvals UL  
 CCC

## Electrical accessories / wiring diagram

CSIR

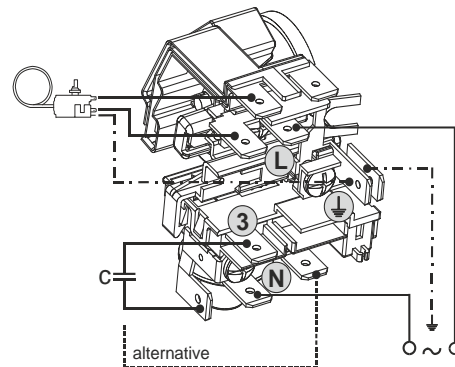

## Ambient/ machine room temperatures minimum /maximum

Ambient temperature range: 10 - 43°C / 50 - 110°F

Machine room temperature range: 10 - 48°C / 50 - 119°F

Compressor cooling: fan 3m/s

## Operation pressure range

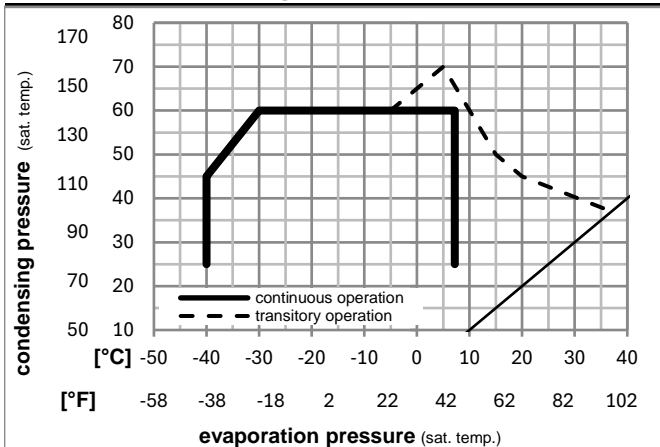

## Components (incl. and pre. assembl.)

a5	current relay (T1217/L6-S5)	117U7072
c	start capacitor (240µF)	117U5002
b, d	cover + clamp + screws(5VA-compl.)	103N0600

## Alternative comp.

b, d	100x cover + clamp + screws(5VA)	103N2060
b, d	cover + clamp + screws(5VA) in bag	103N1060

