

Model

Designation	KLF4.8CNT	200-240V/50Hz 1~ 208-230V/60Hz 1~	Sales code:	106H2507
-------------	------------------	-----------------------------------	-------------	-----------------

Compressor design

Oil type	Polyolester	Refrigerant(s)	R290
Oil viscosity	19,2cST	Displacement	4,8cm ³ / 0,29cu.in
Oil quantity	162cm ³ / 5,5fl.oz	Compressors on pallet	100
Refr. charge - tech. limit	200g / 7,1oz		
Free gas volume comp.	1615cm ³ / 54,6fl.oz		
Weight	9,2kg / 20,3lbs		
Motor protection	external		
Winding resistance main	10,7Ω (at 25°C)		
Winding resistance aux	17Ω (at 25°C)		
Max. winding temp.	125°C / 257°F		
Max. discharge temp.	130°C / 266°F		



General - Configurations with KLF4.8CNT

	Conf. 1	Conf. 2	Conf. 3	Conf. 4
Motorconfiguration	CSIR	RSCR	CSIR	RSCR
Power supply (nominal)	200-240V/50Hz	200-240V/50Hz	208-230V/60Hz	208-230V/60Hz
Number of phases	1	1	1	1
Voltage range	187-254V	187-254V	198-253V	198-253V
Approvals	UL, CCC, CB under prep.	UL, CCC, CB under prep.	UL, CCC, CB under prep.	UL, CCC, CB under prep.
Starting torque	HST	LST	HST	LST
Note	Housing with dip-tray fixture (omega bracket).			

Applications with KLF4.8CNT

	Conf. 1	Conf. 2	Conf. 3	Conf. 4
Refrigerant	R290	R290	R290	R290
Application	LBP+MBP	LBP+MBP	LBP+MBP	LBP+MBP
System cooling	fan 3m/s	fan 3m/s	fan 3m/s	fan 3m/s
Hot gas defrost	OK	OK	OK	OK
Long interval pull down	OK	OK	-/-	-/-

Electrical data - Configurations with KLF4.8CNT

	Conf. 1	Conf. 2	Conf. 3	Conf. 4
Starting device type	relay	PTC	relay	PTC
Run capacitor	-/-	5μF	-/-	5μF
Start capacitor	80μF	-/-	80μF	-/-
LRA (locked rotor amps / 4s)	10,7A	8,8A	10,7A	8,8A
RLA (rated load amps / 1s)	1,7A	1,7A	1,7A	1,7A
Cut in current	10,7A	14,7A	10,7A	14,7A

Model

Designation

KLF4.8CNT

200-240V/50Hz 1~ 208-230V/60Hz 1~

Sales code:

106H2507

Compressor dimensions

Housing	A Height	182mm / 7,17in
	B Height	175mm / 6,89in
	C Length shell	198mm / 7,8in
	D Length w. cover	238mm / 9,37in
	E Width	160mm / 6,3in

Connectors	Suction X	Discharge Y	Process Z
Diameter [mm]	øi 8,11-8,29	øi 6,11-6,29	øi 6,11-6,29
(i:inside, o:outside) [in]	øi 0,32-0,33	øi 0,24-0,25	øi 0,24-0,25
Material	copper	copper	copper
Horizontal angle ±2°	35°	13°	0°
Vertical angle ±2°	30°	40°	145°
Position l/h/w [mm]	120/72/62	112/106/62	-97/102/70
[in]	4,7/2,8/2,4	4,4/4,2/2,4	-3,8/4/2,8
Straight tube l. [mm]	14	14	14
[in]	0,5	0,5	0,5

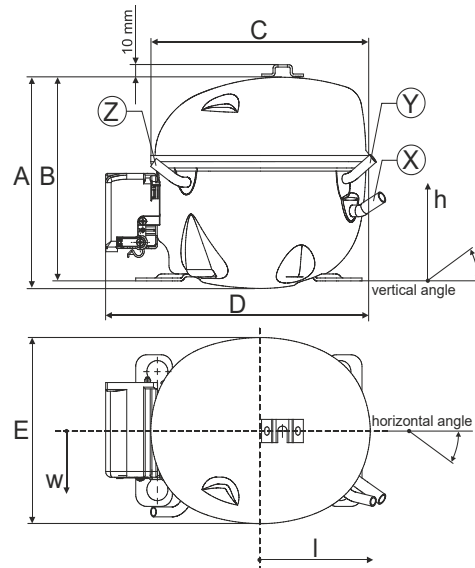

Compressor fixation

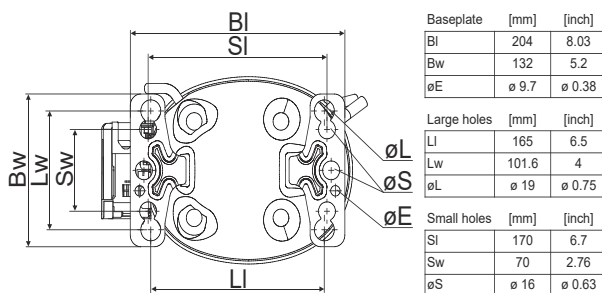

Bolt joint

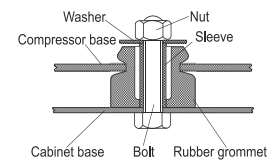

Snap-on

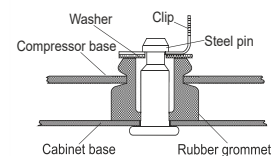

Mounting accessories	one comp.	multi pack
Bolt joint M6 ø16mm	118-1917	118-1918
Bolt joint ø1/4" ø16mm	118-1946	
Bolt joint ø1/4" ø19mm	118-1949	
Snap-on ø7,3 ø16mm	118-1947	118-1919

Application notes

LRA value on compressor label and datasheet may differ due to different test conditions for UL approval.

Provision for PE Grounding is located at the PE Stamp on the compressor

Model

Designation	KLF4.8CNT	200-240V/50Hz	Conf. 1	Sales code:	106H2507
-------------	------------------	----------------------	----------------	-------------	-----------------

Configuration

Motorconfiguration	CSIR
Power supply (nominal)	200-240V/50Hz 1~
Refrigerant	R290
Application	LBP+MBP
Voltage range	187-254V
Starting torque	HST
Approvals	UL
	CCC
	CB under prep.

Electrical accessories / wiring diagram

CSIR

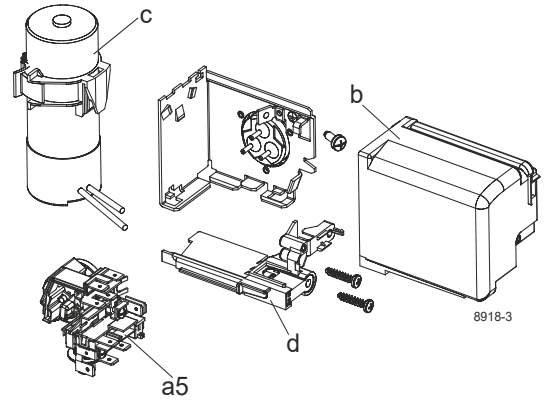

Ambient/ machine room temperatures minimum /maximum

Ambient temperature range:	10 - 43°C / 50 - 110°F
Machine room temperature range:	10 - 48°C / 50 - 119°F

Compressor cooling: fan 3m/s

Compressor with external protector. For max. operation envelope cooling on protector.

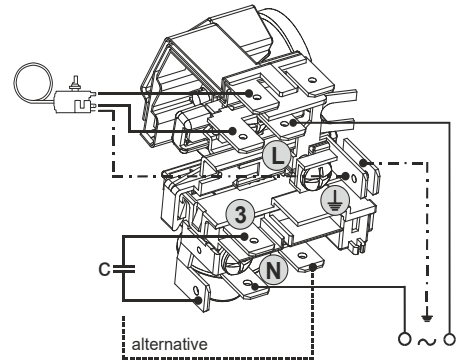
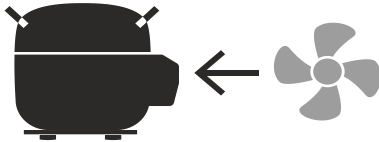

Operation pressure range

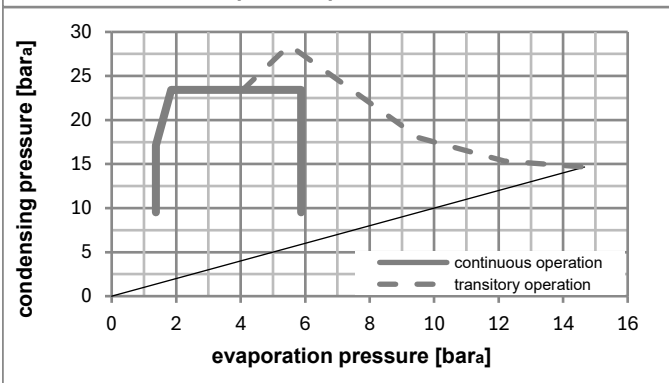
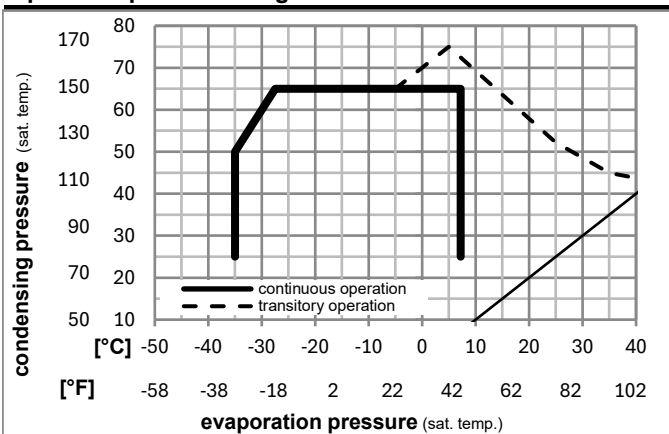

Components

a5	current relay TY (T0089/L6-S2)	117U7070
c	start capacitor (80µF, 6.3mm)	117U5003
b, d	cover + clamp + screws(5VA) in bag	103N1060

Alternative components

b, d	cover + clamp + screws(5VA-compl.)	103N0600
------	------------------------------------	----------

Model

Designation **KLF4.8CNT** **200-240V/50Hz** Conf. 1 Sales code: **106H2507**

Optimization + standard conditions

R290, 220V/50Hz, CSIR, fan 3m/s, UL, CCC, CB under prep.

		Evaporating pressure (saturation temperature)				Condensing pressure (saturation temperature)			Return gas temp.		Liquid temp.		Cooling capacity			COP	EER	Power consumption		
		pe	pc	RGT	Tliq	[W]	[Btu/h]	[kcal/h]	[W/W]	[Btu/Wh]	[kcal/Wh]	P1	I	Current consumption		Ref. mass flow				
[°C]	[°F]	[°C]	[°F]	[°C]	[°F]							[W]	[A]	[A]	[kg/h]					
-23	-10	54	130	32	90	32	90	228,7	781	196,8	1,48	5,05	1,27	154,6	1,38	2,32	ASHRAE LBP			
-25	-13	55	131	32	90	55	131	170,2	581	146,5	1,13	3,87	0,97	150,3	1,37	2,12	cecomaf LBP			
-35	-31	40	104	20	68	40	104	131,9	450	113,5	1,08	3,69	0,93	122,1	1,33	1,51	EN12900 LBP			
-7	20	54	130	35	95	46	115	420,2	1435	361,7	2,07	7,07	1,78	202,9	1,49	4,79	ASHRAE MBP			
-10	14	55	131	32	90	55	131	332,3	1135	286,0	1,71	5,83	1,47	194,6	1,47	4,20	cecomaf MBP			
-10	14	45	113	20	68	45	113	384,6	1314	331,0	2,14	7,29	1,84	180,1	1,43	4,72	EN12900 MBP			

Performance tables

R290, 220V/50Hz, CSIR, fan 3m/s, UL, CCC, CB under prep.

	pe		Cooling capacity			COP	EER	P1	I	m	
	[°C]	[°F]	[W]	[Btu/h]	[kcal/h]	[W/W]	[Btu/Wh]	[kcal/Wh]	[W]	[A]	[kg/h]
[°C / °F]	-35	-31	121,2	414	104,3	0,99	3,37	0,85	122,7	1,33	1,36
cond. pressure	-25	-13	211,4	722	181,9	1,45	4,95	1,25	145,9	1,36	2,38
pc= 45/113	-15	5	328,2	1121	282,5	1,94	6,63	1,67	169,0	1,41	3,73
return gas temp.	-10	14	400,4	1367	344,6	2,22	7,59	1,91	180,1	1,43	4,58
RGT= 32/90	-5	23	483,7	1652	416,3	2,54	8,67	2,19	190,5	1,45	5,57
liquid temp	0	32	579,7	1980	498,9	2,90	9,89	2,49	200,2	1,48	6,72
Tliq= 45/113	7,2	45	743,2	2538	639,6	3,50	11,96	3,01	212,3	1,51	8,73
[°C / °F]	-35	-31	90,2	308	77,6	0,74	2,53	0,64	121,6	1,32	1,12
cond. pressure	-25	-13	170,2	581	146,5	1,13	3,87	0,97	150,3	1,37	2,12
pc= 55/131	-15	5	270,6	924	232,9	1,50	5,14	1,29	179,9	1,43	3,40
return gas temp	-10	14	332,3	1135	286,0	1,71	5,83	1,47	194,6	1,47	4,20
RGT= 32/90	-5	23	403,5	1378	347,3	1,93	6,59	1,66	209,0	1,50	5,14
liquid temp	0	32	485,8	1659	418,1	2,18	7,45	1,88	222,8	1,54	6,24
Tliq= 55/131	7,2	45	626,9	2141	539,5	2,60	8,87	2,24	241,3	1,60	8,17

Model

Designation	KLF4.8CNT	200-240V/50Hz	Conf. 2	Sales code:	106H2507
-------------	------------------	----------------------	----------------	-------------	-----------------

Configuration

Motorconfiguration	RSCR
Power supply (nominal)	200-240V/50Hz 1~
Refrigerant	R290
Application	LBP+MBP
Voltage range	187-254V
Starting torque	LST
Approvals	UL
	CCC
	CB under prep.

Electrical accessories / wiring diagram

RSCR

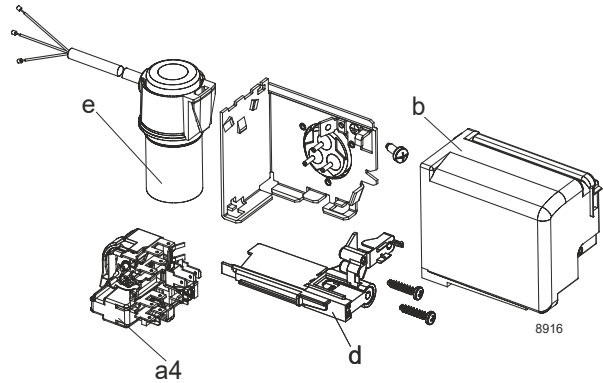

Ambient/ machine room temperatures minimum /maximum

Ambient temperature range:	10 - 43°C / 50 - 110°F
Machine room temperature range:	10 - 48°C / 50 - 119°F

Compressor cooling: fan 3m/s

Compressor with external protector. For max. operation envelope cooling on protector.

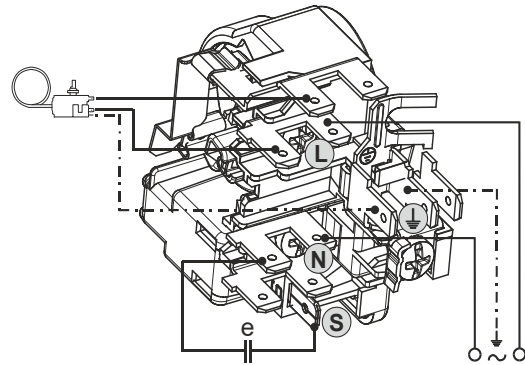
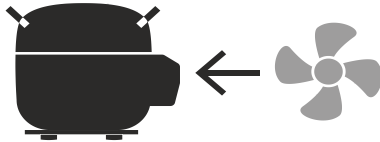

Operation pressure range

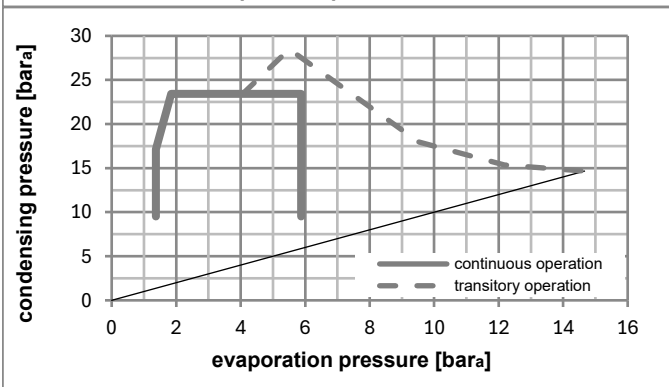
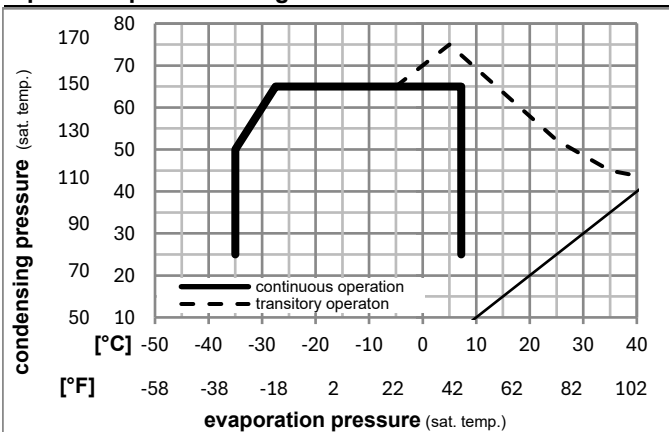

Components

a4	DAS2 (PTC,6.3mm, T0089/L6 - S2)	103N0251
e	run capacitor (5µF, 6,3mm)	117-7155
b, d	cover + clamp + screws(5VA) in bag	103N1060

Alternative components

b, d	cover + clamp + screws(5VA-compl.)	103N0600
------	------------------------------------	----------

Model

Designation	KLF4.8CNT	200-240V/50Hz	Conf. 2	Sales code:	106H2507
-------------	------------------	----------------------	----------------	-------------	-----------------

Optimization + standard conditions

R290, 220V/50Hz, RSCR, fan 3m/s, UL, CCC, CB under prep.

		Evaporating pressure (saturation temperature)				Cooling capacity			COP	EER	Power consumption				
		Condensing pressure (saturation temperature)		Return gas temp.	Liquid temp.	[W]	[Btu/h]	[kcal/h]	[W/W]	[Btu/Wh]	[kcal/Wh]	P1	I	Ref. mass flow	
[°C]	[°F]	pe	pc	RGT	Tliq							[W]	[A]	[kg/h]	
-23	-10	54	130	32	90	232,8	795	200,4	1,54	5,26	1,32	151,2	1,11	2,36	ASHRAE LBP
-25	-13	55	131	32	90	173,6	593	149,4	1,18	4,03	1,01	147,3	1,09	2,16	cecomaf LBP
-35	-31	40	104	20	68	131,0	447	112,7	1,10	3,77	0,95	118,6	1,02	1,50	EN12900 LBP
-7	20	54	130	35	95	420,7	1437	362,1	2,17	7,42	1,87	193,7	1,22	4,80	ASHRAE MBP
-10	14	55	131	32	90	334,0	1141	287,4	1,79	6,11	1,54	186,8	1,20	4,22	cecomaf MBP
-10	14	45	113	20	68	381,6	1303	328,4	2,23	7,61	1,92	171,3	1,16	4,69	EN12900 MBP

Performance tables

R290, 220V/50Hz, RSCR, fan 3m/s, UL, CCC, CB under prep.

	pe		Cooling capacity			COP	EER	P1			I	m
	[°C]	[°F]	[W]	[Btu/h]	[kcal/h]	[W/W]	[Btu/Wh]	[kcal/Wh]	[W]	[A]	[kg/h]	
[°C / °F]	-35	-31	121,0	413	104,1	1,01	3,46	0,87	119,5	1,02	1,36	
cond. pressure	-25	-13	210,7	719	181,3	1,49	5,10	1,28	141,2	1,08	2,38	
pc= 45/113	-15	5	326,0	1113	280,6	2,02	6,89	1,74	161,7	1,14	3,71	
return gas temp.	-10	14	397,2	1357	341,9	2,32	7,92	2,00	171,3	1,16	4,54	
RGT= 32/90	-5	23	479,6	1638	412,7	2,66	9,08	2,29	180,3	1,18	5,52	
liquid temp	0	32	574,5	1962	494,4	3,05	10,40	2,62	188,6	1,20	6,66	
Tliq= 45/113	7,2	45	736,6	2516	634,0	3,70	12,63	3,18	199,1	1,23	8,65	
[°C / °F]	-35	-31	91,4	312	78,7	0,76	2,61	0,66	119,6	1,01	1,13	
cond. pressure	-25	-13	173,6	593	149,4	1,18	4,03	1,01	147,3	1,09	2,16	
pc= 55/131	-15	5	273,5	934	235,4	1,57	5,37	1,35	174,0	1,17	3,44	
return gas temp	-10	14	334,0	1141	287,4	1,79	6,11	1,54	186,8	1,20	4,22	
RGT= 32/90	-5	23	403,6	1378	347,3	2,03	6,93	1,75	199,0	1,23	5,14	
liquid temp	0	32	483,8	1652	416,4	2,30	7,85	1,98	210,5	1,27	6,21	
Tliq= 55/131	7,2	45	621,2	2122	534,6	2,75	9,40	2,37	225,8	1,32	8,09	

Model

Designation	KLF4.8CNT	208-230V/60Hz	Conf. 3	Sales code:	106H2507
-------------	------------------	----------------------	----------------	-------------	-----------------

Configuration

Motorconfiguration	CSIR
Power supply (nominal)	208-230V/60Hz 1~
Refrigerant	R290
Application	LBP+MBP
Voltage range	198-253V
Starting torque	HST
Approvals	UL CCC CB under prep.

Electrical accessories / wiring diagram

CSIR

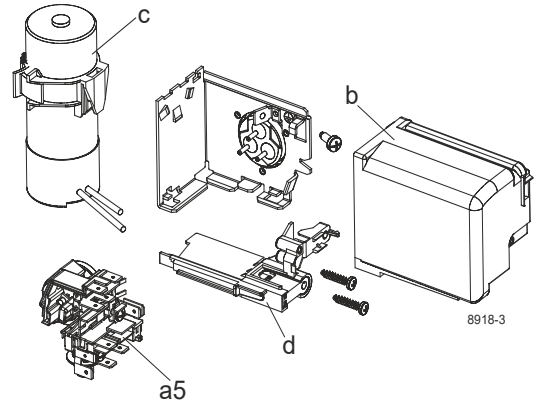

Ambient/ machine room temperatures minimum /maximum

Ambient temperature range:	10 - 43°C / 50 - 110°F
Machine room temperature range:	10 - 48°C / 50 - 119°F

Compressor cooling: fan 3m/s

Compressor with external protector. For max. operation envelope cooling on protector.

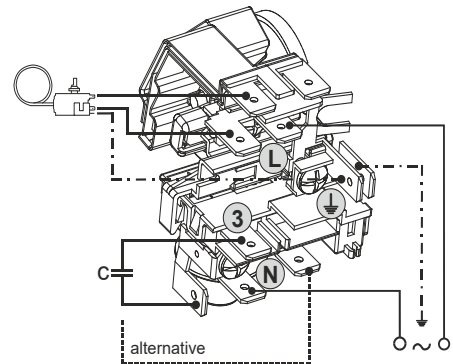
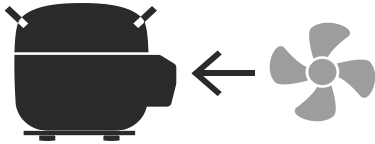

Operation pressure range

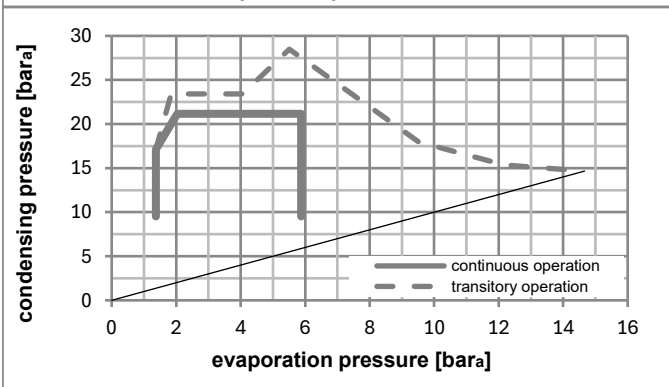
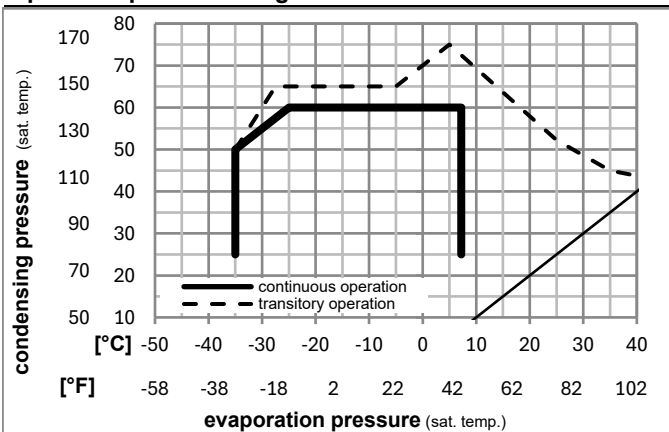

Components

a5	current relay TY (T0089/L6-S2)	117U7070
c	start capacitor (80µF, 6.3mm)	117U5003
b, d	cover + clamp + screws(5VA) in bag	103N1060

Alternative components

b, d	cover + clamp + screws(5VA-compl.)	103N0600
------	------------------------------------	----------

Model

Designation	KLF4.8CNT	208-230V/60Hz	Conf. 3	Sales code:	106H2507
-------------	------------------	----------------------	----------------	-------------	-----------------

Optimization + standard conditions

R290, 230V/60Hz, CSIR, fan 3m/s, UL, CCC, CB under prep.

		Evaporating pressure (saturation temperature)				Cooling capacity			COP			EER			Power consumption			
		Condensing pressure (saturation temperature)		Return gas temp.		Liquid temp.								Current consumption			Ref. mass flow	
		pe	pc	RGT	Tliq	[W]	[Btu/h]	[kcal/h]	[W/W]	[Btu/Wh]	[kcal/Wh]	P1	I	m	[W]	[A]	[kg/h]	
[°C]	-23	54	32	32	284,7	972	245,1	1,57	5,38	1,35	180,9	1,26	2,88	ASHRAE LBP				
[°F]	-10	130	90	90														
[°C]	-25	55	32	55	213,0	727	183,3	1,23	4,19	1,05	173,8	1,24	2,65	cecomaf LBP				
[°F]	-13	131	90	131														
[°C]	-35	40	20	40	160,5	548	138,2	1,19	4,07	1,03	134,7	1,14	1,83	EN12900 LBP				
[°F]	-31	104	68	104														
[°C]	-7	54	35	46	520,0	1776	447,5	2,09	7,13	1,80	249,1	1,47	5,93	ASHRAE MBP				
[°F]	20	130	95	115														
[°C]	-10	55	32	55	411,0	1404	353,7	1,73	5,92	1,49	237,1	1,43	5,20	cecomaf MBP				
[°F]	14	131	90	131														
[°C]	-10	45	20	45	462,7	1580	398,2	2,09	7,12	1,79	221,9	1,38	5,68	EN12900 MBP				
[°F]	14	113	68	113														

Performance tables

R290, 230V/60Hz, CSIR, fan 3m/s, UL, CCC, CB under prep.

	pe		Cooling capacity			COP			EER			P1			I			m		
	[°C]	[°F]	[W]	[Btu/h]	[kcal/h]	[W/W]	[Btu/Wh]	[kcal/Wh]	[W]	[A]	[kg/h]	[W]	[A]	[kg/h]	[W]	[A]	[kg/h]	[W]	[A]	[kg/h]
[°C / °F]	-35	-31	152,8	522	131,5	1,13	3,85	0,97	135,7	1,15	1,71									
cond. pressure	-25	-13	253,2	865	217,9	1,48	5,05	1,27	171,1	1,23	2,86									
pc= 45/113	-15	5	394,3	1347	339,3	1,91	6,53	1,65	206,1	1,33	4,49									
return gas temp.	-10	14	481,7	1645	414,6	2,17	7,41	1,87	221,9	1,38	5,51									
RGT= 32/90	-5	23	581,2	1985	500,2	2,46	8,42	2,12	235,9	1,42	6,69									
liquid temp	0	32	693,5	2369	596,9	2,80	9,57	2,41	247,4	1,46	8,04									
Tliq= 45/113	7,2	45	879,0	3002	756,5	3,40	11,61	2,92	258,6	1,50	10,33									
[°C / °F]	-35	-31	130,2	445	112,0	0,98	3,36	0,85	132,4	1,14	1,61									
cond. pressure	-25	-13	213,0	727	183,3	1,23	4,19	1,05	173,8	1,24	2,65									
pc= 55/131	-15	5	334,3	1142	287,7	1,54	5,27	1,33	216,6	1,36	4,20									
return gas temp	-10	14	411,0	1404	353,7	1,73	5,92	1,49	237,1	1,43	5,20									
RGT= 32/90	-5	23	499,3	1705	429,7	1,95	6,66	1,68	256,2	1,49	6,36									
liquid temp	0	32	599,8	2048	516,2	2,19	7,49	1,89	273,3	1,55	7,70									
Tliq= 55/131	7,2	45	767,2	2620	660,2	2,61	8,93	2,25	293,4	1,62	9,99									

Model

Designation	KLF4.8CNT	208-230V/60Hz	Conf. 4	Sales code:	106H2507
-------------	------------------	----------------------	----------------	-------------	-----------------

Configuration

Motorconfiguration	RSCR
Power supply (nominal)	208-230V/60Hz 1~
Refrigerant	R290
Application	LBP+MBP
Voltage range	198-253V
Starting torque	LST
Approvals	UL CCC CB under prep.

Electrical accessories / wiring diagram

RSCR

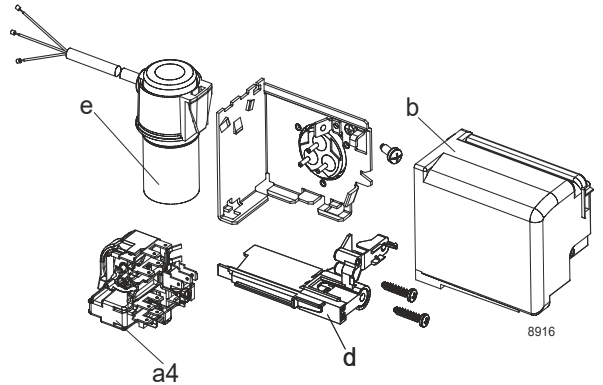

Ambient/ machine room temperatures minimum /maximum

Ambient temperature range:	10 - 43°C / 50 - 110°F
Machine room temperature range:	10 - 48°C / 50 - 119°F

Compressor cooling: fan 3m/s

Compressor with external protector. For max. operation envelope cooling on protector.

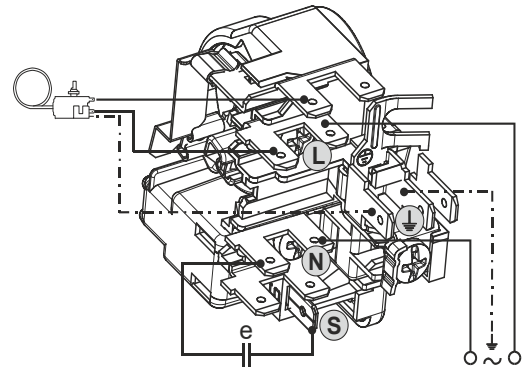
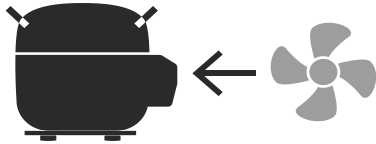

Operation pressure range

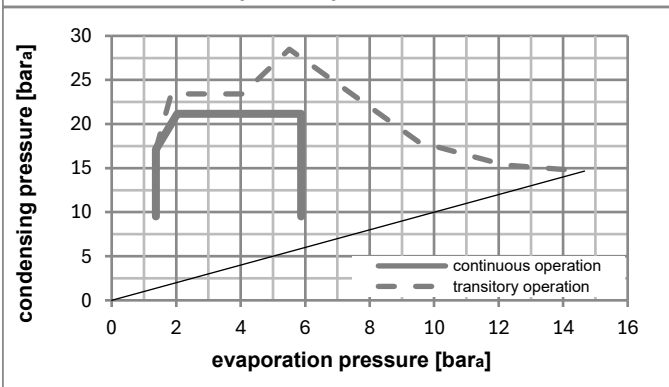
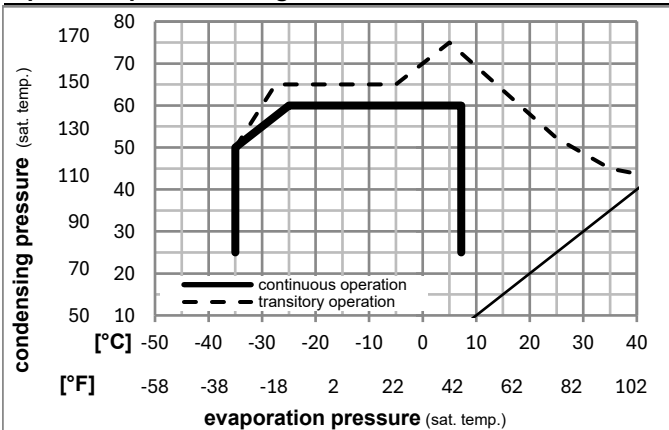

Components

a4	DAS2 (PTC,6.3mm, T0089/L6 - S2)	103N0251
e	run capacitor (5µF, 6,3mm)	117-7155
b, d	cover + clamp + screws(5VA) in bag	103N1060

Alternative components

b, d	cover + clamp + screws(5VA-compl.)	103N0600
------	------------------------------------	----------

Model

Designation	KLF4.8CNT	208-230V/60Hz	Conf. 4	Sales code:	106H2507
-------------	------------------	----------------------	----------------	-------------	-----------------

Optimization + standard conditions

R290, 230V/60Hz, RSCR, fan 3m/s, UL, CCC, CB under prep.

	Evaporating pressure (saturation temperature)				Cooling capacity			COP	EER	P1	Power consumption		ASHRAE LBP	
	pe	pc	RGT	Tliq	[W]	[Btu/h]	[kcal/h]				I	m		
	[°C]	[°F]	[°C]	[°C]				[W/W]	[Btu/Wh]	[kcal/Wh]	[W]	[A]	[kg/h]	
	-23	54	32	32	279,2	954	240,3	1,64	5,61	1,41	169,9	0,91	2,83	ASHRAE LBP
	-10	130	90	90										
	-25	55	32	55	209,7	716	180,4	1,28	4,36	1,10	164,1	0,88	2,61	cecomaf LBP
	-13	131	90	131										
	-35	40	20	40	167,5	572	144,1	1,24	4,23	1,07	135,3	0,78	1,91	EN12900 LBP
	-31	104	68	104										
	-7	54	35	46	510,5	1743	439,3	2,21	7,54	1,90	231,1	1,16	5,82	ASHRAE MBP
	20	130	95	115										
	-10	55	32	55	402,5	1375	346,4	1,83	6,25	1,57	220,0	1,12	5,09	cecomaf MBP
	14	131	90	131										
	-10	45	20	45	464,3	1586	399,6	2,18	7,45	1,88	213,0	1,09	5,70	EN12900 MBP
	14	113	68	113										

Performance tables

R290, 230V/60Hz, RSCR, fan 3m/s, UL, CCC, CB under prep.

	pe		Cooling capacity			COP	EER	P1	I	m	
	[°C]	[°F]	[W]	[Btu/h]	[kcal/h]						
[°C / °F]	-35	-31	156,8	536	135,0	1,17	4,00	1,01	133,7	0,77	1,76
cond. pressure	-25	-13	257,1	878	221,3	1,54	5,25	1,32	167,4	0,90	2,90
pc= 45/113	-15	5	396,4	1354	341,1	1,99	6,81	1,72	198,7	1,03	4,51
return gas temp.	-10	14	483,4	1651	416,0	2,27	7,75	1,95	213,0	1,09	5,53
RGT= 32/90	-5	23	583,3	1992	502,0	2,58	8,81	2,22	226,0	1,14	6,72
liquid temp	0	32	697,2	2381	600,0	2,93	10,02	2,53	237,6	1,19	8,09
Tliq= 45/113	7,2	45	888,1	3033	764,3	3,53	12,07	3,04	251,4	1,25	10,43
[°C / °F]	-35	-31	131,3	448	113,0	1,03	3,51	0,88	127,8	0,75	1,62
cond. pressure	-25	-13	209,7	716	180,4	1,28	4,36	1,10	164,1	0,88	2,61
pc= 55/131	-15	5	326,8	1116	281,2	1,62	5,54	1,40	201,5	1,04	4,11
return gas temp	-10	14	402,5	1375	346,4	1,83	6,25	1,57	220,0	1,12	5,09
RGT= 32/90	-5	23	491,1	1677	422,6	2,06	7,04	1,77	238,2	1,19	6,26
liquid temp	0	32	593,6	2027	510,9	2,32	7,93	2,00	255,7	1,27	7,62
Tliq= 55/131	7,2	45	768,0	2623	660,9	2,75	9,38	2,36	279,6	1,37	10,00