

Model

Designation	KLF4.8CNT	200-240V/50Hz 1~ 208-230V/60Hz 1~	Sales code:	106H2512
-------------	------------------	-----------------------------------	-------------	-----------------

Compressor design

Oil type	Polyolester	Refrigerant(s)	R290
Oil viscosity	19,2cST	Displacement	4,8cm ³ / 0,29cu.in
Oil quantity	162cm ³ / 5,5fl.oz	Compressors on pallet	100
Refr. charge - tech. limit	200g / 7,1oz		
Free gas volume comp.	1615cm ³ / 54,6fl.oz		
Weight	9,2kg / 20,3lbs		
Motor protection	external		
Winding resistance main	10,7Ω (at 25°C)		
Winding resistance aux	17Ω (at 25°C)		
Max. winding temp.	125°C / 257°F		
Max. discharge temp.	130°C / 266°F		



General - Configurations with KLF4.8CNT

	Conf. 1	Conf. 2
Motorconfiguration	CSIR	CSIR
Power supply (nominal)	200-240V/50Hz	208-230V/60Hz
Number of phases	1	1
Voltage range	187-254V	198-253V
Approvals	UL, CCC, CB	UL, CCC, CB, KC
Starting torque	HST	HST
Note	Electrical equipment is included and pre-assembled to compressor.	

Applications with KLF4.8CNT

	Conf. 1	Conf. 2
Refrigerant	R290	R290
Application	LBP+MBP	LBP+MBP
System cooling	fan 3m/s	fan 3m/s
Hot gas defrost	OK	OK
Long interval pull down	OK	-/-

Electrical data - Configurations with KLF4.8CNT

	Conf. 1	Conf. 2
Starting device type	relay	relay
Run capacitor	-/-	-/-
Start capacitor	80μF	80μF
LRA (locked rotor amps / 4s)	10,7A	10,7A
RLA (rated load amps / 1s)	1,7A	1,7A
Cut in current	10,7A	10,7A

Model

Designation

KLF4.8CNT

200-240V/50Hz 1~ 208-230V/60Hz 1~

Sales code:

106H2512

Compressor dimensions

Housing	A Height	182mm / 7,17in
	B Height	175mm / 6,89in
	C Length shell	198mm / 7,8in
	D Length w. cover	238mm / 9,37in
	E Width	160mm / 6,3in

Connectors		Suction	Discharge	Process
		X	Y	Z
Diameter	[mm]	øi 8,11-8,29	øi 6,11-6,29	øi 6,11-6,29
	(i:inside, o:outside) [in]	øi 0,32-0,33	øi 0,24-0,25	øi 0,24-0,25
Material		copper	copper	copper
Horizontal angle	±2°	35°	13°	0°
Vertical angle	±2°	30°	40°	145°
Position l/h/w	[mm]	120/72/57	112/106/81	-97/94/72
	[in]	4,7/2,8/2,2	4,4/4,2/3,2	-3,8/3,7/2,8
Straight tube l.	[mm]	14	14	14
	[in]	0,5	0,5	0,5

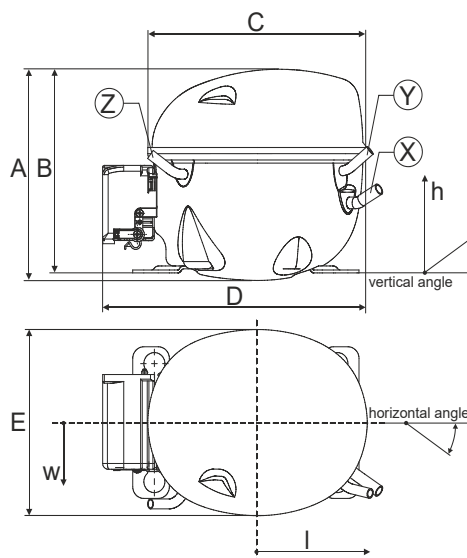

Compressor fixation

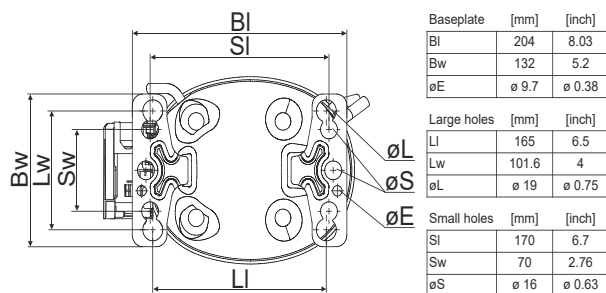

Bolt joint



Snap-on

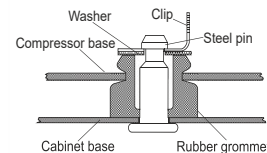

Mounting accessories

	one comp.	multi pack
Bolt joint M6 ø16mm	118-1917	118-1918
Bolt joint ø1/4" ø16mm	118-1946	
Bolt joint ø1/4" ø19mm	118-1949	
Snap-on ø7,3 ø16mm	118-1947	118-1919

Application notes

LRA value on compressor label and datasheet may differ due to different test conditions for UL approval.

Provision for PE Grounding is located at the PE Stamp on the compressor

Model

Designation	KLF4.8CNT	200-240V/50Hz	Conf. 1	Sales code:	106H2512
-------------	------------------	----------------------	---------	-------------	-----------------

Configuration

Motorconfiguration	CSIR
Power supply (nominal)	200-240V/50Hz 1~
Refrigerant	R290
Application	LBP+MBP
Voltage range	187-254V
Starting torque	HST
Approvals	UL
	CCC
	CB

Electrical accessories / wiring diagram

CSIR

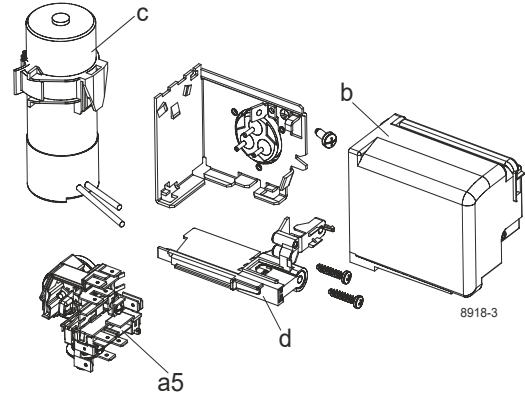

Ambient/ machine room temperatures minimum /maximum

Ambient temperature range: 10 - 43°C / 50 - 110°F

Machine room temperature range: 10 - 48°C / 50 - 119°F

Compressor cooling: fan 3m/s

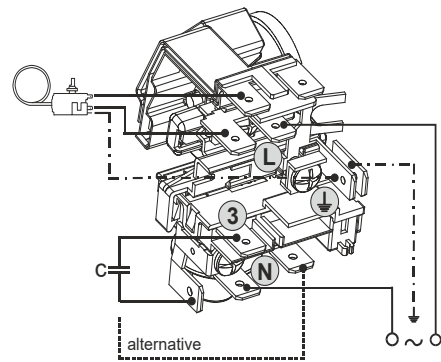

Operation pressure range

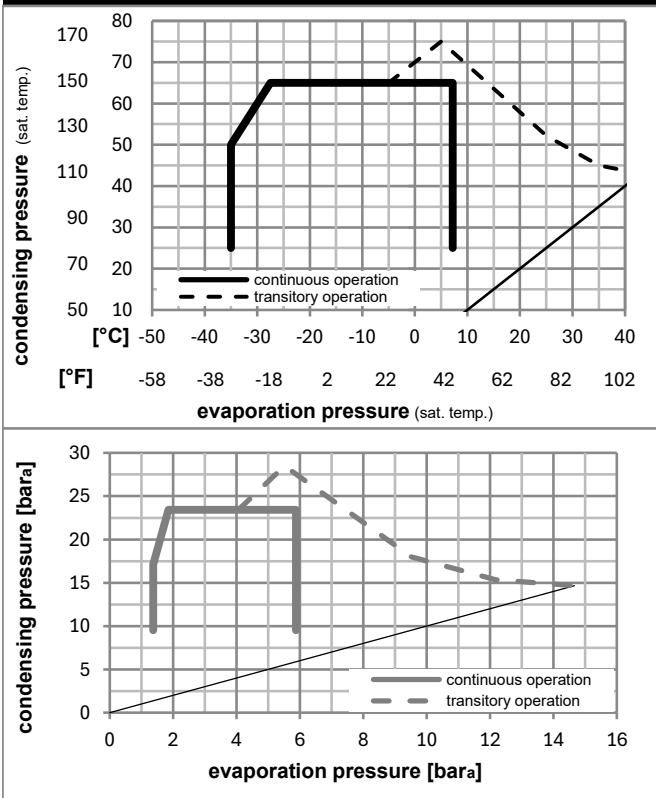

Components (already pre-assembled)

a5	current relay (T0089/L6-S2)	117U7070
c	start capacitor (80µF, 6.3mm)	117U5003
b	cover terminal board	10636401
.	screw uni en iso 4757	10641201

Alternative comp. (already pre-assembled)

.	cable clamp (screws not included)	16058100
.	screw - uni6954	10636000
.	screw - uni6954	10636200

Model

Designation **KLF4.8CNT** **200-240V/50Hz** Conf. 1 Sales code: **106H2512**

Optimization + standard conditions

R290, 220V/50Hz, CSIR, fan 3m/s, UL, CCC, CB

	Evaporating pressure (saturation temperature)				Cooling capacity			COP	EER	P1	Power consumption		ASHRAE LBP					
	pe	pc	RGT	Tliq	[W]	[Btu/h]	[kcal/h]				I	m						
	[°C]	[°F]	[°C]	[°F]	[W]	[Btu/h]	[kcal/h]	[W/W]	[Btu/Wh]	[kcal/Wh]	[W]	[A]	[kg/h]					
	-23	-10	54	130	32	90	32	90	228,7	781	196,8	1,48	5,05	1,27	154,6	1,38	2,32	ASHRAE LBP
	-25	-13	55	131	32	90	55	131	170,2	581	146,5	1,13	3,87	0,97	150,3	1,37	2,12	cecomaf LBP
	-35	-31	40	104	20	68	40	104	131,9	450	113,5	1,08	3,69	0,93	122,1	1,33	1,51	EN12900 LBP
	-7	20	54	130	35	95	46	115	420,2	1435	361,7	2,07	7,07	1,78	202,9	1,49	4,79	ASHRAE MBP
	-10	14	55	131	32	90	55	131	332,3	1135	286,0	1,71	5,83	1,47	194,6	1,47	4,20	cecomaf MBP
	-10	14	45	113	20	68	45	113	384,6	1314	331,0	2,14	7,29	1,84	180,1	1,43	4,72	EN12900 MBP

Performance tables

R290, 220V/50Hz, CSIR, fan 3m/s, UL, CCC, CB

	pe		Cooling capacity			COP	EER		P1	I	m
	[°C]	[°F]	[W]	[Btu/h]	[kcal/h]		[Btu/Wh]	[kcal/Wh]			
[°C / °F]	-35	-31	121,2	414	104,3	0,99	3,37	0,85	122,7	1,33	1,36
cond. pressure	-25	-13	211,4	722	181,9	1,45	4,95	1,25	145,9	1,36	2,38
pc= 45/113	-15	5	328,2	1121	282,5	1,94	6,63	1,67	169,0	1,41	3,73
return gas temp.	-10	14	400,4	1367	344,6	2,22	7,59	1,91	180,1	1,43	4,58
RGT= 32/90	-5	23	483,7	1652	416,3	2,54	8,67	2,19	190,5	1,45	5,57
liquid temp	0	32	579,7	1980	498,9	2,90	9,89	2,49	200,2	1,48	6,72
Tliq= 45/113	7,2	45	743,2	2538	639,6	3,50	11,96	3,01	212,3	1,51	8,73
[°C / °F]	-35	-31	90,2	308	77,6	0,74	2,53	0,64	121,6	1,32	1,12
cond. pressure	-25	-13	170,2	581	146,5	1,13	3,87	0,97	150,3	1,37	2,12
pc= 55/131	-15	5	270,6	924	232,9	1,50	5,14	1,29	179,9	1,43	3,40
return gas temp	-10	14	332,3	1135	286,0	1,71	5,83	1,47	194,6	1,47	4,20
RGT= 32/90	-5	23	403,5	1378	347,3	1,93	6,59	1,66	209,0	1,50	5,14
liquid temp	0	32	485,8	1659	418,1	2,18	7,45	1,88	222,8	1,54	6,24
Tliq= 55/131	7,2	45	626,9	2141	539,5	2,60	8,87	2,24	241,3	1,60	8,17

Model

Designation	KLF4.8CNT	208-230V/60Hz	Conf. 2	Sales code:	106H2512
-------------	------------------	----------------------	----------------	-------------	-----------------

Configuration

Motorconfiguration	CSIR
Power supply (nominal)	208-230V/60Hz 1~
Refrigerant	R290
Application	LBP+MBP
Voltage range	198-253V
Starting torque	HST
Approvals	UL
	CCC
	CB
	KC

Electrical accessories / wiring diagram

CSIR

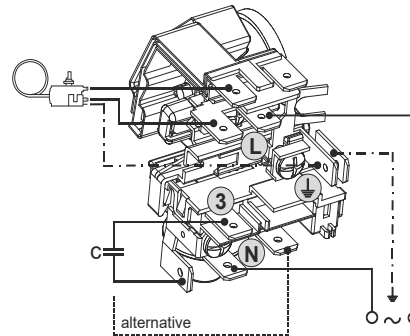
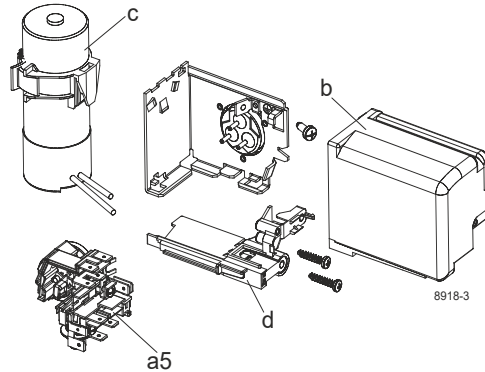

Ambient/ machine room temperatures minimum /maximum

Ambient temperature range: 10 - 43°C / 50 - 110°F

Machine room temperature range: 10 - 48°C / 50 - 119°F

Compressor cooling: fan 3m/s

Operation pressure range

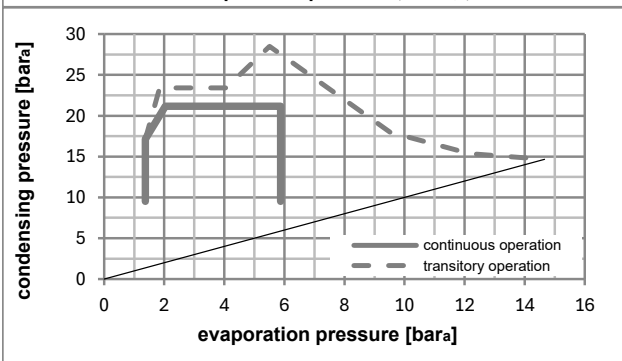
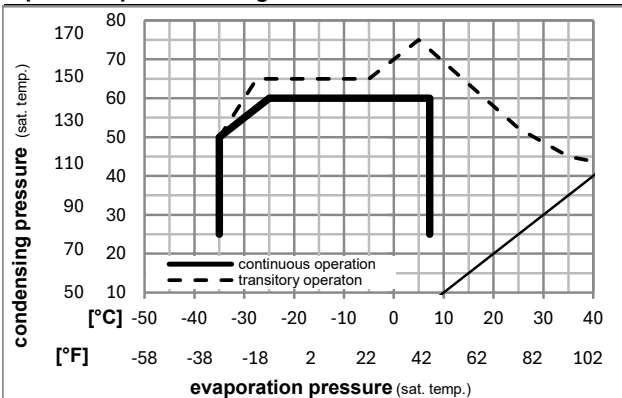

Components (already pre-assembled)

a5	current relay (T0089/L6-S2)	117U7070
c	start capacitor (80µF, 6.3mm)	117U5003
b	cover terminal board	10636401
.	screw uni en iso 4757	10641201

Alternative comp. (already pre-assembled)

.	cable clamp (screws not included)	16058100
.	screw - uni6954	10636000
.	screw - uni6954	10636200

Model

Designation	KLF4.8CNT	208-230V/60Hz	Conf. 2	Sales code:	106H2512
-------------	------------------	----------------------	----------------	-------------	-----------------

Optimization + standard conditions

R290, 230V/60Hz, CSIR, fan 3m/s, UL, CCC, CB, KC

		Evaporating pressure (saturation temperature)				Cooling capacity			COP			EER			Power consumption			
		Condensing pressure (saturation temperature)				Return gas temp.			Liqud temp.			P1			Current consumption			Ref. mass flow
		pe	pc	RGT	Tliq	[W]	[Btu/h]	[kcal/h]	[W/W]	[Btu/Wh]	[kcal/Wh]	[W]	I	m	[A]	[kg/h]		
[°C]	-23	54	32	32	284,7	972	245,1	1,57	5,38	1,35	180,9	1,26	2,88	ASHRAE LBP				
[°F]	-10	130	90	90														
[°C]	-25	55	32	55	213,0	727	183,3	1,23	4,19	1,05	173,8	1,24	2,65	cecomaf LBP				
[°F]	-13	131	90	131														
[°C]	-35	40	20	40	160,5	548	138,2	1,19	4,07	1,03	134,7	1,14	1,83	EN12900 LBP				
[°F]	-31	104	68	104														
[°C]	-7	54	35	46	520,0	1776	447,5	2,09	7,13	1,80	249,1	1,47	5,93	ASHRAE MBP				
[°F]	20	130	95	115														
[°C]	-10	55	32	55	411,0	1404	353,7	1,73	5,92	1,49	237,1	1,43	5,20	cecomaf MBP				
[°F]	14	131	90	131														
[°C]	-10	45	20	45	462,7	1580	398,2	2,09	7,12	1,79	221,9	1,38	5,68	EN12900 MBP				
[°F]	14	113	68	113														

Performance tables

R290, 230V/60Hz, CSIR, fan 3m/s, UL, CCC, CB, KC

	pe		Cooling capacity			COP			EER			P1			I			m			
	[°C]	[°F]	[W]	[Btu/h]	[kcal/h]	[W/W]	[Btu/Wh]	[kcal/Wh]	[W]	[A]	[kg/h]	[W]	[A]	[kg/h]	[W]	[A]	[kg/h]	[W]	[A]	[kg/h]	
[°C / °F]	-35	-31	152,8	522	131,5	1,13	3,85	0,97	135,7	1,15	1,71										
cond. pressure	-25	-13	253,2	865	217,9	1,48	5,05	1,27	171,1	1,23	2,86										
pc= 45/113	-15	5	394,3	1347	339,3	1,91	6,53	1,65	206,1	1,33	4,49										
return gas temp.	-10	14	481,7	1645	414,6	2,17	7,41	1,87	221,9	1,38	5,51										
RGT= 32/90	-5	23	581,2	1985	500,2	2,46	8,42	2,12	235,9	1,42	6,69										
liquid temp	0	32	693,5	2369	596,9	2,80	9,57	2,41	247,4	1,46	8,04										
Tliq= 45/113	7,2	45	879,0	3002	756,5	3,40	11,61	2,92	258,6	1,50	10,33										
[°C / °F]	-35	-31	130,2	445	112,0	0,98	3,36	0,85	132,4	1,14	1,61										
cond. pressure	-25	-13	213,0	727	183,3	1,23	4,19	1,05	173,8	1,24	2,65										
pc= 55/131	-15	5	334,3	1142	287,7	1,54	5,27	1,33	216,6	1,36	4,20										
return gas temp	-10	14	411,0	1404	353,7	1,73	5,92	1,49	237,1	1,43	5,20										
RGT= 32/90	-5	23	499,3	1705	429,7	1,95	6,66	1,68	256,2	1,49	6,36										
liquid temp	0	32	599,8	2048	516,2	2,19	7,49	1,89	273,3	1,55	7,70										
Tliq= 55/131	7,2	45	767,2	2620	660,2	2,61	8,93	2,25	293,4	1,62	9,99										