

Model

Designation	KLF5.6CND	220-240V/50Hz 1~	Sales code:	106H2600
-------------	------------------	------------------	-------------	-----------------

Compressor design

Oil type	Polyolester	Refrigerant(s)	R290
Oil viscosity	10,4cSt	Displacement	5,6cm ³ / 0,34cu.in
Oil quantity	174cm ³ / 5,9fl.oz	Compressors on pallet	100
Refr. charge - tech. limit	200g / 7,1oz		
Free gas volume comp.	1605cm ³ / 54,3fl.oz		
Weight	9,4kg / 20,7lbs		
Motor protection	external		
Winding resistance main	10,7Ω (at 25°C)		
Winding resistance aux	17Ω (at 25°C)		
Max. winding temp.	125°C / 257°F		
Max. discharge temp.	130°C / 266°F		



General - Configurations with KLF5.6CND

	Conf. 1	Conf. 2
Motorconfiguration	CSIR	RSCR
Power supply (nominal)	220-240V/50Hz	220-240V/50Hz
Number of phases	1	1
Voltage range	198-254V	198-254V
Approvals	VDE, CCC	VDE, CCC
Starting torque	HST	LST
Note	- / -	

Applications with KLF5.6CND

	Conf. 1	Conf. 2
Refrigerant	R290	R290
Application	LBP+MBP	LBP+MBP
System cooling	fan 3m/s	fan 3m/s
Hot gas defrost	OK	OK
Long interval pull down	OK	OK

Electrical data - Configurations with KLF5.6CND

	Conf. 1	Conf. 2
Starting device type	relay	PTC
Run capacitor	-/-	5μF
Start capacitor	80μF	-/-
LRA (locked rotor amps / 4s/ U(N))	11,4A	11,4A
RLA (rated load amps / 1s/ U(N))	1,6A	1,6A
Cut in current (U(N))	10,7A	14,7A

Model

Designation	KLF5.6CND	220-240V/50Hz 1~	Sales code:	106H2600
-------------	------------------	------------------	-------------	-----------------

Compressor dimensions

Housing	A Height	182mm / 7,17in
	B Height	175mm / 6,89in
	C Length shell	198mm / 7,8in
	D Length w. cover	238mm / 9,37in
	E Width	160mm / 6,3in

Connectors		Suction	Discharge	Process
		X	Y	Z
Diameter	[mm]	øi 8,11-8,29	øi 6,11-6,29	øi 6,11-6,29
(i:inside, o:outside)	[in]	øi 0,32-0,33	øi 0,24-0,25	øi 0,24-0,25
Material		copper	copper	copper
Horizontal angle	±2°	35°	13°	0°
Vertical angle	±2°	30°	40°	145°
Position l/h/w	[mm]	119/73/59	117/107/66	-88/101/71
	[in]	4,7/2,9/2,3	4,6/4,2/2,6	-3,5/4/2,8
Straight tube l.	[mm]	14	14	14
	[in]	0,5	0,5	0,5

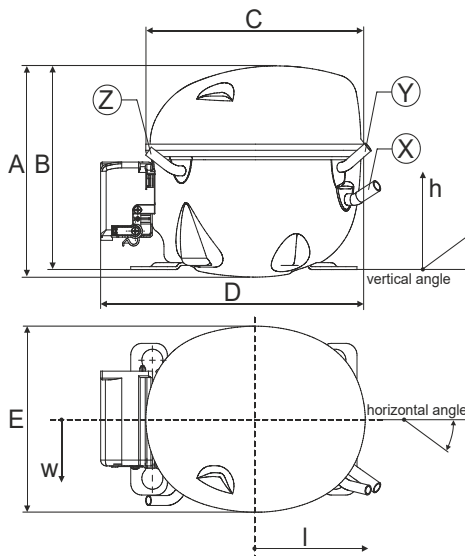

Compressor fixation



Bolt joint



Snap-on

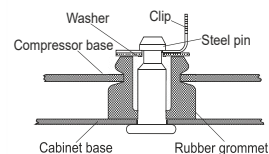

Mounting accessories	one comp.	multi pack
Bolt joint M6 ø16mm	118-1917	118-1918
Bolt joint ø1/4" ø16mm	118-1946	
Bolt joint ø1/4" ø19mm	118-1949	
Snap-on ø7,3 ø16mm	118-1947	118-1919

Application notes

Provision for PE Grounding is located at the PE Stamp on the compressor

Model

Designation	KLF5.6CND	220-240V/50Hz	Conf. 1	Sales code:	106H2600
-------------	------------------	----------------------	----------------	-------------	-----------------

Configuration

Motorconfiguration	CSIR
Power supply (nominal)	220-240V/50Hz 1~
Refrigerant	R290
Application	LBP+MBP
Voltage range	198-254V
Starting torque	HST
Approvals	VDE CCC

Electrical accessories / wiring diagram

CSIR

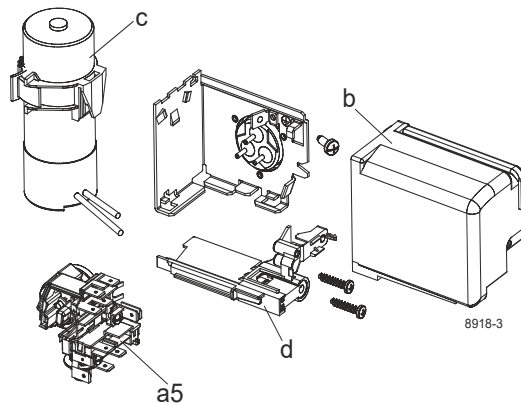

Ambient/ machine room temperatures minimum /maximum

Ambient temperature range: 10 - 43°C / 50 - 110°F

Machine room temperature range: 10 - 48°C / 50 - 119°F

Compressor cooling: fan 3m/s

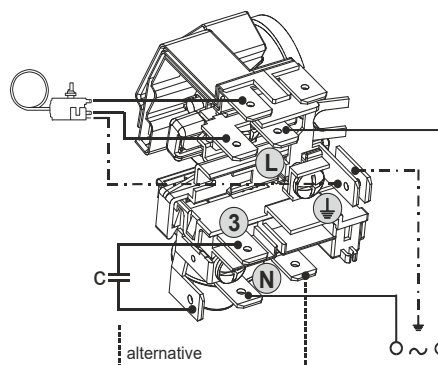

Operation pressure range

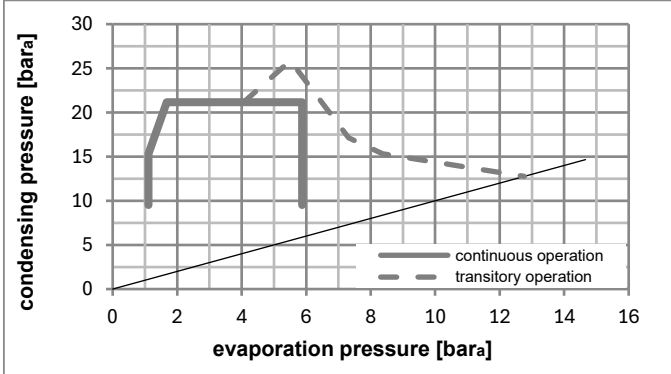
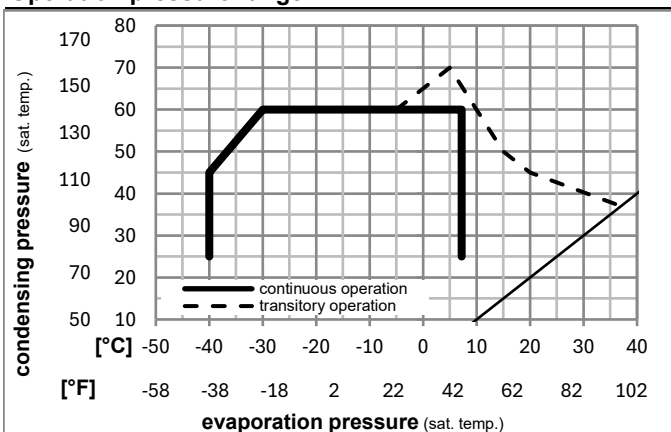

Components

a5	current relay (T0089/L6-S2)	117U7070
c	start capacitor (80µF, 6.3mm)	117U5001
b, d	cover + clamp + screws(5VA) in bag	103N1060

Alternative components

b, d	100x cover + clamp + screws(5VA)	103N2060
b, d	cover + clamp + screws(5VA-compl.)	103N0600

Model

Designation **KLF5.6CND** **220-240V/50Hz** Conf. 1 Sales code: **106H2600**

Optimization + standard conditions

R290, 220V/50Hz, CSIR, fan 3m/s, VDE, CCC

	pe	pc	RGT	Tliq	Cooling capacity	COP	EER	P1	I	Ref. mass flow	
	[°C]	[°C]	[°C]	[°C]	[W]	[W/W]	[Btu/Wh]	[W]	[A]	[kg/h]	
ASHRAE LBP	-23	54	32	32	273,6	1,55	5,28	177,1	1,22	2,77	
	[°F]	[°F]	[°F]	[°F]	[Btu/h]	[kcal/h]	[kcal/Wh]	[W]	[A]	[kg/h]	
	-10	130	90	90	934	235,5	1,33	177,1	1,22	2,77	
cecomaf LBP	-25	55	32	55	203,7	1,19	4,07	170,9	1,20	2,54	
	[°F]	[°F]	[°F]	[°F]	[W]	[W/W]	[Btu/Wh]	[W]	[A]	[kg/h]	
	-13	131	90	131	696	175,3	1,03	170,9	1,20	2,54	
EN12900 LBP	-35	40	20	40	149,1	1,21	4,12	123,4	1,07	1,70	
	[°F]	[°F]	[°F]	[°F]	[W]	[W/W]	[Btu/Wh]	[W]	[A]	[kg/h]	
	-31	104	68	104	509	128,3	1,04	123,4	1,07	1,70	
ASHRAE MBP	-7	54	35	46	494,7	2,07	7,08	238,8	1,43	5,64	
	[°F]	[°F]	[°F]	[°F]	[W]	[W/W]	[Btu/Wh]	[W]	[A]	[kg/h]	
	20	130	95	115	1690	425,8	1,78	238,8	1,43	5,64	
cecomaf MBP	-10	55	32	55	392,2	1,72	5,87	228,2	1,39	4,96	
	[°F]	[°F]	[°F]	[°F]	[W]	[W/W]	[Btu/Wh]	[W]	[A]	[kg/h]	
	14	131	90	131	1339	337,5	1,48	228,2	1,39	4,96	
EN12900 MBP	-10	45	20	45	435,1	2,09	7,14	208,0	1,32	5,34	
	[°F]	[°F]	[°F]	[°F]	[W]	[W/W]	[Btu/Wh]	[W]	[A]	[kg/h]	
	14	113	68	113	1486	374,4	1,80	208,0	1,32	5,34	

Performance tables

R290, 220V/50Hz, CSIR, fan 3m/s, VDE, CCC

	pe	Cooling capacity	COP	EER	P1	I	m
	[°C]	[W]	[W/W]	[Btu/Wh]	[W]	[A]	[kg/h]
[°C / °F]	-40	112,6	0,97	3,31	116,1	1,06	1,26
cond. pressure	-35	148,4	1,14	3,88	130,6	1,09	1,66
pc= 45/113	-25	241,0	1,49	5,08	162,1	1,17	2,72
return gas temp.	-15	370,8	1,92	6,54	193,5	1,27	4,22
RGT= 32/90	-5	548,3	2,48	8,47	221,0	1,36	6,31
liquid temp	0	658,2	2,84	9,69	232,0	1,40	7,63
Tliq= 45/113	7,2	844,8	3,47	11,85	243,5	1,45	9,93
[°C / °F]	-40	76,0	0,65	2,24	116,1	1,06	0,94
cond. pressure	-35	114,0	0,86	2,92	133,3	1,10	1,41
pc= 55/131	-25	203,7	1,19	4,07	170,9	1,20	2,54
return gas temp	-15	320,4	1,53	5,22	209,6	1,33	4,03
RGT= 32/90	-5	474,8	1,93	6,60	245,7	1,46	6,05
liquid temp	0	569,4	2,18	7,43	261,5	1,52	7,31
Tliq= 55/131	7,2	729,5	2,60	8,88	280,5	1,59	9,50

Model

Designation	KLF5.6CND	220-240V/50Hz	Conf. 2	Sales code:	106H2600
-------------	------------------	----------------------	----------------	-------------	-----------------

Configuration

Motor configuration	RSCR
Power supply (nominal)	220-240V/50Hz 1~
Refrigerant	R290
Application	LBP+MBP
Voltage range	198-254V
Starting torque	LST
Approvals	VDE CCC

Electrical accessories / wiring diagram

RSCR

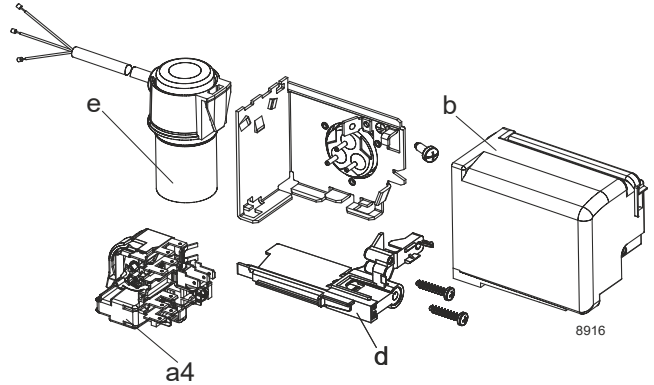

Ambient/ machine room temperatures minimum /maximum

Ambient temperature range:	10 - 43°C / 50 - 110°F
Machine room temperature range:	10 - 48°C / 50 - 119°F
Compressor cooling:	fan 3m/s

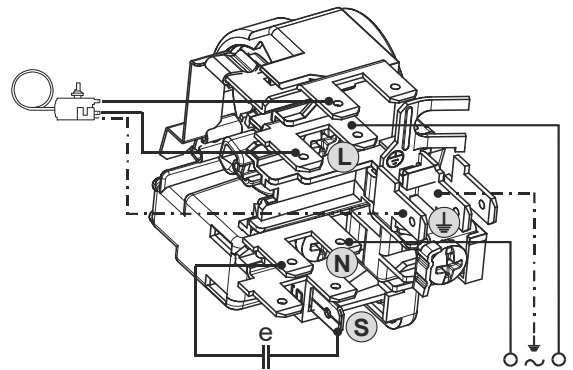

Operation pressure range

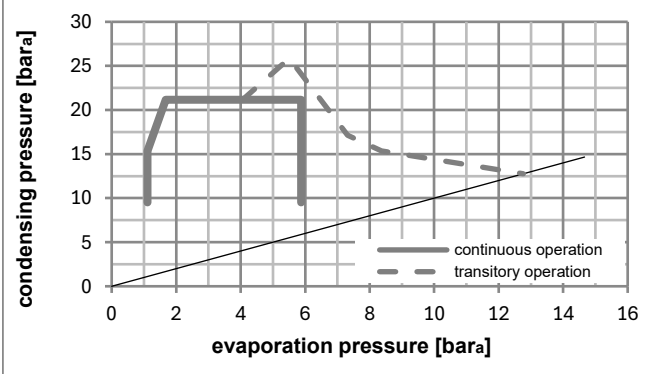
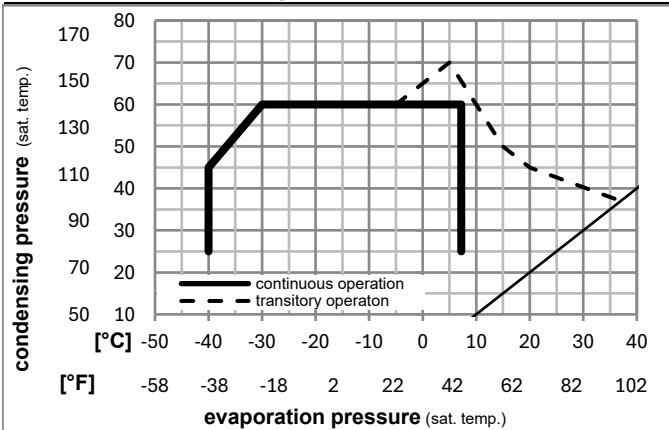

Components

a4	DAS2 (PTC,6.3mm, T0089/L6 - S2)	103N0251
e	run capacitor (5μF, 6.3mm)	117-7191
b, d	cover + clamp + screws(5VA) in bag	103N1060

Alternative components

a4	ZAS2 (PTC,4.8mm, T0089/L6 - S2)	103N0253
e	run capacitor (5μF, 4.8mm)	117-7190

b, d	100x cover + clamp + screws(5VA)	103N2060
b, d	cover + clamp + screws(5VA-compl.)	103N0600

Model

Designation **KLF5.6CND** **220-240V/50Hz** Conf. 2 Sales code: **106H2600**

Optimization + standard conditions

R290, 220V/50Hz, RSCR, fan 3m/s, VDE, CCC

	Evaporating pressure (saturation temperature)				Cooling capacity	COP	EER	Power consumption			ASHRAE LBP			
	pe	pc	RGT	Tliq				P1	I	m				
	[°C]	[°F]	[°C]	[°F]	[W]	[Btu/h]	[kcal/h]	[W/W]	[Btu/Wh]	[kcal/Wh]	[W]	[A]	[kg/h]	
	-23	54	32	32	276,8	945	238,2	1,62	5,52	1,39	171,3	0,92	2,80	ASHRAE LBP
	-10	130	90	90										
	-25	55	32	55	206,0	704	177,3	1,25	4,26	1,07	165,3	0,90	2,57	cecomaf LBP
	-13	131	90	131										
	-35	40	20	40	150,7	515	129,7	1,26	4,29	1,08	120,0	0,73	1,72	EN12900 LBP
	-31	104	68	104										
	-7	54	35	46	500,8	1710	431,0	2,17	7,40	1,86	231,2	1,17	5,71	ASHRAE MBP
	20	130	95	115										
	-10	55	32	55	397,0	1356	341,7	1,80	6,14	1,55	221,0	1,13	5,02	cecomaf MBP
	14	131	90	131										
	-10	45	20	45	440,3	1504	378,9	2,18	7,46	1,88	201,5	1,05	5,41	EN12900 MBP
	14	113	68	113										

Performance tables

R290, 220V/50Hz, RSCR, fan 3m/s, VDE, CCC

	pe		Cooling capacity			COP	EER	P1	I	m	
	[°C]	[°F]	[W]	[Btu/h]	[kcal/h]	[W/W]	[Btu/Wh]	[kcal/Wh]	[W]	[A]	[kg/h]
[°C / °F]	-40	-40	113,9	389	98,0	1,01	3,44	0,87	113,1	0,71	1,27
cond. pressure	-35	-31	150,0	512	129,1	1,18	4,04	1,02	126,8	0,75	1,68
pc= 45/113	-25	-13	243,8	833	209,8	1,55	5,31	1,34	156,9	0,86	2,75
return gas temp.	-15	5	375,2	1281	322,9	2,00	6,84	1,72	187,4	0,99	4,27
RGT= 32/90	-5	23	554,9	1895	477,6	2,59	8,85	2,23	214,2	1,10	6,39
liquid temp	0	32	666,2	2275	573,4	2,96	10,11	2,55	225,0	1,15	7,73
Tliq= 45/113	7,2	45	855,2	2921	736,0	3,62	12,37	3,12	236,2	1,20	10,05
[°C / °F]	-40	-40	76,9	263	66,2	0,68	2,33	0,59	112,9	0,71	0,95
cond. pressure	-35	-31	115,3	394	99,2	0,89	3,05	0,77	129,2	0,76	1,43
pc= 55/131	-25	-13	206,0	704	177,3	1,25	4,26	1,07	165,3	0,90	2,57
return gas temp	-15	5	324,2	1107	279,0	1,60	5,46	1,38	202,9	1,05	4,08
RGT= 32/90	-5	23	480,6	1642	413,7	2,02	6,90	1,74	237,9	1,20	6,12
liquid temp	0	32	576,5	1969	496,2	2,28	7,77	1,96	253,3	1,27	7,41
Tliq= 55/131	7,2	45	738,8	2523	635,8	2,72	9,29	2,34	271,5	1,35	9,62