

## Model

Designation	<b>KLF5.6CND</b>	<b>220-240V/50Hz 1~</b>	Sales code:	<b>106H2610</b>
-------------	------------------	-------------------------	-------------	-----------------

## Compressor design

Oil type	Polyolester	Refrigerant(s)	<b>R290</b>
Oil viscosity	10,4cSt	Displacement	5,6cm <sup>3</sup> / 0,34cu.in
Oil quantity	170cm <sup>3</sup> / 5,7fl.oz	Compressors on pallet	100
Refr. charge - tech. limit	200g / 7,1oz		
Free gas volume comp.	1605cm <sup>3</sup> / 54,3fl.oz		
Weight	9,4kg / 20,7lbs		
Motor protection	external		
Winding resistance main	10,7Ω (at 25°C)		
Winding resistance aux	17Ω (at 25°C)		
Max. winding temp.	125°C / 257°F		
Max. discharge temp.	130°C / 266°F		



## General - Configurations with KLF5.6CND

### Conf. 1

Motorconfiguration	CSIR
Power supply (nominal)	220-240V/50Hz
Number of phases	1
Voltage range	198-254V
Approvals	VDE, CCC
Starting torque	HST
Note	Electrical equipment is included and pre-assembled to compressor.

## Applications with KLF5.6CND

### Conf. 1

Refrigerant	R290
Application	LBP+MBP
System cooling	fan 3m/s
Hot gas defrost	OK
Long interval pull down	OK

## Electrical data - Configurations with KLF5.6CND

### Conf. 1

Starting device type	relay
Run capacitor	-/-
Start capacitor	80μF
LRA (locked rotor amps / 4s/ U(N))	11,4A
RLA (rated load amps / 1s/ U(N))	1,6A
Cut in current (U(N))	10,7A

## Model

Designation

**KLF5.6CND**

220-240V/50Hz 1~

Sales code:

**106H2610**

## Compressor dimensions

Housing	A Height	182mm / 7,17in
	B Height	175mm / 6,89in
	C Length shell	198mm / 7,8in
	D Length w. cover	238mm / 9,37in
	E Width	160mm / 6,3in

Connectors		Suction	Discharge	Process
		X	Y	Z
Diameter	[mm]	øi 8,11-8,29	øi 6,11-6,29	øi 6,11-6,29
(i:inside, o:outside)	[in]	øi 0,32-0,33	øi 0,24-0,25	øi 0,24-0,25
Material		copper	copper	copper
Horizontal angle	±2°	35°	13°	0°
Vertical angle	±2°	30°	40°	145°
Position l/h/w	[mm]	119/73/59	117/107/66	-88/101/71
	[in]	4,7/2,9/2,3	4,6/4,2/2,6	-3,5/4/2,8
Straight tube l.	[mm]	14	14	14
	[in]	0,5	0,5	0,5

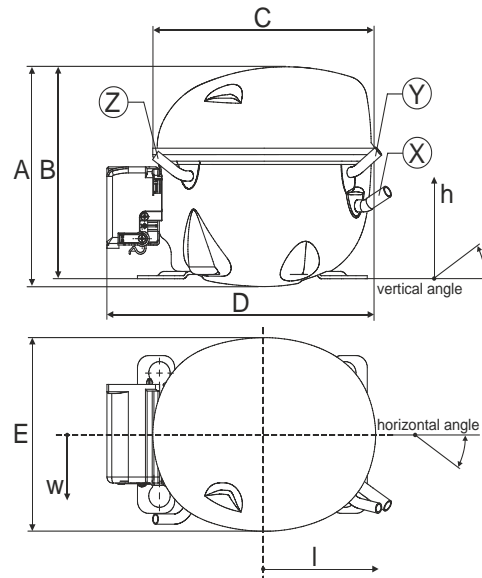

## Compressor fixation

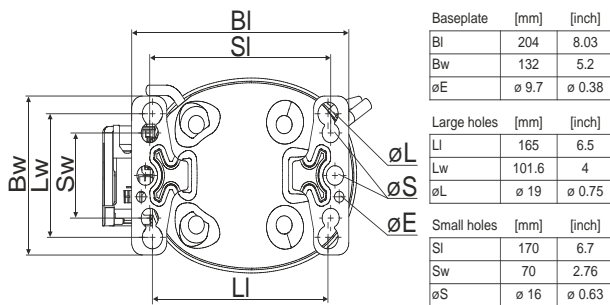

### Bolt joint

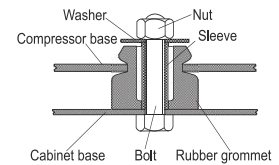

### Snap-on

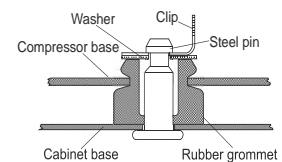

Mounting accessories	one comp.	multi pack
Bolt joint   M6   ø16mm	118-1917	118-1918
Bolt joint   ø1/4"   ø16mm	118-1946	
Bolt joint   ø1/4"   ø19mm	118-1949	
Snap-on   ø7,3   ø16mm	118-1947	118-1919

## Application notes

Operation possible until tilted up to 3 degrees

Provision for PE Grounding is located at the PE Stamp on the compressor

## Model

Designation	<b>KLF5.6CND</b>	<b>220-240V/50Hz</b>	Conf. 1	Sales code:	<b>106H2610</b>
-------------	------------------	----------------------	---------	-------------	-----------------

## Configuration

Motorconfiguration	CSIR
Power supply (nominal)	220-240V/50Hz 1~
Refrigerant	R290
Application	LBP+MBP
Voltage range	198-254V
Starting torque	HST
Approvals	VDE CCC

## Electrical accessories / wiring diagram

CSIR

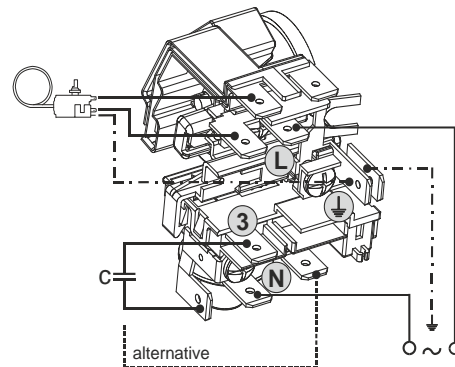
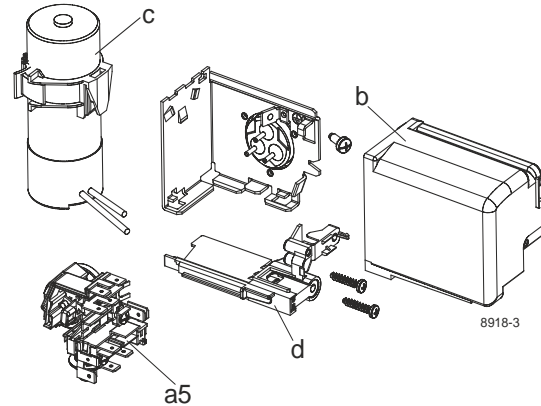

## Ambient/ machine room temperatures minimum /maximum

Ambient temperature range:	10 - 43°C / 50 - 110°F
Machine room temperature range:	10 - 48°C / 50 - 119°F
Compressor cooling:	fan 3m/s

## Operation pressure range

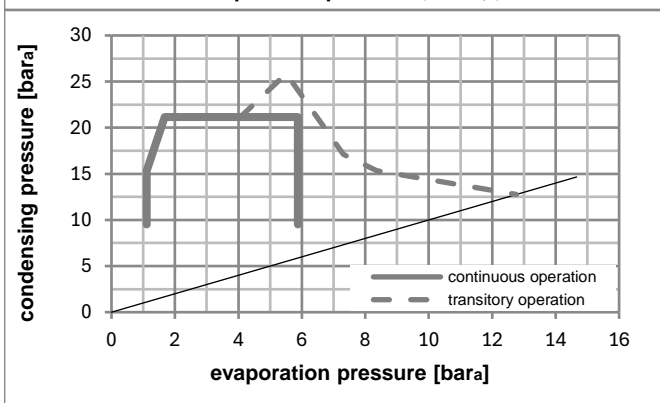
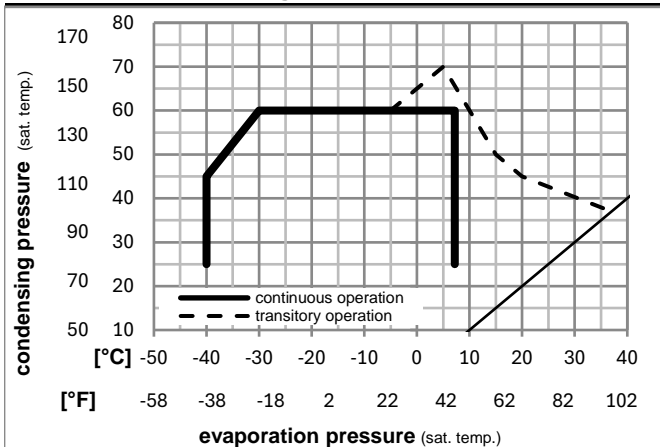

## Components (incl. and pre. assembl.)

a5	current relay (T0089/L6-S2)	117U7070
c	start capacitor (80µF, 6.3mm)	117U5001
.	cable clamp	16058100
b	cover terminal board	10636401
.	screw uni en iso 4757	10641201
.	screw - uni6954	10636000

## Alternative comp.

.	screw - uni6954	10636200
---	-----------------	----------

## Model

Designation **KLF5.6CND** **220-240V/50Hz** Conf. 1 Sales code: **106H2610**

## Optimization + standard conditions

R290, 220V/50Hz, CSIR, fan 3m/s, VDE, CCC

	Evaporating pressure (saturation temperature)				Condensing pressure (saturation temperature)			Return gas temp.	Liquid temp.	Cooling capacity	COP	EER	Power consumption		Ref. mass flow	
	pe	pc	RGT	Tliq	[W]	[Btu/h]	[kcal/h]						[W/W]	[Btu/Wh]		
[°C]	[°C]	[°C]	[°C]	[W]	[Btu/h]	[kcal/h]	[W/W]	[Btu/Wh]	[kcal/Wh]	[W]	[A]	[kg/h]				
-23	54	32	32	273,6	934	235,5	1,55	5,28	1,33	177,1	1,22	2,77	ASHRAE LBP			
-10	130	90	90													
-25	55	32	55	203,7	696	175,3	1,19	4,07	1,03	170,9	1,20	2,54	cecomaf LBP			
-13	131	90	131													
-35	40	20	40	149,1	509	128,3	1,21	4,12	1,04	123,4	1,07	1,70	EN12900 LBP			
-31	104	68	104													
-7	54	35	46	494,7	1690	425,8	2,07	7,08	1,78	238,8	1,43	5,64	ASHRAE MBP			
20	130	95	115													
-10	55	32	55	392,2	1339	337,5	1,72	5,87	1,48	228,2	1,39	4,96	cecomaf MBP			
14	131	90	131													
-10	45	20	45	435,1	1486	374,4	2,09	7,14	1,80	208,0	1,32	5,34	EN12900 MBP			
14	113	68	113													

## Performance tables

R290, 220V/50Hz, CSIR, fan 3m/s, VDE, CCC

	pe		Cooling capacity			COP	EER		P1	I	m
	[°C]	[°F]	[W]	[Btu/h]	[kcal/h]	[W/W]	[Btu/Wh]	[kcal/Wh]	[W]	[A]	[kg/h]
[°C / °F]	-35	-31	148,4	507	127,7	1,14	3,88	0,98	130,6	1,09	1,66
cond. pressure	-35	-31	148,4	507	127,7	1,14	3,88	0,98	130,6	1,09	1,66
pc= 45/113	-25	-13	241,0	823	207,4	1,49	5,08	1,28	162,1	1,17	2,72
return gas temp.	-15	5	370,8	1266	319,1	1,92	6,54	1,65	193,5	1,27	4,22
RGT= 32/90	-5	23	548,3	1872	471,9	2,48	8,47	2,14	221,0	1,36	6,31
liquid temp	0	32	658,2	2248	566,5	2,84	9,69	2,44	232,0	1,40	7,63
Tliq= 45/113	7,2	45	844,8	2885	727,1	3,47	11,85	2,99	243,5	1,45	9,93
[°C / °F]	-35	-31	114,0	389	98,1	0,86	2,92	0,74	133,3	1,10	1,41
cond. pressure	-35	-31	114,0	389	98,1	0,86	2,92	0,74	133,3	1,10	1,41
pc= 55/131	-25	-13	203,7	696	175,3	1,19	4,07	1,03	170,9	1,20	2,54
return gas temp	-15	5	320,4	1094	275,7	1,53	5,22	1,32	209,6	1,33	4,03
RGT= 32/90	-5	23	474,8	1621	408,6	1,93	6,60	1,66	245,7	1,46	6,05
liquid temp	0	32	569,4	1945	490,0	2,18	7,43	1,87	261,5	1,52	7,31
Tliq= 55/131	7,2	45	729,5	2491	627,8	2,60	8,88	2,24	280,5	1,59	9,50