

Model

Designation	KLF5.6CNDS	220-240V/50Hz 1~	Sales code:	106h2603
-------------	-------------------	------------------	-------------	-----------------

Compressor design

Oil type	Polyolester	Refrigerant(s)	R290
Oil viscosity	10,4cSt	Displacement	5,6cm ³ / 0,34cu.in
Oil quantity	174cm ³ / 5,9fl.oz	Compressors on pallet	100
Refr. charge - tech. limit	200g / 7,1oz		
Free gas volume comp.	1605cm ³ / 54,3fl.oz		
Weight	9,4kg / 20,7lbs		
Motor protection	external		
Winding resistance main	10,7Ω (at 25°C)		
Winding resistance aux	17Ω (at 25°C)		
Max. winding temp.	125°C / 257°F		
Max. discharge temp.	130°C / 266°F		
Additional note	Very good robustness against liquid intake. Ice-cube maker optimization - indirect suction intake.		



General - Configurations with KLF5.6CNDS

	Conf. 1
Motorconfiguration	CSIR
Power supply (nominal)	220-240V/50Hz
Number of phases	1
Voltage range	198-254V
Approvals	VDE, CCC
Starting torque	HST
Note	- / -

Applications with KLF5.6CNDS

	Conf. 1
Refrigerant	R290
Application	LBP+MBP
System cooling	fan 3m/s
Hot gas defrost	OK
Long interval pull down	OK

Electrical data - Configurations with KLF5.6CNDS

	Conf. 1
Starting device type	relay
Run capacitor	-/-
Start capacitor	80μF
LRA (locked rotor amps / 4s/ U(N))	11,4A
RLA (rated load amps / 1s/ U(N))	1,6A
Cut in current (U(N))	10,7A

Model

Designation	KLF5.6CNDS	220-240V/50Hz 1~	Sales code:	106h2603
-------------	-------------------	------------------	-------------	-----------------

Compressor dimensions

Housing	A Height	182mm / 7,17in
	B Height	175mm / 6,89in
	C Length shell	198mm / 7,8in
	D Length w. cover	238mm / 9,37in
	E Width	160mm / 6,3in

Connectors		Suction	Discharge	Process
		X	Y	Z
Diameter	[mm]	øi 8,11-8,29	øi 6,11-6,29	øi 6,11-6,29
(i:inside, o:outside)	[in]	øi 0,32-0,33	øi 0,24-0,25	øi 0,24-0,25
Material		copper	copper	copper
Horizontal angle	±2°	35°	13°	0°
Vertical angle	±2°	30°	40°	145°
Position l/h/w	[mm]	119/73/59	117/107/66	-88/101/71
	[in]	4,7/2,9/2,3	4,6/4,2/2,6	-3,5/4/2,8
Straight tube l.	[mm]	14	14	14
	[in]	0,5	0,5	0,5

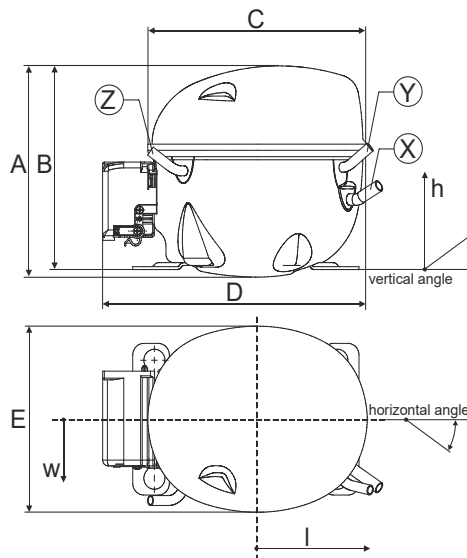

Compressor fixation



Bolt joint



Snap-on

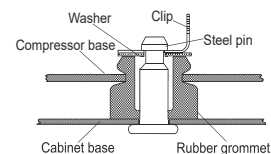

Mounting accessories	one comp.	multi pack
Bolt joint M6 ø16mm	118-1917	118-1918
Bolt joint ø1/4" ø16mm	118-1946	
Bolt joint ø1/4" ø19mm	118-1949	
Snap-on ø7,3 ø16mm	118-1947	118-1919

Application notes

Provision for PE Grounding is located at the PE Stamp on the compressor

Model

Designation	KLF5.6CNDS	220-240V/50Hz	Conf. 1	Sales code:	106h2603
-------------	-------------------	----------------------	----------------	-------------	-----------------

Configuration

Motorconfiguration	CSIR
Power supply (nominal)	220-240V/50Hz 1~
Refrigerant	R290
Application	LBP+MBP
Voltage range	198-254V
Starting torque	HST
Approvals	VDE CCC

Electrical accessories / wiring diagram

CSIR



Ambient/ machine room temperatures minimum /maximum

Ambient temperature range:	10 - 43°C / 50 - 110°F
Machine room temperature range:	10 - 48°C / 50 - 119°F
Compressor cooling:	fan 3m/s

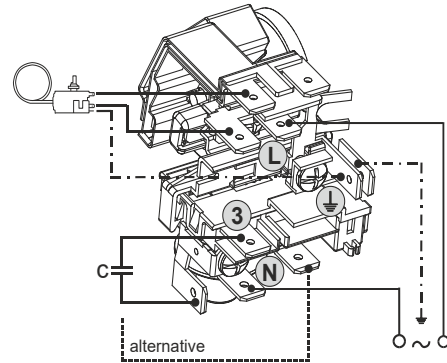

Operation pressure range

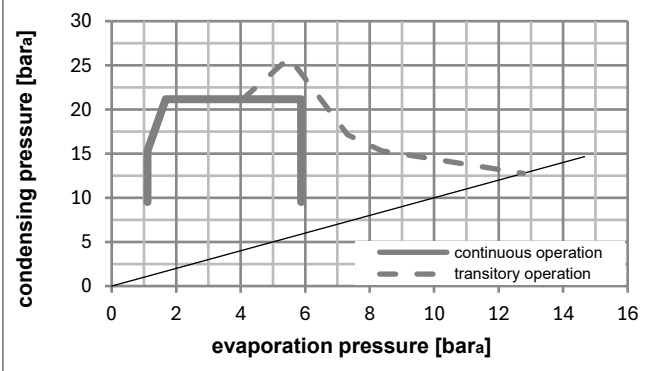
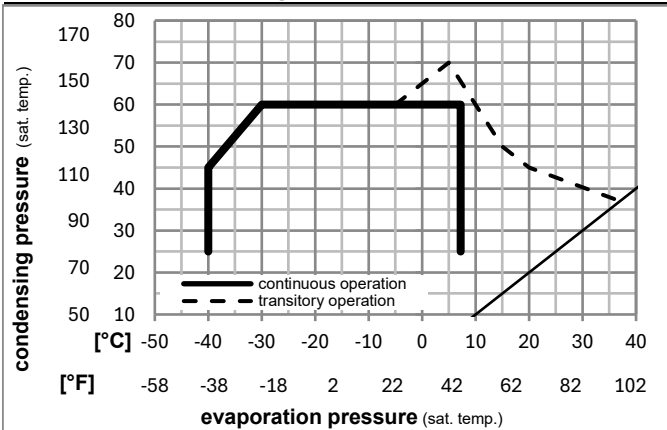

Components

a5	current relay (T0089/L6-S2)	117U7070
c	start capacitor (80µF, 6.3mm)	117U5001
b, d	cover + clamp + screws(5VA) in bag	103N1060

Alternative components

b, d	100x cover + clamp + screws(5VA)	103N2060
b, d	cover + clamp + screws(5VA-compl.)	103N0600

Model

Designation **KLF5.6CNDS 220-240V/50Hz** Conf. 1 Sales code: **106h2603**

Optimization + standard conditions

R290, 220V/50Hz, CSIR, fan 3m/s, VDE, CCC

	Evaporating pressure (saturation temperature)				Cooling capacity			COP	EER	P1	Power consumption		Ref. mass flow	
	pe	pc	RGT	Tliq	[W]	[Btu/h]	[kcal/h]				[W]	[A]		
[°C]	-23	54	32	32	264,1	902	227,3	1,51	5,14	1,30	175,3	1,21	2,67	ASHRAE LBP
[°F]	-10	130	90	90										
[°C]	-25	55	32	55	196,6	671	169,2	1,16	3,97	1,00	169,2	1,19	2,45	cecomaf LBP
[°F]	-13	131	90	131										
[°C]	-35	40	20	40	143,9	491	123,8	1,18	4,02	1,01	122,2	1,06	1,64	EN12900 LBP
[°F]	-31	104	68	104										
[°C]	-7	54	35	46	477,4	1631	410,9	2,02	6,90	1,74	236,4	1,42	5,45	ASHRAE MBP
[°F]	20	130	95	115										
[°C]	-10	55	32	55	378,5	1293	325,7	1,67	5,72	1,44	226,0	1,38	4,79	cecomaf MBP
[°F]	14	131	90	131										
[°C]	-10	45	20	45	419,9	1434	361,3	2,04	6,96	1,75	205,9	1,31	5,16	EN12900 MBP
[°F]	14	113	68	113										

Performance tables

R290, 220V/50Hz, CSIR, fan 3m/s, VDE, CCC

	pe		Cooling capacity			COP	EER	P1	I	m	
	[°C]	[°F]	[W]	[Btu/h]	[kcal/h]						[W/W]
[°C / °F]	-40	-40	108,7	371	93,5	0,95	3,23	0,81	114,9	1,05	1,22
cond. pressure	-35	-31	143,2	489	123,2	1,11	3,78	0,95	129,3	1,08	1,60
pc= 45/113	-25	-13	232,6	794	200,2	1,45	4,95	1,25	160,5	1,16	2,62
return gas temp.	-15	5	357,8	1222	308,0	1,87	6,38	1,61	191,6	1,26	4,07
RGT= 32/90	-5	23	529,1	1807	455,4	2,42	8,26	2,08	218,8	1,35	6,09
liquid temp	0	32	635,2	2169	546,7	2,77	9,44	2,38	229,7	1,39	7,37
Tliq= 45/113	7,2	45	815,3	2784	701,7	3,38	11,55	2,91	241,1	1,43	9,58
[°C / °F]	-40	-40	73,4	251	63,2	0,64	2,18	0,55	115,0	1,05	0,90
cond. pressure	-35	-31	110,0	376	94,7	0,83	2,85	0,72	132,0	1,08	1,36
pc= 55/131	-25	-13	196,6	671	169,2	1,16	3,97	1,00	169,2	1,19	2,45
return gas temp	-15	5	309,2	1056	266,1	1,49	5,09	1,28	207,6	1,31	3,89
RGT= 32/90	-5	23	458,2	1565	394,3	1,88	6,43	1,62	243,3	1,44	5,84
liquid temp	0	32	549,5	1877	472,9	2,12	7,25	1,83	259,0	1,50	7,06
Tliq= 55/131	7,2	45	704,0	2404	605,9	2,53	8,66	2,18	277,7	1,57	9,17