

Model

Designation	KLF5.6CNH	115-127V/60Hz 1~	Sales code:	106H3601
-------------	------------------	------------------	-------------	-----------------

Compressor design

Oil type	Polyolester	Refrigerant(s)	R290
Oil viscosity	9,7cST	Displacement	5,6cm ³ / 0,34cu.in
Oil quantity	170cm ³ / 5,7fl.oz	Compressors on pallet	100
Refr. charge - tech. limit	200g / 7,1oz		
Free gas volume comp.	1605cm ³ / 54,3fl.oz		
Weight	9,5kg / 20,9lbs		
Motor protection	external		
Winding resistance main	2Ω (at 25°C)		
Winding resistance aux	5,3Ω (at 25°C)		
Max. winding temp.	125°C / 257°F		
Max. discharge temp.	130°C / 266°F		



General - Configurations with KLF5.6CNH

	Conf. 1	Conf. 2
Motorconfiguration	CSIR	RSCR
Power supply (nominal)	115-127V/60Hz	115-127V/60Hz
Number of phases	1	1
Voltage range	95-140V	95-140V
Approvals	UL, CCC	UL, CCC
Starting torque	HST	LST
Note	- / -	

Applications with KLF5.6CNH

	Conf. 1	Conf. 2
Refrigerant	R290	R290
Application	LBP+MBP	LBP+MBP
System cooling	fan 3m/s	fan 3m/s
Hot gas defrost	OK	OK
Long interval pull down	OK	OK

Electrical data - Configurations with KLF5.6CNH

	Conf. 1	Conf. 2
Starting device type	relay	PTC
Run capacitor	-/-	15μF
Start capacitor	240μF	-/-
LRA (locked rotor amps / 4s/ U(N))	31,1A	31,1A
RLA (rated load amps / 1s/ U(N))	4,3A	4,3A
Cut in current (U(N))	27,8A	31,5A

Model

Designation	KLF5.6CNH	115-127V/60Hz 1~	Sales code:	106H3601
-------------	------------------	------------------	-------------	-----------------

Compressor dimensions

Housing	A Height	182mm / 7,17in
	B Height	175mm / 6,89in
	C Length shell	198mm / 7,8in
	D Length w. cover	238mm / 9,37in
	E Width	160mm / 6,3in

Connectors		Suction	Discharge	Process
		X	Y	Z
Diameter	[mm]	øi 8,11-8,29	øi 6,41-6,59	øi 6,41-6,59
	(i:inside, o:outside) [in]	øi 0,32-0,33	øi 0,25-0,26	øi 0,25-0,26
Material		copper	copper	copper
Horizontal angle	±2°	35°	13°	0°
Vertical angle	±2°	30°	40°	145°
Position l/h/w	[mm]	120/72/57	112/106/81	-97/94/72
	[in]	4,7/2,8/2,2	4,4/4,2/3,2	-3,8/3,7/2,8
Straight tube l.	[mm]	14	14	14
	[in]	0,5	0,5	0,5

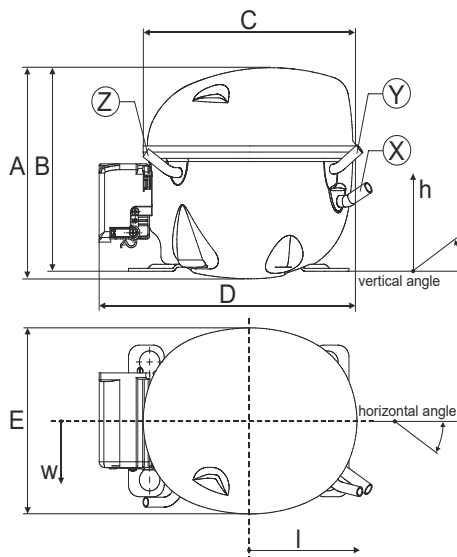

Compressor fixation

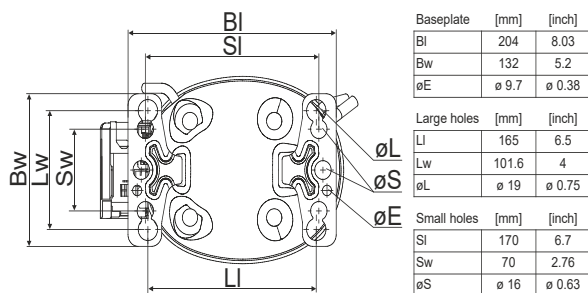

Bolt joint

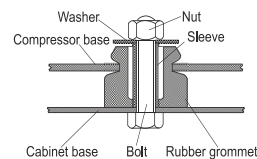

Snap-on

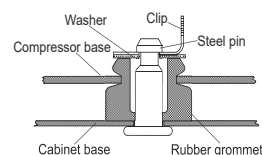

Mounting accessories	one comp.	multi pack
Bolt joint M6 ø16mm	118-1917	118-1918
Bolt joint ø1/4" ø16mm	118-1946	
Bolt joint ø1/4" ø19mm	118-1949	
Snap-on ø7,3 ø16mm	118-1947	118-1919

Application notes

Provision for PE Grounding is located at the PE Stamp on the compressor

Model

Designation	KLF5.6CNH	115-127V/60Hz	Conf. 1	Sales code:	106H3601
-------------	------------------	----------------------	---------	-------------	-----------------

Configuration

Motorconfiguration	CSIR
Power supply (nominal)	115-127V/60Hz 1~
Refrigerant	R290
Application	LBP+MBP
Voltage range	95-140V
Starting torque	HST
Approvals	UL CCC

Electrical accessories / wiring diagram

CSIR

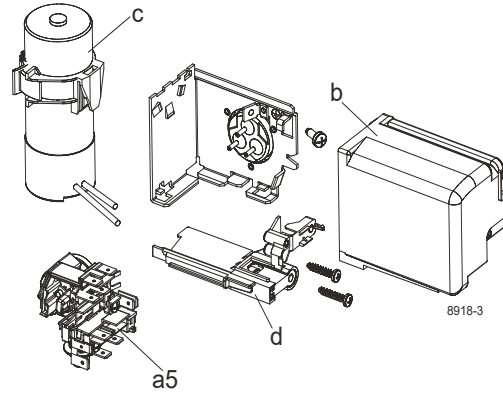

Ambient/ machine room temperatures minimum /maximum

Ambient temperature range:	10 - 43°C / 50 - 110°F
Machine room temperature range:	10 - 48°C / 50 - 119°F
Compressor cooling:	fan 3m/s

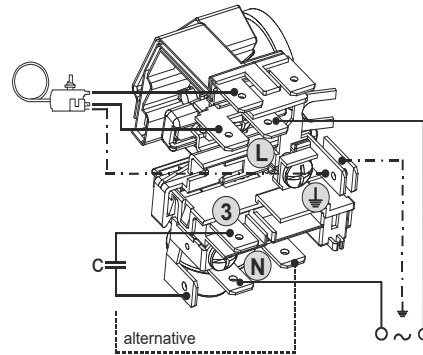

Operation pressure range

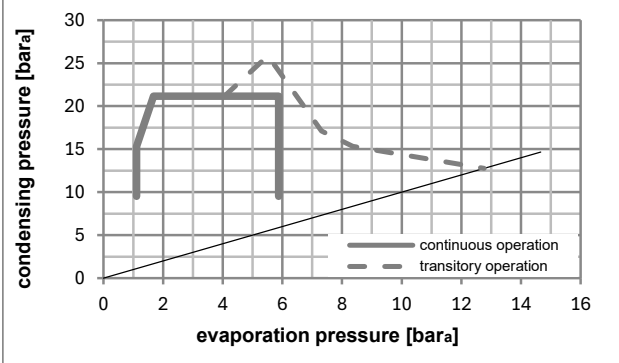
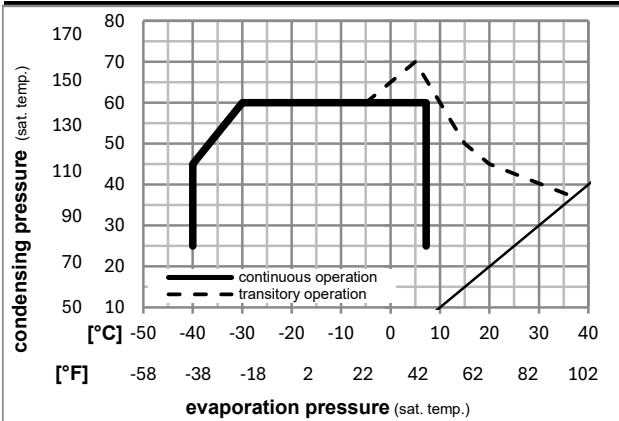

Components

a5	current relay (T1217/L6-S5)	117U7075
c	start capacitor (240µF)	117U5002
b, d	cover + clamp + screws(5VA) in bag	103N1060

Alternative components

b, d	100x cover + clamp + screws(5VA)	103N2060
b, d	cover + clamp + screws(5VA-compl.)	103N0600

Model

Designation **KLF5.6CNH** **115-127V/60Hz** Conf. 1 Sales code: **106H3601**

Optimization + standard conditions

R290, 115V/60Hz, CSIR, fan 3m/s, UL, CCC

Evaporating pressure (saturation temperature)				Condensing pressure (saturation temperature)			Power consumption				Current consumption		Ref. mass flow ṁ	
pe	pc	RGT	Tliq	Cooling capacity	COP	EER	P1	I						
[°C]	[°C]	[°C]	[°C]	[W]	[Btu/h]	[kcal/h]	[W/W]	[Btu/Wh]	[kcal/Wh]	[W]	[A]	[kg/h]		
[°C]	-23	54	32	32	338,8	1157	291,6	1,61	5,49	1,38	210,8	2,78	3,43	ASHRAE LBP
[°F]	-10	130	90	90										
[°C]	-25	55	32	55	253,9	867	218,5	1,26	4,29	1,08	202,3	2,73	3,16	cecomaf LBP
[°F]	-13	131	90	131										
[°C]	-35	40	20	40	189,6	648	163,2	1,25	4,26	1,07	152,2	2,47	2,17	EN12900 LBP
[°F]	-31	104	68	104										
[°C]	-7	54	35	46	609,1	2080	524,2	2,11	7,20	1,81	289,1	3,28	6,95	ASHRAE MBP
[°F]	20	130	95	115										
[°C]	-10	55	32	55	483,5	1651	416,1	1,75	5,98	1,51	276,0	3,19	6,12	cecomaf MBP
[°F]	14	131	90	131										
[°C]	-10	45	20	45	537,8	1837	462,9	2,14	7,30	1,84	251,6	3,03	6,60	EN12900 MBP
[°F]	14	113	68	113										

Performance tables

R290, 115V/60Hz, CSIR, fan 3m/s, UL, CCC

	pe		Cooling capacity			COP	EER	P1	I	m	
	[°C]	[°F]	[W]	[Btu/h]	[kcal/h]	[W/W]	[Btu/Wh]	[kcal/Wh]	[W]	[A]	[kg/h]
[°C / °F]	-40	-40	140,6	480	121,0	1,03	3,53	0,89	135,9	2,41	1,57
cond. pressure	-34	-30	187,4	640	161,3	1,19	4,07	1,03	157,1	2,49	2,10
pc= 45/113	-23	-10	321,5	1098	276,7	1,59	5,44	1,37	202,0	2,72	3,63
return gas temp.	-15	5	460,1	1571	396,0	1,96	6,71	1,69	234,3	2,91	5,23
RGT= 32/90	-4	25	699,7	2390	602,2	2,60	8,87	2,23	269,5	3,15	8,07
liquid temp	0	32	799,2	2729	687,8	2,87	9,80	2,47	278,5	3,21	9,27
Tliq= 45/113	7,2	45	1006,7	3438	866,4	3,48	11,89	3,00	289,1	3,29	11,83
[°C / °F]	-40	-40	123,2	421	106,0	0,97	3,31	0,83	127,3	2,37	1,52
cond. pressure	-34	-30	160,9	549	138,5	1,04	3,57	0,90	154,1	2,48	1,99
pc= 55/131	-23	-10	274,3	937	236,1	1,30	4,44	1,12	210,9	2,78	3,42
return gas temp.	-15	5	395,2	1350	340,1	1,56	5,34	1,35	252,7	3,04	4,97
RGT= 32/90	-4	25	608,4	2078	523,6	2,02	6,89	1,74	301,4	3,37	7,76
liquid temp	0	32	697,8	2383	600,6	2,21	7,56	1,90	315,4	3,48	8,96
Tliq= 55/131	7,2	45	885,6	3024	762,1	2,64	9,02	2,27	335,3	3,63	11,54

Model

Designation	KLF5.6CNH	115-127V/60Hz	Conf. 2	Sales code:	106H3601
-------------	------------------	----------------------	----------------	-------------	-----------------

Configuration

Motorconfiguration	RSCR
Power supply (nominal)	115-127V/60Hz 1~
Refrigerant	R290
Application	LBP+MBP
Voltage range	95-140V
Starting torque	LST
Approvals	UL CCC

Electrical accessories / wiring diagram

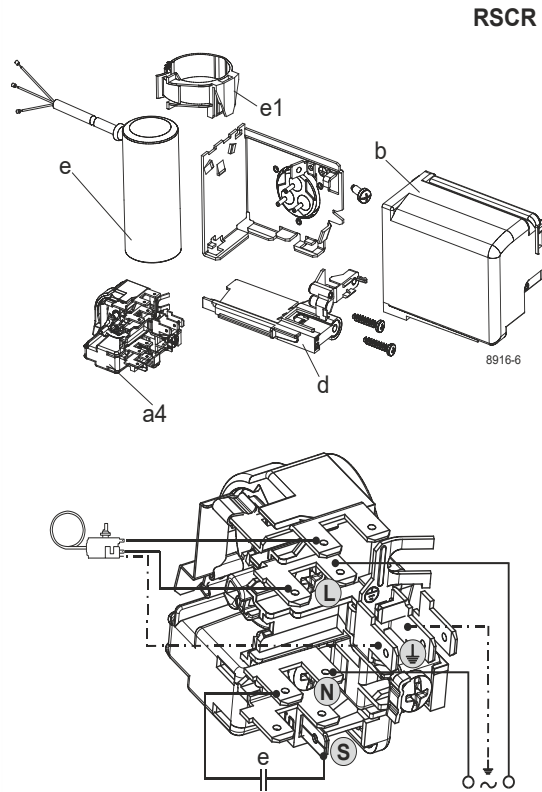

Ambient/ machine room temperatures minimum /maximum

Ambient temperature range:	10 - 43°C / 50 - 110°F
Machine room temperature range:	10 - 48°C / 50 - 119°F
Compressor cooling:	fan 3m/s

Operation pressure range

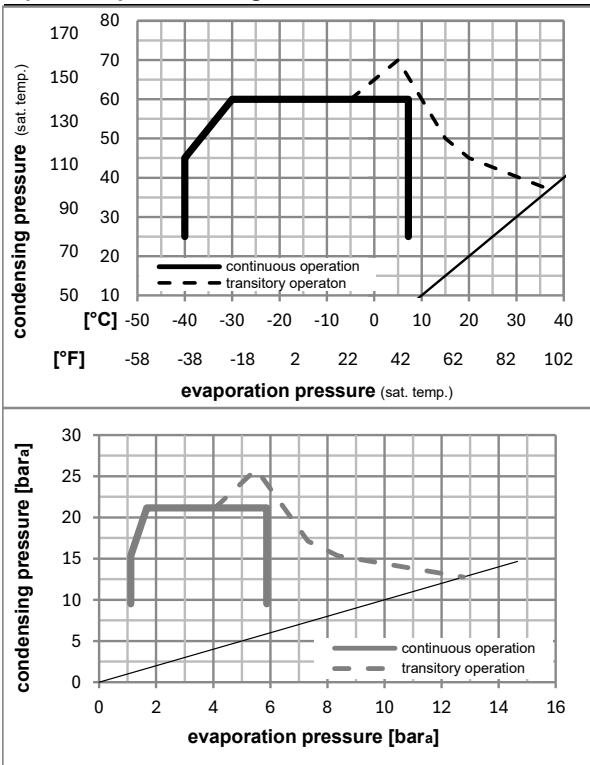

Components

a4	DLS5 (PTC,6.3mm, T1217/L6 - S5)	103N0212
e	run capacitor (15μF, 6,3mm)	117-7153
b, d	cover + clamp + screws(5VA) in bag	103N1060
e1	retaining clamp	103N0535

Alternative components

b, d	100x cover + clamp + screws(5VA)	103N2060
b, d	cover + clamp + screws(5VA-compl.)	103N0600

Model

Designation	KLF5.6CNH	115-127V/60Hz	Conf. 2	Sales code:	106H3601
-------------	------------------	----------------------	----------------	-------------	-----------------

Optimization + standard conditions

R290, 115V/60Hz, RSCR, fan 3m/s, UL, CCC

		Evaporating pressure (saturation temperature)				Condensing pressure (saturation temperature)						Power consumption					
		Return gas temp.		Liquid temp.		Cooling capacity		COP	EER		P1	I	Ref. mass flow				
		pe	pc	RGT	Tliq	[W]	[Btu/h]	[kcal/h]	[W/W]	[Btu/Wh]	[kcal/Wh]	[W]	[A]	[kg/h]			
[°C]	[°F]	[°C]	[°F]	[°C]	[°F]												
-23	-10	54	130	32	90	32	90	346,8	1184	298,5	1,69	5,77	1,46	205,1	2,06	3,51	ASHRAE LBP
-25	-13	55	131	32	90	55	131	260,4	889	224,1	1,32	4,52	1,14	196,9	2,00	3,24	cecomaf LBP
-35	-31	40	104	20	68	40	104	189,4	647	163,0	1,28	4,38	1,10	147,5	1,65	2,16	EN12900 LBP
-7	20	54	130	35	95	46	115	613,4	2095	527,9	2,19	7,48	1,88	280,2	2,66	7,00	ASHRAE MBP
-10	14	55	131	32	90	55	131	487,6	1665	419,7	1,82	6,23	1,57	267,5	2,56	6,17	cecomaf MBP
-10	14	45	113	20	68	45	113	535,1	1828	460,6	2,21	7,53	1,90	242,6	2,36	6,57	EN12900 MBP

Performance tables

R290, 115V/60Hz, RSCR, fan 3m/s, UL, CCC

	pe		Cooling capacity			COP	EER	P1	I	m	
	[°C]	[°F]	[W]	[Btu/h]	[kcal/h]	[W/W]	[Btu/Wh]				[kcal/Wh]
[°C / °F]	-40	-40	140,1	478	120,6	1,06	3,63	0,91	131,9	1,55	1,57
cond. pressure	-34	-30	189,5	647	163,1	1,24	4,23	1,07	152,9	1,69	2,12
pc= 45/113	-23	-10	322,7	1102	277,7	1,65	5,63	1,42	195,7	1,99	3,64
return gas temp.	-15	5	458,5	1566	394,6	2,03	6,93	1,75	226,1	2,23	5,22
RGT= 32/90	-4	25	696,9	2380	599,8	2,68	9,15	2,31	260,1	2,50	8,04
liquid temp	0	32	797,8	2725	686,6	2,96	10,11	2,55	269,4	2,57	9,25
Tliq= 45/113	7,2	45	1011,7	3455	870,7	3,59	12,25	3,09	281,9	2,68	11,89
[°C / °F]	-40	-40	121,9	416	104,9	0,99	3,37	0,85	123,7	1,47	1,50
cond. pressure	-34	-30	164,7	562	141,7	1,10	3,74	0,94	150,3	1,66	2,04
pc= 55/131	-23	-10	280,7	959	241,6	1,37	4,67	1,18	205,2	2,06	3,50
return gas temp	-15	5	400,2	1367	344,5	1,63	5,58	1,41	245,1	2,38	5,03
RGT= 32/90	-4	25	612,4	2091	527,0	2,09	7,15	1,80	292,5	2,77	7,81
liquid temp	0	32	702,8	2400	604,8	2,29	7,83	1,97	306,7	2,88	9,03
Tliq= 55/131	7,2	45	895,6	3059	770,8	2,73	9,31	2,35	328,6	3,07	11,67