

Model

Designation	KLF5.6CNHS	115-127V/60Hz 1~	Sales code:	106H3603
-------------	-------------------	------------------	-------------	-----------------

Compressor design

Oil type	Polyolester	Refrigerant(s)	R290
Oil viscosity	10,4cSt	Displacement	5,6cm ³ / 0,34cu.in
Oil quantity	170cm ³ / 5,7fl.oz	Compressors on pallet	100
Refr. charge - tech. limit	200g / 7,1oz		
Free gas volume comp.	1605cm ³ / 54,3fl.oz		
Weight	9,5kg / 20,9lbs		
Motor protection	external		
Winding resistance main	2Ω (at 25°C)		
Winding resistance aux	5,3Ω (at 25°C)		
Max. winding temp.	125°C / 257°F		
Max. discharge temp.	130°C / 266°F		
Additional note	Very good robustness against liquid intake. Ice-cube maker optimization - indirect suction intake.		



General - Configurations with KLF5.6CNHS

Conf. 1

Motorconfiguration	CSIR
Power supply (nominal)	115-127V/60Hz
Number of phases	1
Voltage range	95-140V
Approvals	UL, CCC
Starting torque	HST
Note	- / -

Applications with KLF5.6CNHS

Conf. 1

Refrigerant	R290
Application	LBP+MBP
System cooling	fan 3m/s
Hot gas defrost	OK
Long interval pull down	OK

Electrical data - Configurations with KLF5.6CNHS

Conf. 1

Starting device type	relay
Run capacitor	-/-
Start capacitor	240μF
LRA (locked rotor amps / 4s/ U(N))	31,1A
RLA (rated load amps / 1s/ U(N))	4,3A
Cut in current (U(N))	27,8A

Model

Designation

KLF5.6CNHS

115-127V/60Hz 1~

Sales code:

106H3603

Compressor dimensions

Housing	A Height	182mm / 7,17in
	B Height	175mm / 6,89in
	C Length shell	198mm / 7,8in
	D Length w. cover	238mm / 9,37in
	E Width	160mm / 6,3in

Connectors		Suction	Discharge	Process
		X	Y	Z
Diameter	[mm]	øi 8,11-8,29	øi 6,41-6,59	øi 6,41-6,59
(i:inside, o:outside)	[in]	øi 0,32-0,33	øi 0,25-0,26	øi 0,25-0,26
Material		copper	copper	copper
Horizontal angle	±2°	35°	13°	0°
Vertical angle	±2°	30°	40°	145°
Position l/h/w	[mm]	119/73/59	117/107/66	-88/101/71
	[in]	4,7/2,9/2,3	4,6/4,2/2,6	-3,5/4/2,8
Straight tube l.	[mm]	14	14	14
	[in]	0,5	0,5	0,5

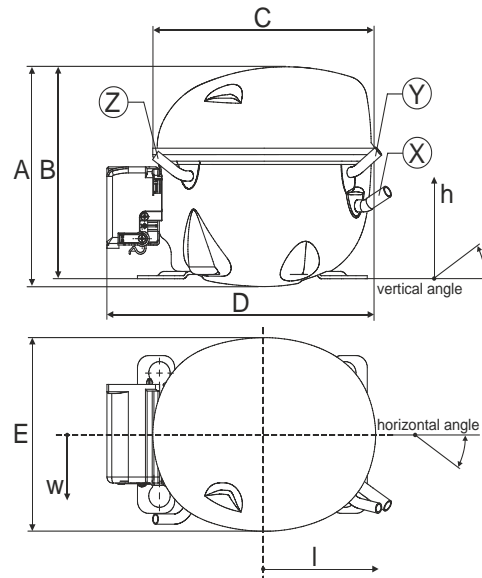

Compressor fixation

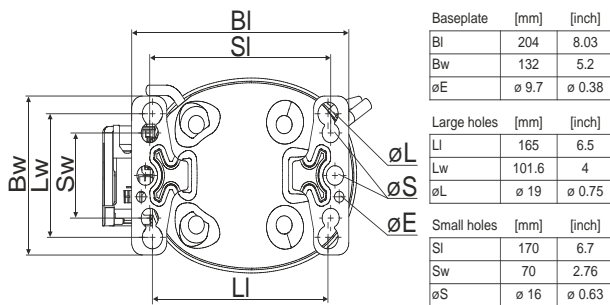

Bolt joint

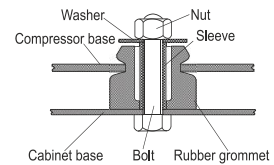

Snap-on

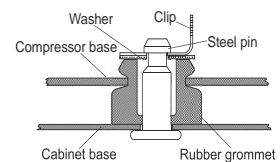

Mounting accessories	one comp.	multi pack
Bolt joint M6 ø16mm	118-1917	118-1918
Bolt joint ø1/4" ø16mm	118-1946	
Bolt joint ø1/4" ø19mm	118-1949	
Snap-on ø7,3 ø16mm	118-1947	118-1919

Application notes

Provision for PE Grounding is located at the PE Stamp on the compressor

Model

Designation **KLF5.6CNHS** **115-127V/60Hz** Conf. 1 Sales code: **106H3603**

Configuration

Motorconfiguration CSIR
 Power supply (nominal) 115-127V/60Hz 1~
 Refrigerant R290
 Application LBP+MBP
 Voltage range 95-140V
 Starting torque HST
 Approvals UL
 CCC

Electrical accessories / wiring diagram

CSIR



Ambient/ machine room temperatures minimum /maximum

Ambient temperature range: 10 - 43°C / 50 - 110°F

Machine room temperature range: 10 - 48°C / 50 - 119°F

Compressor cooling: fan 3m/s



Operation pressure range

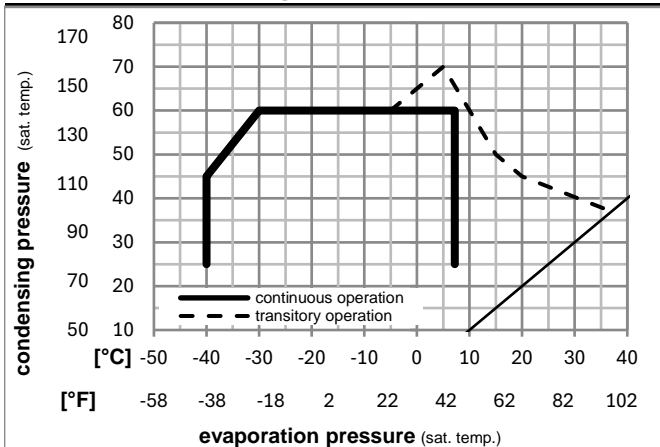

Components

a5	current relay (T1217/L6-S5)	117U7075
c	start capacitor (240µF)	117U5002
b, d	cover + clamp + screws(5VA-compl.)	103N0600

Alternative components

b, d	100x cover + clamp + screws(5VA)	103N2060
b, d	cover + clamp + screws(5VA) in bag	103N1060

Model

Designation **KLF5.6CNHS 115-127V/60Hz** Conf. 1 Sales code: **106H3603**

Optimization + standard conditions

R290, 115V/60Hz, CSIR, fan 3m/s, UL, CCC

		Evaporating pressure (saturation temperature)				Condensing pressure (saturation temperature)			Return gas temp.			Liquid temp.		Cooling capacity			COP	EER	Power consumption			ASHRAE LBP
		pe	pc	RGT	Tliq	[W]	[Btu/h]	[kcal/h]	[W/W]	[Btu/Wh]	[kcal/Wh]	P1	I	Ref. mass flow				ASHRAE LBP				
[°C]	[°F]	[°C]	[°F]	[°C]	[°F]	[W]	[Btu/h]	[kcal/h]	[W/W]	[Btu/Wh]	[kcal/Wh]	[W]	[A]	[kg/h]								
[°C]	-23	54	32	32	326,8	1116	281,3	1,57	5,35	1,35	208,7	2,75	3,31									
[°F]	-10	130	90	90																		
[°C]	-25	55	32	55	245,0	837	210,8	1,22	4,18	1,05	200,3	2,70	3,05				cecomaf LBP					
[°F]	-13	131	90	131																		
[°C]	-35	40	20	40	182,9	625	157,4	1,21	4,15	1,05	150,6	2,44	2,09				EN12900 LBP					
[°F]	-31	104	68	104																		
[°C]	-7	54	35	46	587,6	2007	505,7	2,05	7,01	1,77	286,1	3,25	6,70				ASHRAE MBP					
[°F]	20	130	95	115																		
[°C]	-10	55	32	55	466,5	1593	401,5	1,71	5,83	1,47	273,2	3,16	5,90				cecomaf MBP					
[°F]	14	131	90	131																		
[°C]	-10	45	20	45	518,9	1772	446,5	2,08	7,11	1,79	249,1	3,00	6,37				EN12900 MBP					
[°F]	14	113	68	113																		

Performance tables

R290, 115V/60Hz, CSIR, fan 3m/s, UL, CCC

	pe		Cooling capacity			COP	EER		P1	I	m
	[°C]	[°F]	[W]	[Btu/h]	[kcal/h]	[W/W]	[Btu/Wh]	[kcal/Wh]	[W]	[A]	[kg/h]
[°C / °F]	-34	-30	180,8	617	155,6	1,16	3,97	1,00	155,5	2,47	2,03
cond. pressure	-34	-30	180,8	617	155,6	1,16	3,97	1,00	155,5	2,47	2,03
pc= 45/113	-23	-10	310,2	1059	266,9	1,55	5,30	1,34	199,9	2,69	3,50
return gas temp.	-15	5	443,9	1516	382,0	1,91	6,54	1,65	231,9	2,88	5,05
RGT= 32/90	-4	25	675,0	2305	580,9	2,53	8,64	2,18	266,8	3,12	7,78
liquid temp	0	32	771,1	2633	663,6	2,80	9,55	2,41	275,7	3,18	8,94
Tliq= 45/113	7,2	45	971,2	3317	835,8	3,39	11,59	2,92	286,1	3,26	11,41
[°C / °F]	-34	-30	155,2	530	133,6	1,02	3,48	0,88	152,5	2,45	1,92
cond. pressure	-34	-30	155,2	530	133,6	1,02	3,48	0,88	152,5	2,45	1,92
pc= 55/131	-23	-10	264,7	904	227,8	1,27	4,33	1,09	208,8	2,75	3,30
return gas temp	-15	5	381,3	1302	328,2	1,52	5,21	1,31	250,1	3,01	4,79
RGT= 32/90	-4	25	586,9	2004	505,1	1,97	6,72	1,69	298,4	3,34	7,49
liquid temp	0	32	673,2	2299	579,4	2,16	7,37	1,86	312,2	3,44	8,65
Tliq= 55/131	7,2	45	854,3	2918	735,2	2,57	8,79	2,22	331,9	3,60	11,13