

Model

| | | | | |
|-------------|------------------|-----------------------------------|-------------|-----------------|
| Designation | KLF5.6CNT | 200-240V/50Hz 1~ 208-230V/60Hz 1~ | Sales code: | 106H2602 |
|-------------|------------------|-----------------------------------|-------------|-----------------|

Compressor design

| | | | |
|----------------------------|---------------------------------|-----------------------|--------------------------------|
| Oil type | Polyolester | Refrigerant(s) | R290 |
| Oil viscosity | 19,2cST | Displacement | 5,6cm ³ / 0,34cu.in |
| Oil quantity | 162cm ³ / 5,5fl.oz | Compressors on pallet | 100 |
| Refr. charge - tech. limit | 200g / 7,1oz | | |
| Free gas volume comp. | 1605cm ³ / 54,3fl.oz | | |
| Weight | 9,4kg / 20,7lbs | | |
| Motor protection | external | | |
| Winding resistance main | 10,7Ω (at 25°C) | | |
| Winding resistance aux | 17Ω (at 25°C) | | |
| Max. winding temp. | 125°C / 257°F | | |
| Max. discharge temp. | 130°C / 266°F | | |



General - Configurations with KLF5.6CNT

| | Conf. 1 | Conf. 2 | Conf. 3 | Conf. 4 |
|------------------------|-------------------------|-------------------------|-------------------------|-------------------------|
| Motorconfiguration | CSIR | RSCR | CSIR | RSCR |
| Power supply (nominal) | 200-240V/50Hz | 200-240V/50Hz | 208-230V/60Hz | 208-230V/60Hz |
| Number of phases | 1 | 1 | 1 | 1 |
| Voltage range | 187-254V | 187-254V | 198-253V | 198-253V |
| Approvals | UL, CCC, CB under prep. | UL, CCC, CB under prep. | UL, CCC, CB under prep. | UL, CCC, CB under prep. |
| Starting torque | HST | LST | HST | LST |
| Note | - / - | | | |

Applications with KLF5.6CNT

| | Conf. 1 | Conf. 2 | Conf. 3 | Conf. 4 |
|-------------------------|----------------|----------------|----------------|----------------|
| Refrigerant | R290 | R290 | R290 | R290 |
| Application | LBP+MBP | LBP+MBP | LBP+MBP | LBP+MBP |
| System cooling | fan 3m/s | fan 3m/s | fan 3m/s | fan 3m/s |
| Hot gas defrost | OK | OK | OK | OK |
| Long interval pull down | OK | OK | -/- | -/- |

Electrical data - Configurations with KLF5.6CNT

| | Conf. 1 | Conf. 2 | Conf. 3 | Conf. 4 |
|------------------------------|----------------|----------------|----------------|----------------|
| Starting device type | relay | PTC | relay | PTC |
| Run capacitor | -/- | 5μF | -/- | 5μF |
| Start capacitor | 80μF | -/- | 80μF | -/- |
| LRA (locked rotor amps / 4s) | 10,3A | 8,6A | 10,3A | 8,6A |
| RLA (rated load amps / 1s) | 1,7A | 1,7A | 1,7A | 1,7A |
| Cut in current | 10,3A | 15,5A | 10,3A | 15,5A |

Model

Designation

KLF5.6CNT

200-240V/50Hz 1~ 208-230V/60Hz 1~

Sales code:

106H2602

Compressor dimensions

| Housing | A Height | 182mm / 7,17in |
|---------|-------------------|----------------|
| | B Height | 175mm / 6,89in |
| | C Length shell | 198mm / 7,8in |
| | D Length w. cover | 238mm / 9,37in |
| | E Width | 160mm / 6,3in |

| Connectors | | Suction | Discharge | Process |
|------------------|----------------------------|--------------|--------------|--------------|
| | | X | Y | Z |
| Diameter | [mm] | øi 8,11-8,29 | øi 6,11-6,29 | øi 6,11-6,29 |
| | (i:inside, o:outside) [in] | øi 0,32-0,33 | øi 0,24-0,25 | øi 0,24-0,25 |
| Material | | copper | copper | copper |
| Horizontal angle | ±2° | 35° | 13° | 0° |
| Vertical angle | ±2° | 30° | 40° | 145° |
| Position l/h/w | [mm] | 120/72/62 | 112/106/62 | -97/102/70 |
| | [in] | 4,7/2,8/2,4 | 4,4/4,2/2,4 | -3,8/4/2,8 |
| Straight tube l. | [mm] | 14 | 14 | 14 |
| | [in] | 0,5 | 0,5 | 0,5 |

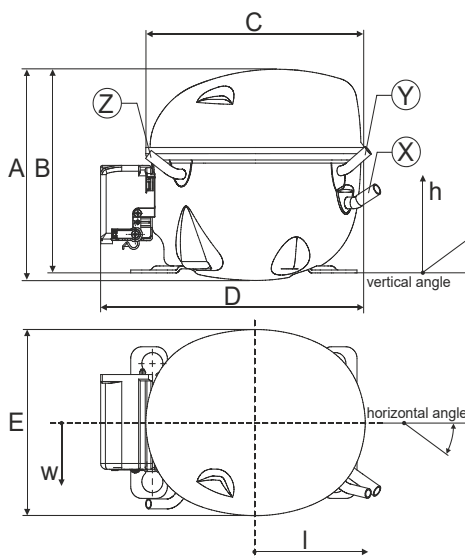

Compressor fixation

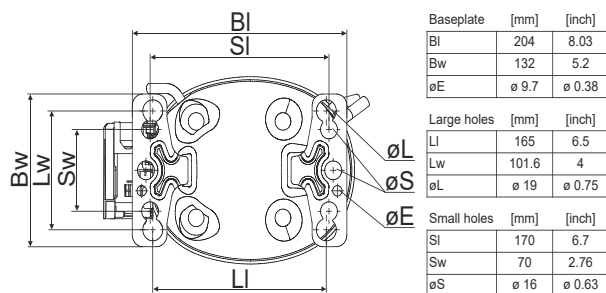

Bolt joint



Snap-on

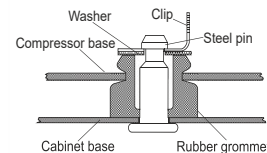

Mounting accessories

| Mounting accessories | one comp. | multi pack |
|----------------------------|-----------|------------|
| Bolt joint M6 ø16mm | 118-1917 | 118-1918 |
| Bolt joint ø1/4" ø16mm | 118-1946 | |
| Bolt joint ø1/4" ø19mm | 118-1949 | |
| Snap-on ø7,3 ø16mm | 118-1947 | 118-1919 |

Application notes

LRA value on compressor label and datasheet may differ due to different test conditions for UL approval.

Provision for PE Grounding is located at the PE Stamp on the compressor

Model

| | | | | | |
|-------------|------------------|----------------------|----------------|-------------|-----------------|
| Designation | KLF5.6CNT | 200-240V/50Hz | Conf. 1 | Sales code: | 106H2602 |
|-------------|------------------|----------------------|----------------|-------------|-----------------|

Configuration

| | |
|------------------------|------------------|
| Motorconfiguration | CSIR |
| Power supply (nominal) | 200-240V/50Hz 1~ |
| Refrigerant | R290 |
| Application | LBP+MBP |
| Voltage range | 187-254V |
| Starting torque | HST |
| Approvals | UL |
| | CCC |
| | CB under prep. |

Electrical accessories / wiring diagram

CSIR

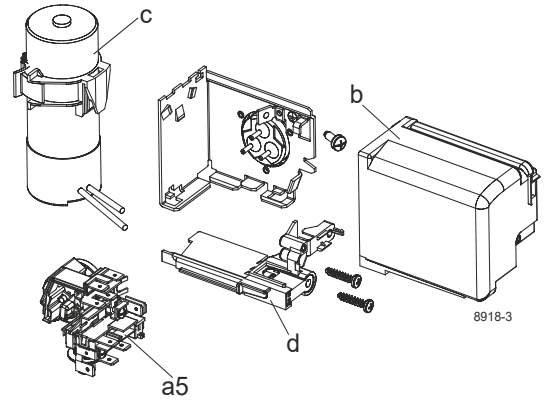

Ambient/ machine room temperatures minimum /maximum

| | |
|---------------------------------|------------------------|
| Ambient temperature range: | 10 - 43°C / 50 - 110°F |
| Machine room temperature range: | 10 - 48°C / 50 - 119°F |

Compressor cooling: fan 3m/s

Compressor with external protector. For max. operation envelope cooling on protector.

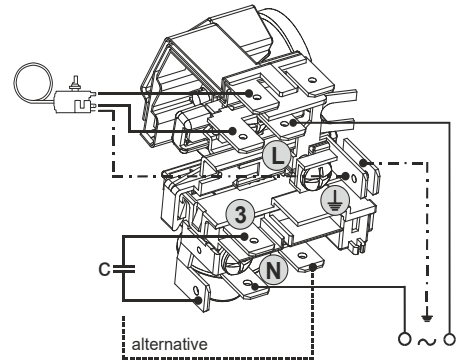
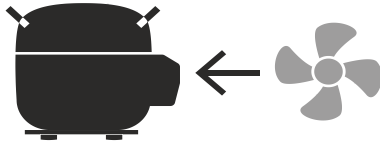

Operation pressure range

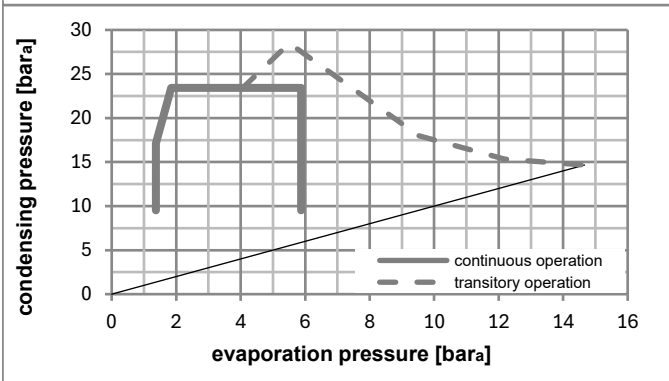
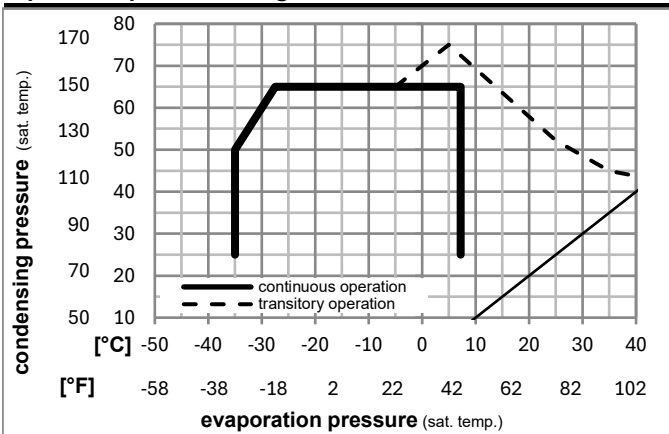

Components

| | | |
|------|------------------------------------|----------|
| a5 | current relay TY (1218/L6 - S7) | 117U7077 |
| c | start capacitor (80µF, 6.3mm) | 117U5003 |
| b, d | cover + clamp + screws(5VA) in bag | 103N1060 |

Alternative components

| | | |
|------|------------------------------------|----------|
| b, d | cover + clamp + screws(5VA-compl.) | 103N0600 |
|------|------------------------------------|----------|

Model

| | | | | | |
|-------------|------------------|----------------------|----------------|-------------|-----------------|
| Designation | KLF5.6CNT | 200-240V/50Hz | Conf. 1 | Sales code: | 106H2602 |
|-------------|------------------|----------------------|----------------|-------------|-----------------|

Optimization + standard conditions

R290, 220V/50Hz, CSIR, fan 3m/s, UL, CCC, CB under prep.

| | | Evaporating pressure (saturation temperature) | | | | Condensing pressure (saturation temperature) | | | Return gas temp. | | Liquid temp. | | Cooling capacity | | | COP | EER | Power consumption | | |
|------|------|---|-----|-----|------|--|---------|----------|------------------|----------|--------------|------|------------------|---------------------|------|----------------|-------------|-------------------|--|--|
| | | pe | pc | RGT | Tliq | [W] | [Btu/h] | [kcal/h] | [W/W] | [Btu/Wh] | [kcal/Wh] | P1 | I | Current consumption | | Ref. mass flow | | | | |
| [°C] | [°F] | | | | | | | | | | | [W] | [A] | [kg/h] | | | | | | |
| -23 | -10 | 54 | 130 | 32 | 90 | 32 | 90 | 270,9 | 925 | 233,2 | 1,54 | 5,26 | 1,33 | 175,9 | 1,22 | 2,74 | ASHRAE LBP | | | |
| -25 | -13 | 55 | 131 | 32 | 90 | 55 | 131 | 201,7 | 689 | 173,6 | 1,19 | 4,06 | 1,02 | 169,6 | 1,20 | 2,51 | cecomaf LBP | | | |
| -35 | -31 | 40 | 104 | 20 | 68 | 40 | 104 | 147,6 | 504 | 127,0 | 1,20 | 4,11 | 1,04 | 122,5 | 1,07 | 1,69 | EN12900 LBP | | | |
| -7 | 20 | 54 | 130 | 35 | 95 | 46 | 115 | 489,9 | 1673 | 421,6 | 2,06 | 7,03 | 1,77 | 238,1 | 1,43 | 5,59 | ASHRAE MBP | | | |
| -10 | 14 | 55 | 131 | 32 | 90 | 55 | 131 | 388,3 | 1326 | 334,2 | 1,71 | 5,83 | 1,47 | 227,4 | 1,39 | 4,91 | cecomaf MBP | | | |
| -10 | 14 | 45 | 113 | 20 | 68 | 45 | 113 | 430,8 | 1471 | 370,7 | 2,08 | 7,10 | 1,79 | 207,2 | 1,32 | 5,29 | EN12900 MBP | | | |

Performance tables

R290, 220V/50Hz, CSIR, fan 3m/s, UL, CCC, CB under prep.

| | pe | | Cooling capacity | | | COP | EER | P1 | I | m | |
|------------------|------|------|------------------|---------|----------|-------|----------|-----------|-------|------|--------|
| | [°C] | [°F] | [W] | [Btu/h] | [kcal/h] | [W/W] | [Btu/Wh] | [kcal/Wh] | [W] | [A] | [kg/h] |
| [°C / °F] | -35 | -31 | 146,9 | 502 | 126,4 | 1,13 | 3,87 | 0,97 | 129,7 | 1,09 | 1,65 |
| cond. pressure | -25 | -13 | 238,6 | 815 | 205,4 | 1,48 | 5,06 | 1,27 | 161,1 | 1,17 | 2,69 |
| pc= 45/113 | -15 | 5 | 367,1 | 1254 | 316,0 | 1,91 | 6,51 | 1,64 | 192,6 | 1,27 | 4,18 |
| return gas temp. | -10 | 14 | 448,4 | 1532 | 385,9 | 2,16 | 7,39 | 1,86 | 207,2 | 1,32 | 5,13 |
| RGT= 32/90 | -5 | 23 | 542,9 | 1854 | 467,2 | 2,46 | 8,42 | 2,12 | 220,3 | 1,36 | 6,25 |
| liquid temp | 0 | 32 | 651,7 | 2226 | 560,9 | 2,82 | 9,61 | 2,42 | 231,5 | 1,40 | 7,56 |
| Tliq= 45/113 | 7,2 | 45 | 836,4 | 2856 | 719,8 | 3,44 | 11,74 | 2,96 | 243,3 | 1,45 | 9,83 |
| [°C / °F] | -35 | -31 | 112,9 | 386 | 97,2 | 0,85 | 2,92 | 0,74 | 132,1 | 1,09 | 1,40 |
| cond. pressure | -25 | -13 | 201,7 | 689 | 173,6 | 1,19 | 4,06 | 1,02 | 169,6 | 1,20 | 2,51 |
| pc= 55/131 | -15 | 5 | 317,2 | 1083 | 273,0 | 1,52 | 5,19 | 1,31 | 208,6 | 1,32 | 3,99 |
| return gas temp | -10 | 14 | 388,3 | 1326 | 334,2 | 1,71 | 5,83 | 1,47 | 227,4 | 1,39 | 4,91 |
| RGT= 32/90 | -5 | 23 | 470,1 | 1605 | 404,5 | 1,92 | 6,55 | 1,65 | 245,1 | 1,45 | 5,99 |
| liquid temp | 0 | 32 | 563,7 | 1925 | 485,1 | 2,16 | 7,37 | 1,86 | 261,1 | 1,51 | 7,24 |
| Tliq= 55/131 | 7,2 | 45 | 722,2 | 2466 | 621,5 | 2,57 | 8,79 | 2,22 | 280,5 | 1,59 | 9,41 |

Model

| | | | | | |
|-------------|------------------|----------------------|----------------|-------------|-----------------|
| Designation | KLF5.6CNT | 200-240V/50Hz | Conf. 2 | Sales code: | 106H2602 |
|-------------|------------------|----------------------|----------------|-------------|-----------------|

Configuration

| | |
|------------------------|------------------|
| Motorconfiguration | RSCR |
| Power supply (nominal) | 200-240V/50Hz 1~ |
| Refrigerant | R290 |
| Application | LBP+MBP |
| Voltage range | 187-254V |
| Starting torque | LST |
| Approvals | UL |
| | CCC |
| | CB under prep. |

Electrical accessories / wiring diagram

RSCR

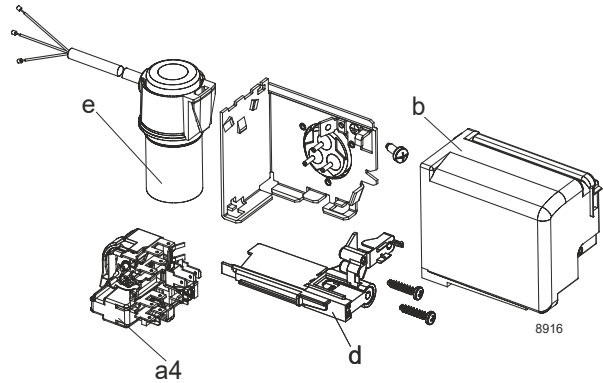

Ambient/ machine room temperatures minimum /maximum

Ambient temperature range: 10 - 43°C / 50 - 110°F

Machine room temperature range: 10 - 48°C / 50 - 119°F

Compressor cooling: fan 3m/s

Compressor with external protector. For max. operation envelope cooling on protector.

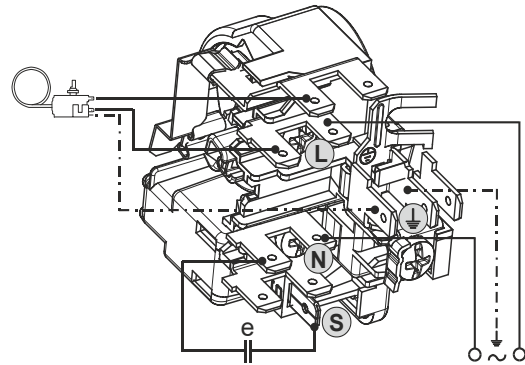
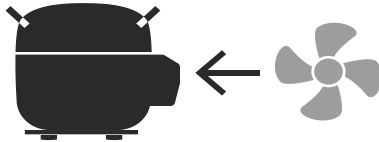

Operation pressure range

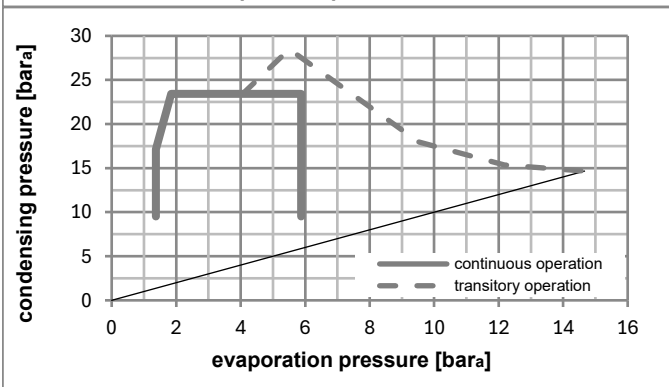
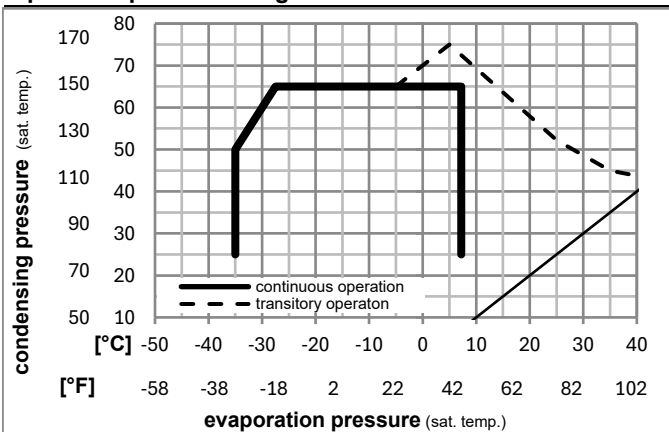

Components

| | | |
|------|------------------------------------|----------|
| a4 | DAS7 (PTC, 6.3mm, T1218/L6 - S7) | 103N0256 |
| e | run capacitor (5µF, 6,3mm) | 117-7155 |
| b, d | cover + clamp + screws(5VA) in bag | 103N1060 |

Alternative components

| | | |
|------|------------------------------------|----------|
| b, d | cover + clamp + screws(5VA-compl.) | 103N0600 |
|------|------------------------------------|----------|

Model

| | | | | | |
|-------------|------------------|----------------------|----------------|-------------|-----------------|
| Designation | KLF5.6CNT | 200-240V/50Hz | Conf. 2 | Sales code: | 106H2602 |
|-------------|------------------|----------------------|----------------|-------------|-----------------|

Optimization + standard conditions

R290, 220V/50Hz, RSCR, fan 3m/s, UL, CCC, CB under prep.

| | Evaporating pressure (saturation temperature) | | | | Cooling capacity | | | COP | EER | P1 | Power consumption | | ASHRAE LBP | |
|--|---|------|------|------|------------------|---------|----------|-------|----------|-----------|-------------------|------|------------|-------------|
| | pe | pc | RGT | Tliq | [W] | [Btu/h] | [kcal/h] | | | | I | m | | |
| | [°C] | [°C] | [°C] | [°C] | | | | [W/W] | [Btu/Wh] | [kcal/Wh] | [W] | [A] | [kg/h] | |
| | -23 | 54 | 32 | 32 | 276,0 | 943 | 237,6 | 1,61 | 5,49 | 1,38 | 171,7 | 0,93 | 2,80 | ASHRAE LBP |
| | [°F] | | | | | | | | | | | | | |
| | -10 | 130 | 90 | 90 | | | | | | | | | | |
| | -25 | 55 | 32 | 55 | 205,5 | 702 | 176,8 | 1,24 | 4,23 | 1,07 | 165,7 | 0,91 | 2,56 | cecomaf LBP |
| | [°F] | | | | | | | | | | | | | |
| | -13 | 131 | 90 | 131 | | | | | | | | | | |
| | -35 | 40 | 20 | 40 | 150,2 | 513 | 129,3 | 1,24 | 4,23 | 1,06 | 121,4 | 0,75 | 1,72 | EN12900 LBP |
| | [°F] | | | | | | | | | | | | | |
| | -31 | 104 | 68 | 104 | | | | | | | | | | |
| | -7 | 54 | 35 | 46 | 499,6 | 1706 | 430,0 | 2,16 | 7,37 | 1,86 | 231,6 | 1,18 | 5,70 | ASHRAE MBP |
| | [°F] | | | | | | | | | | | | | |
| | 20 | 130 | 95 | 115 | | | | | | | | | | |
| | -10 | 55 | 32 | 55 | 396,0 | 1352 | 340,8 | 1,79 | 6,11 | 1,54 | 221,3 | 1,14 | 5,01 | cecomaf MBP |
| | [°F] | | | | | | | | | | | | | |
| | 14 | 131 | 90 | 131 | | | | | | | | | | |
| | -10 | 45 | 20 | 45 | 439,1 | 1500 | 377,9 | 2,17 | 7,43 | 1,87 | 202,0 | 1,05 | 5,39 | EN12900 MBP |
| | [°F] | | | | | | | | | | | | | |
| | 14 | 113 | 68 | 113 | | | | | | | | | | |

Performance tables

R290, 220V/50Hz, RSCR, fan 3m/s, UL, CCC, CB under prep.

| | pe | | Cooling capacity | | | COP | EER | P1 | I | m | |
|------------------|------|------|------------------|---------|----------|------|-------|------|-------|------|-------|
| | [°C] | [°F] | [W] | [Btu/h] | [kcal/h] | | | | | | |
| [°C / °F] | -35 | -31 | 149,5 | 511 | 128,7 | 1,17 | 3,98 | 1,00 | 128,2 | 0,77 | 1,68 |
| cond. pressure | -25 | -13 | 243,1 | 830 | 209,2 | 1,54 | 5,27 | 1,33 | 157,6 | 0,87 | 2,74 |
| pc= 45/113 | -15 | 5 | 374,2 | 1278 | 322,0 | 1,99 | 6,80 | 1,71 | 187,8 | 0,99 | 4,26 |
| return gas temp. | -10 | 14 | 457,1 | 1561 | 393,4 | 2,26 | 7,73 | 1,95 | 202,0 | 1,05 | 5,23 |
| RGT= 32/90 | -5 | 23 | 553,5 | 1890 | 476,3 | 2,58 | 8,81 | 2,22 | 214,7 | 1,11 | 6,37 |
| liquid temp | 0 | 32 | 664,6 | 2270 | 572,0 | 2,95 | 10,07 | 2,54 | 225,4 | 1,16 | 7,71 |
| Tliq= 45/113 | 7,2 | 45 | 853,2 | 2914 | 734,3 | 3,61 | 12,33 | 3,11 | 236,4 | 1,20 | 10,02 |
| [°C / °F] | -35 | -31 | 115,0 | 393 | 98,9 | 0,88 | 3,01 | 0,76 | 130,2 | 0,78 | 1,42 |
| cond. pressure | -25 | -13 | 205,5 | 702 | 176,8 | 1,24 | 4,23 | 1,07 | 165,7 | 0,91 | 2,56 |
| pc= 55/131 | -15 | 5 | 323,4 | 1104 | 278,3 | 1,59 | 5,44 | 1,37 | 203,2 | 1,06 | 4,07 |
| return gas temp | -10 | 14 | 396,0 | 1352 | 340,8 | 1,79 | 6,11 | 1,54 | 221,3 | 1,14 | 5,01 |
| RGT= 32/90 | -5 | 23 | 479,5 | 1638 | 412,7 | 2,01 | 6,87 | 1,73 | 238,3 | 1,21 | 6,11 |
| liquid temp | 0 | 32 | 575,2 | 1964 | 495,0 | 2,27 | 7,75 | 1,95 | 253,6 | 1,28 | 7,39 |
| Tliq= 55/131 | 7,2 | 45 | 737,2 | 2518 | 634,5 | 2,71 | 9,27 | 2,34 | 271,6 | 1,35 | 9,60 |

Model

Designation **KLF5.6CNT** **208-230V/60Hz** Conf. 3 Sales code: **106H2602**

Configuration

Motorconfiguration CSIR
 Power supply (nominal) 208-230V/60Hz 1~
 Refrigerant R290
 Application LBP+MBP
 Voltage range 198-253V
 Starting torque HST
 Approvals UL
 CCC
 CB under prep.

Electrical accessories / wiring diagram

CSIR

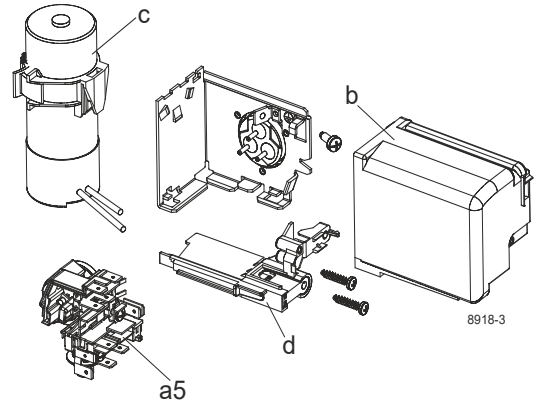

Ambient/ machine room temperatures minimum /maximum

Ambient temperature range: 10 - 43°C / 50 - 110°F
 Machine room temperature range: 10 - 48°C / 50 - 119°F

Compressor cooling: fan 3m/s

Compressor with external protector. For max. operation envelope cooling on protector.

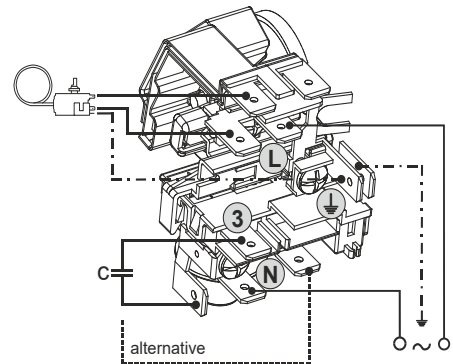
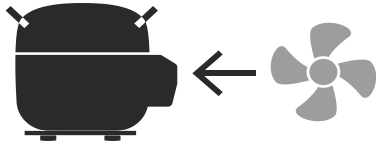

Operation pressure range

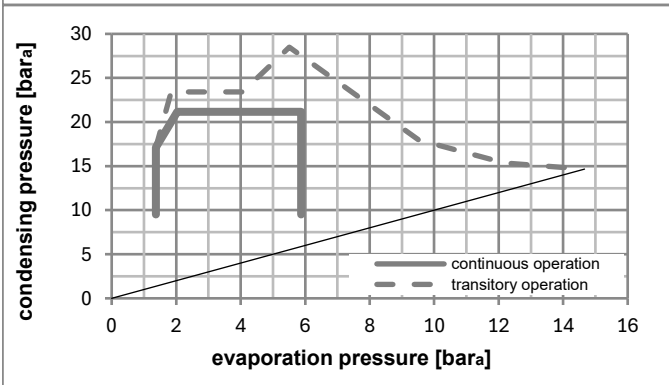
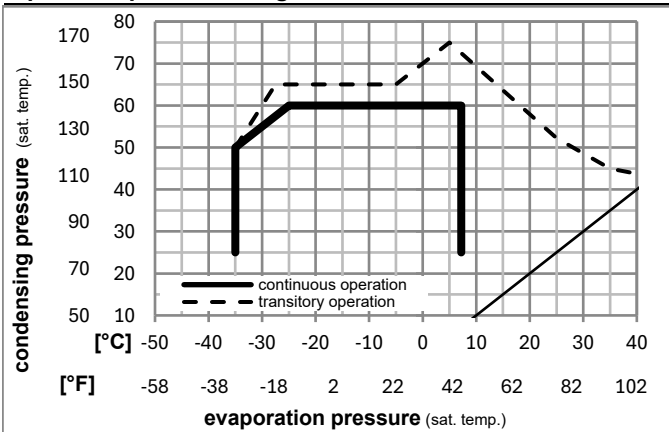

Components

| | | |
|------|------------------------------------|----------|
| a5 | current relay TY (1218/L6 - S7) | 117U7077 |
| c | start capacitor (80µF, 6.3mm) | 117U5003 |
| b, d | cover + clamp + screws(5VA) in bag | 103N1060 |

Alternative components

| | | |
|------|------------------------------------|----------|
| b, d | cover + clamp + screws(5VA-compl.) | 103N0600 |
|------|------------------------------------|----------|

Model

| | | | | | |
|-------------|------------------|----------------------|----------------|-------------|-----------------|
| Designation | KLF5.6CNT | 208-230V/60Hz | Conf. 3 | Sales code: | 106H2602 |
|-------------|------------------|----------------------|----------------|-------------|-----------------|

Optimization + standard conditions

R290, 230V/60Hz, CSIR, fan 3m/s, UL, CCC, CB under prep.

| | | Evaporating pressure (saturation temperature) | | | | Cooling capacity | | | COP | EER | Power consumption | | | | |
|------|------|---|------|------|-------|------------------|---------|----------|-------|----------|---------------------|------|------|--------------------|--|
| | | Condensing pressure (saturation temperature) | | | | Return gas temp. | | | | | Current consumption | | | | |
| | | Liquid temp. | | | | Cooling capacity | | | | | Ref. mass flow | | | | |
| | | pe | pc | RGT | Tliq | [W] | [Btu/h] | [kcal/h] | [W/W] | [Btu/Wh] | [kcal/Wh] | P1 | I | m | |
| [°C] | [°F] | [°C] | [°F] | [°C] | [°C] | | | | | | | [W] | [A] | [kg/h] | |
| [°C] | -23 | 54 | 32 | 32 | 331,7 | 1133 | 285,5 | 1,58 | 5,39 | 1,36 | 210,2 | 1,34 | 3,36 | ASHRAE LBP | |
| [°F] | -10 | 130 | 90 | 90 | | | | | | | | | | | |
| [°C] | -25 | 55 | 32 | 55 | 248,5 | 849 | 213,9 | 1,23 | 4,21 | 1,06 | 201,8 | 1,32 | 3,09 | cecomaf LBP | |
| [°F] | -13 | 131 | 90 | 131 | | | | | | | | | | | |
| [°C] | -35 | 40 | 20 | 40 | 188,7 | 645 | 162,4 | 1,21 | 4,13 | 1,04 | 156,2 | 1,19 | 2,16 | EN12900 LBP | |
| [°F] | -31 | 104 | 68 | 104 | | | | | | | | | | | |
| [°C] | -7 | 54 | 35 | 46 | 604,1 | 2063 | 519,9 | 2,07 | 7,06 | 1,78 | 292,4 | 1,62 | 6,89 | ASHRAE MBP | |
| [°F] | 20 | 130 | 95 | 115 | | | | | | | | | | | |
| [°C] | -10 | 55 | 32 | 55 | 478,0 | 1632 | 411,3 | 1,72 | 5,87 | 1,48 | 278,0 | 1,57 | 6,05 | cecomaf MBP | |
| [°F] | 14 | 131 | 90 | 131 | | | | | | | | | | | |
| [°C] | -10 | 45 | 20 | 45 | 538,2 | 1838 | 463,2 | 2,08 | 7,11 | 1,79 | 258,5 | 1,50 | 6,61 | EN12900 MBP | |
| [°F] | 14 | 113 | 68 | 113 | | | | | | | | | | | |

Performance tables

R290, 230V/60Hz, CSIR, fan 3m/s, UL, CCC, CB under prep.

| | pe | | Cooling capacity | | | COP | EER | P1 | I | m | |
|------------------|------|------|------------------|---------|----------|-------|----------|-----------|-------|------|--------|
| | [°C] | [°F] | [W] | [Btu/h] | [kcal/h] | [W/W] | [Btu/Wh] | [kcal/Wh] | [W] | [A] | [kg/h] |
| [°C / °F] | -35 | -31 | 180,4 | 616 | 155,3 | 1,14 | 3,90 | 0,98 | 157,8 | 1,20 | 2,02 |
| cond. pressure | -25 | -13 | 295,4 | 1009 | 254,3 | 1,49 | 5,09 | 1,28 | 198,3 | 1,31 | 3,33 |
| pc= 45/113 | -15 | 5 | 459,3 | 1569 | 395,3 | 1,92 | 6,55 | 1,65 | 239,6 | 1,44 | 5,23 |
| return gas temp. | -10 | 14 | 560,3 | 1914 | 482,2 | 2,17 | 7,40 | 1,87 | 258,5 | 1,50 | 6,41 |
| RGT= 32/90 | -5 | 23 | 674,4 | 2303 | 580,4 | 2,45 | 8,37 | 2,11 | 275,1 | 1,56 | 7,76 |
| liquid temp | 0 | 32 | 801,9 | 2739 | 690,1 | 2,78 | 9,49 | 2,39 | 288,6 | 1,60 | 9,30 |
| Tliq= 45/113 | 7,2 | 45 | 1009,6 | 3448 | 868,9 | 3,36 | 11,46 | 2,89 | 300,8 | 1,65 | 11,86 |
| [°C / °F] | -35 | -31 | 156,1 | 533 | 134,3 | 1,02 | 3,47 | 0,87 | 153,6 | 1,19 | 1,93 |
| cond. pressure | -25 | -13 | 248,5 | 849 | 213,9 | 1,23 | 4,21 | 1,06 | 201,8 | 1,32 | 3,09 |
| pc= 55/131 | -15 | 5 | 389,0 | 1328 | 334,8 | 1,54 | 5,25 | 1,32 | 253,2 | 1,48 | 4,89 |
| return gas temp | -10 | 14 | 478,0 | 1632 | 411,3 | 1,72 | 5,87 | 1,48 | 278,0 | 1,57 | 6,05 |
| RGT= 32/90 | -5 | 23 | 579,8 | 1980 | 499,0 | 1,93 | 6,58 | 1,66 | 301,2 | 1,65 | 7,39 |
| liquid temp | 0 | 32 | 694,9 | 2373 | 598,0 | 2,16 | 7,37 | 1,86 | 321,8 | 1,73 | 8,93 |
| Tliq= 55/131 | 7,2 | 45 | 884,3 | 3020 | 761,1 | 2,56 | 8,74 | 2,20 | 345,4 | 1,82 | 11,52 |

Model

| | | | | | |
|-------------|------------------|----------------------|----------------|-------------|-----------------|
| Designation | KLF5.6CNT | 208-230V/60Hz | Conf. 4 | Sales code: | 106H2602 |
|-------------|------------------|----------------------|----------------|-------------|-----------------|

Configuration

| | |
|------------------------|-----------------------------|
| Motorconfiguration | RSCR |
| Power supply (nominal) | 208-230V/60Hz 1~ |
| Refrigerant | R290 |
| Application | LBP+MBP |
| Voltage range | 198-253V |
| Starting torque | LST |
| Approvals | UL CCC CB under prep. |

Electrical accessories / wiring diagram

RSCR

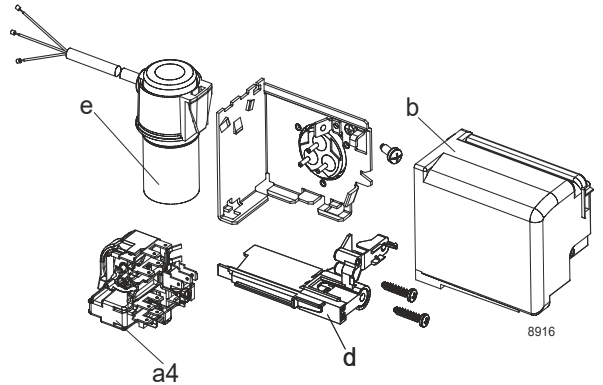

Ambient/ machine room temperatures minimum /maximum

| | |
|---------------------------------|------------------------|
| Ambient temperature range: | 10 - 43°C / 50 - 110°F |
| Machine room temperature range: | 10 - 48°C / 50 - 119°F |

Compressor cooling: fan 3m/s

Compressor with external protector. For max. operation envelope cooling on protector.

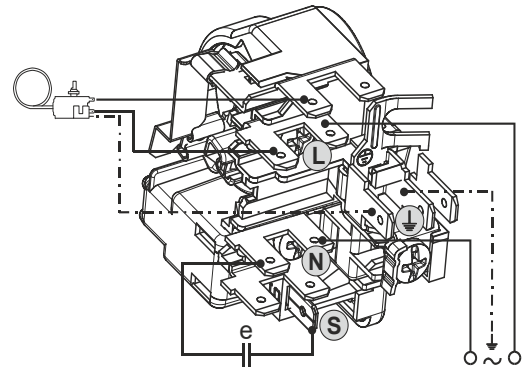
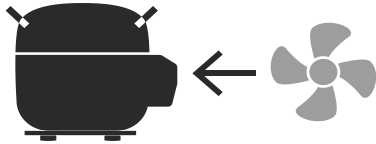

Operation pressure range

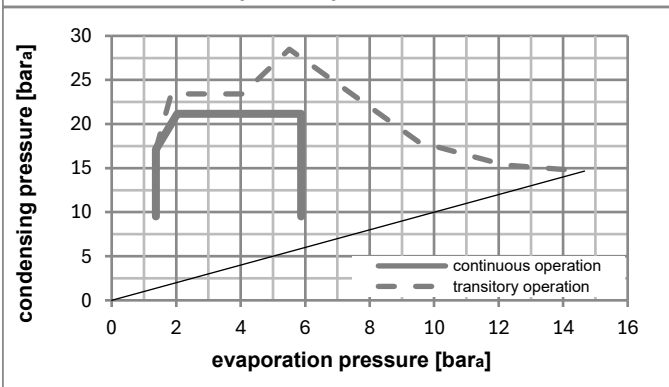
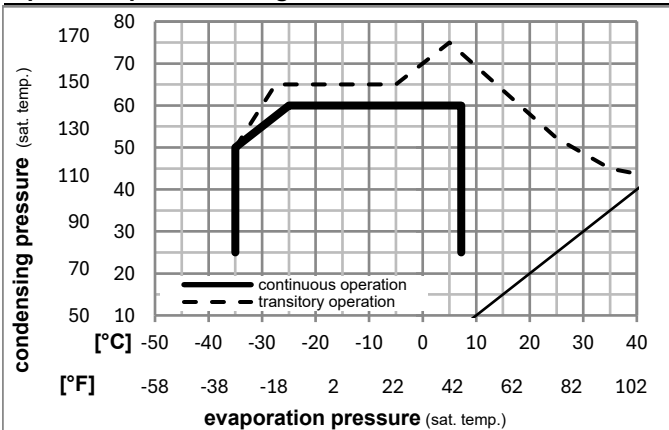

Components

| | | |
|------|------------------------------------|----------|
| a4 | DAS7 (PTC, 6.3mm, T1218/L6 - S7) | 103N0256 |
| e | run capacitor (5µF, 6,3mm) | 117-7155 |
| b, d | cover + clamp + screws(5VA) in bag | 103N1060 |

Alternative components

| | | |
|------|------------------------------------|----------|
| b, d | cover + clamp + screws(5VA-compl.) | 103N0600 |
|------|------------------------------------|----------|

Model

| | | | | | |
|-------------|------------------|----------------------|----------------|-------------|-----------------|
| Designation | KLF5.6CNT | 208-230V/60Hz | Conf. 4 | Sales code: | 106H2602 |
|-------------|------------------|----------------------|----------------|-------------|-----------------|

Optimization + standard conditions

R290, 230V/60Hz, RSCR, fan 3m/s, UL, CCC, CB under prep.

| | | Evaporating pressure (saturation temperature) | | | | Cooling capacity | | | COP | EER | Power consumption | | | | |
|------|------|---|------|------|------|------------------|---------|----------|-------|----------|---------------------|-------|------|--------|-------------|
| | | Condensing pressure (saturation temperature) | | | | Return gas temp. | | | | | Current consumption | | | | |
| | | Liquid temp. | | | | Cooling capacity | | | | | Ref. mass flow | | | | |
| | | pe | pc | RGT | Tliq | [W] | [Btu/h] | [kcal/h] | [W/W] | [Btu/Wh] | [kcal/Wh] | P1 | I | m | |
| [°C] | [°F] | [°C] | [°F] | [°C] | [°C] | | | | | | | [W] | [A] | [kg/h] | |
| -23 | -10 | 54 | 130 | 32 | 32 | 338,4 | 1156 | 291,2 | 1,68 | 5,73 | 1,44 | 201,7 | 1,04 | 3,43 | ASHRAE LBP |
| -25 | -13 | 55 | 131 | 32 | 55 | 253,6 | 866 | 218,2 | 1,31 | 4,47 | 1,13 | 193,7 | 1,01 | 3,16 | cecomaf LBP |
| -35 | -31 | 40 | 104 | 20 | 40 | 192,5 | 658 | 165,7 | 1,28 | 4,37 | 1,10 | 150,4 | 0,83 | 2,20 | EN12900 LBP |
| -7 | 20 | 54 | 130 | 35 | 46 | 616,4 | 2105 | 530,5 | 2,20 | 7,50 | 1,89 | 280,6 | 1,38 | 7,03 | ASHRAE MBP |
| -10 | 14 | 55 | 131 | 32 | 55 | 487,7 | 1665 | 419,7 | 1,83 | 6,24 | 1,57 | 266,7 | 1,32 | 6,17 | cecomaf MBP |
| -10 | 14 | 45 | 113 | 20 | 45 | 549,1 | 1875 | 472,6 | 2,21 | 7,55 | 1,90 | 248,3 | 1,24 | 6,74 | EN12900 MBP |

Performance tables

R290, 230V/60Hz, RSCR, fan 3m/s, UL, CCC, CB under prep.

| | pe | | Cooling capacity | | | COP | EER | P1 | I | m | |
|------------------|------|------|------------------|---------|----------|-------|----------|-----------|-------|------|--------|
| | [°C] | [°F] | [W] | [Btu/h] | [kcal/h] | [W/W] | [Btu/Wh] | [kcal/Wh] | [W] | [A] | [kg/h] |
| [°C / °F] | -35 | -31 | 184,1 | 629 | 158,4 | 1,21 | 4,14 | 1,04 | 151,8 | 0,84 | 2,06 |
| cond. pressure | -25 | -13 | 301,4 | 1029 | 259,4 | 1,58 | 5,40 | 1,36 | 190,5 | 0,99 | 3,40 |
| pc= 45/113 | -15 | 5 | 468,6 | 1600 | 403,3 | 2,04 | 6,95 | 1,75 | 230,2 | 1,16 | 5,33 |
| return gas temp. | -10 | 14 | 571,6 | 1952 | 492,0 | 2,30 | 7,86 | 1,98 | 248,3 | 1,24 | 6,54 |
| RGT= 32/90 | -5 | 23 | 688,1 | 2350 | 592,1 | 2,60 | 8,89 | 2,24 | 264,2 | 1,31 | 7,92 |
| liquid temp | 0 | 32 | 818,1 | 2794 | 704,1 | 2,95 | 10,08 | 2,54 | 277,1 | 1,36 | 9,49 |
| Tliq= 45/113 | 7,2 | 45 | 1030,1 | 3518 | 886,5 | 3,57 | 12,18 | 3,07 | 288,9 | 1,42 | 12,10 |
| [°C / °F] | -35 | -31 | 159,2 | 544 | 137,0 | 1,08 | 3,68 | 0,93 | 147,7 | 0,82 | 1,97 |
| cond. pressure | -25 | -13 | 253,6 | 866 | 218,2 | 1,31 | 4,47 | 1,13 | 193,7 | 1,01 | 3,16 |
| pc= 55/131 | -15 | 5 | 396,9 | 1355 | 341,6 | 1,63 | 5,58 | 1,41 | 242,9 | 1,21 | 4,99 |
| return gas temp | -10 | 14 | 487,7 | 1665 | 419,7 | 1,83 | 6,24 | 1,57 | 266,7 | 1,32 | 6,17 |
| RGT= 32/90 | -5 | 23 | 591,6 | 2021 | 509,2 | 2,05 | 6,99 | 1,76 | 288,9 | 1,42 | 7,54 |
| liquid temp | 0 | 32 | 709,0 | 2421 | 610,2 | 2,30 | 7,84 | 1,98 | 308,7 | 1,50 | 9,11 |
| Tliq= 55/131 | 7,2 | 45 | 902,4 | 3082 | 776,6 | 2,72 | 9,30 | 2,34 | 331,4 | 1,61 | 11,76 |