

## Model

Designation	<b>KLF6.6CND</b>	<b>220-240V/50Hz 1~</b>	Sales code:	<b>106H2700</b>
-------------	------------------	-------------------------	-------------	-----------------

## Compressor design

Oil type	Polyolester	Refrigerant(s)	<b>R290</b>
Oil viscosity	9,7cST	Displacement	6,6cm <sup>3</sup> / 0,4cu.in
Oil quantity	170cm <sup>3</sup> / 5,7fl.oz	Compressors on pallet	100
Refr. charge - tech. limit	200g / 7,1oz		
Free gas volume comp.	1583cm <sup>3</sup> / 53,5fl.oz		
Weight	9,5kg / 20,9lbs		
Motor protection	external		
Winding resistance main	8,4Ω (at 25°C)		
Winding resistance aux	11,9Ω (at 25°C)		
Max. winding temp.	125°C / 257°F		
Max. discharge temp.	130°C / 266°F		



## General - Configurations with KLF6.6CND

	<b>Conf. 1</b>	<b>Conf. 2</b>
Motorconfiguration	CSIR	RSCR
Power supply (nominal)	220-240V/50Hz	220-240V/50Hz
Number of phases	1	1
Voltage range	198-254V	198-254V
Approvals	VDE, CCC	VDE, CCC
Starting torque	HST	LST
Note	- / -	

## Applications with KLF6.6CND

	<b>Conf. 1</b>	<b>Conf. 2</b>
Refrigerant	R290	R290
Application	LBP+MBP	LBP+MBP
System cooling	fan 3m/s	fan 3m/s
Hot gas defrost	OK	OK
Long interval pull down	OK	OK

## Electrical data - Configurations with KLF6.6CND

	<b>Conf. 1</b>	<b>Conf. 2</b>
Starting device type	relay	PTC
Run capacitor	-/-	5μF
Start capacitor	80μF	-/-
LRA (locked rotor amps / 4s/ U(N))	13,2A	13,2A
RLA (rated load amps / 1s/ U(N))	2,1A	2,1A
Cut in current (U(N))	12,3A	18,1A

## Model

Designation	<b>KLF6.6CND</b>	220-240V/50Hz 1~	Sales code:	<b>106H2700</b>
-------------	------------------	------------------	-------------	-----------------

## Compressor dimensions

<b>Housing</b>	A Height	182mm / 7,17in
	B Height	175mm / 6,89in
	C Length shell	198mm / 7,8in
	D Length w. cover	238mm / 9,37in
	E Width	160mm / 6,3in

<b>Connectors</b>		<b>Suction</b>	<b>Discharge</b>	<b>Process</b>
		<b>X</b>	<b>Y</b>	<b>Z</b>
Diameter	[mm]	øi 8,11-8,29	øi 6,11-6,29	øi 6,11-6,29
	(i:inside, o:outside) [in]	øi 0,32-0,33	øi 0,24-0,25	øi 0,24-0,25
Material		copper	copper	copper
Horizontal angle	±2°	35°	13°	0°
Vertical angle	±2°	30°	40°	145°
Position l/h/w	[mm]	120/72/57	112/106/81	-97/94/72
	[in]	4,7/2,8/2,2	4,4/4,2/3,2	-3,8/3,7/2,8
Straight tube l.	[mm]	14	14	14
	[in]	0,5	0,5	0,5

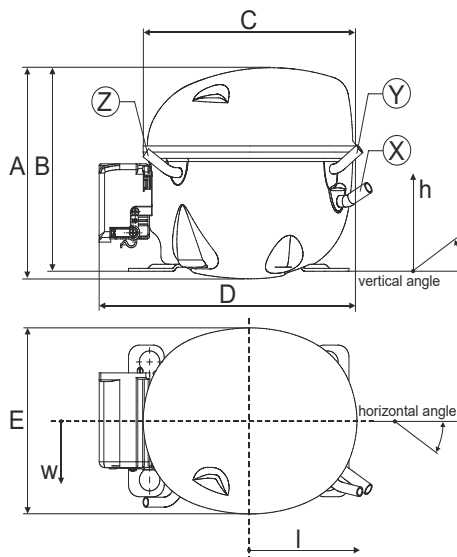

## Compressor fixation

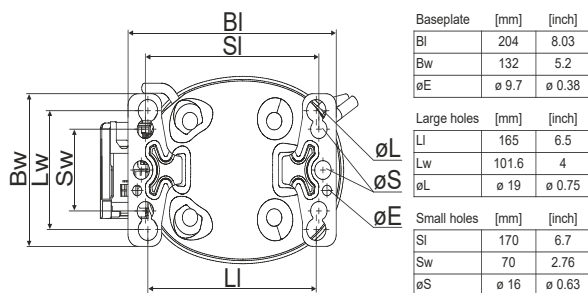

### Bolt joint

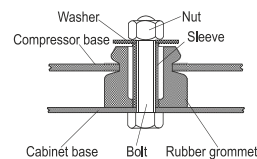

### Snap-on

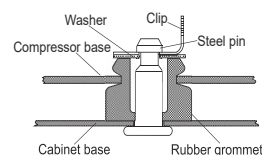

<b>Mounting accessories</b>	one comp.	multi pack
Bolt joint   M6   ø16mm	118-1917	118-1918
Bolt joint   ø1/4"   ø16mm	118-1946	
Bolt joint   ø1/4"   ø19mm	118-1949	
Snap-on   ø7,3   ø16mm	118-1947	118-1919

## Application notes

Provision for PE Grounding is located at the PE Stamp on the compressor

## Model

Designation	<b>KLF6.6CND</b>	<b>220-240V/50Hz</b>	Conf. 1	Sales code:	<b>106H2700</b>
-------------	------------------	----------------------	---------	-------------	-----------------

## Configuration

Motorconfiguration	CSIR
Power supply (nominal)	220-240V/50Hz 1~
Refrigerant	R290
Application	LBP+MBP
Voltage range	198-254V
Starting torque	HST
Approvals	VDE CCC

## Electrical accessories / wiring diagram

CSIR

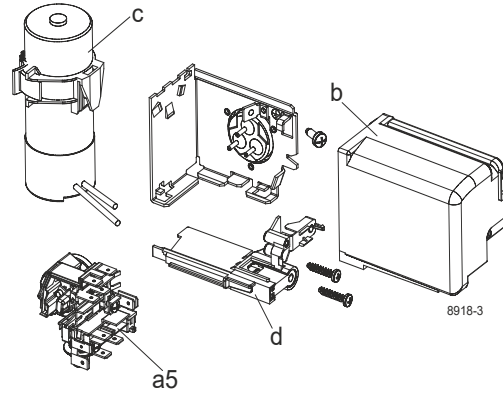

## Ambient/ machine room temperatures minimum /maximum

Ambient temperature range:	10 - 43°C / 50 - 110°F
Machine room temperature range:	10 - 48°C / 50 - 119°F
Compressor cooling:	fan 3m/s

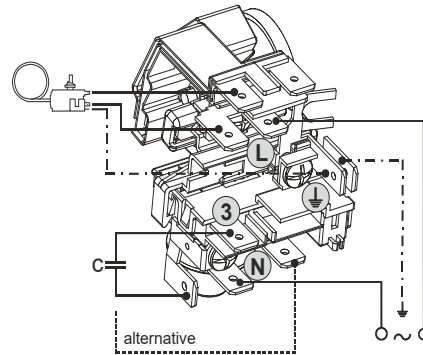

## Operation pressure range

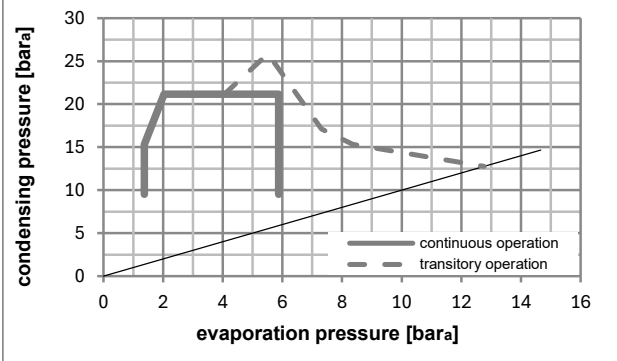
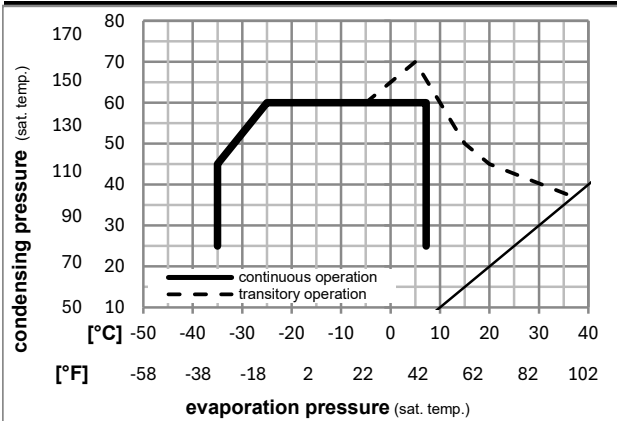

## Components

a5	current relay (T0377/L6-S1)	117U7071
c	start capacitor (80μF, 6.3mm)	117U5001
b, d	cover + clamp + screws(5VA) in bag	103N1060

## Alternative components

b, d	100x cover + clamp + screws(5VA)	103N2060
b, d	cover + clamp + screws(5VA-compl.)	103N0600

### Model

Designation **KLF6.6CND** **220-240V/50Hz** Conf. 1 Sales code: **106H2700**

### Optimization + standard conditions

R290, 220V/50Hz, CSIR, fan 3m/s, VDE, CCC

Evaporating pressure (saturation temperature)				Condensing pressure (saturation temperature)			Power consumption				Ref. mass flow ṁ			
Return gas temp.		Liquid temp.		Cooling capacity		COP	EER	P1	I					
pe	pc	RGT	Tliq	[W]	[Btu/h]	[kcal/h]	[W/W]	[Btu/Wh]	[kcal/Wh]	[W]	[A]	[kg/h]		
[°C]	-23	54	32	32	336,8	1150	289,9	1,51	5,15	1,30	223,4	1,59	3,41	ASHRAE LBP
[°F]	-10	130	90	90										
[°C]	-25	55	32	55	251,5	859	216,5	1,17	3,98	1,00	215,7	1,57	3,13	cecomaf LBP
[°F]	-13	131	90	131										
[°C]	-35	40	20	40	188,2	643	161,9	1,20	4,11	1,04	156,3	1,42	2,15	EN12900 LBP
[°F]	-31	104	68	104										
[°C]	-7	54	35	46	595,8	2035	512,8	2,01	6,88	1,73	296,0	1,82	6,80	ASHRAE MBP
[°F]	20	130	95	115										
[°C]	-10	55	32	55	475,1	1622	408,9	1,67	5,70	1,44	284,6	1,78	6,01	cecomaf MBP
[°F]	14	131	90	131										
[°C]	-10	45	20	45	525,2	1794	452,0	2,04	6,98	1,76	257,0	1,69	6,45	EN12900 MBP
[°F]	14	113	68	113										

### Performance tables

R290, 220V/50Hz, CSIR, fan 3m/s, VDE, CCC

	pe		Cooling capacity			COP	EER	P1	I	m	
	[°C]	[°F]	[W]	[Btu/h]	[kcal/h]	[W/W]	[Btu/Wh]	[kcal/Wh]	[W]	[A]	[kg/h]
[°C / °F]	-35	-31	178,1	608	153,2	1,12	3,82	0,96	159,2	1,43	2,00
cond. pressure	-25	-13	294,9	1007	253,8	1,46	4,97	1,25	202,7	1,53	3,33
pc= 45/113	-15	5	450,6	1539	387,8	1,87	6,40	1,61	240,5	1,64	5,13
return gas temp.	-10	14	546,8	1867	470,6	2,13	7,27	1,83	257,0	1,69	6,26
RGT= 32/90	-5	23	657,2	2245	565,6	2,42	8,26	2,08	271,8	1,74	7,57
liquid temp	0	32	783,4	2675	674,2	2,75	9,40	2,37	284,7	1,78	9,09
Tliq= 45/113	7,2	45	995,8	3401	857,0	3,32	11,34	2,86	299,9	1,84	11,70
[°C / °F]	-35	-31	139,7	477	120,3	0,87	2,96	0,74	161,5	1,44	1,73
cond. pressure	-25	-13	251,5	859	216,5	1,17	3,98	1,00	215,7	1,57	3,13
pc= 55/131	-15	5	391,1	1336	336,6	1,48	5,07	1,28	263,4	1,71	4,92
return gas temp.	-10	14	475,1	1622	408,9	1,67	5,70	1,44	284,6	1,78	6,01
RGT= 32/90	-5	23	570,5	1948	491,0	1,88	6,41	1,62	303,8	1,85	7,27
liquid temp	0	32	679,0	2319	584,3	2,12	7,23	1,82	320,9	1,91	8,72
Tliq= 55/131	7,2	45	861,0	2940	741,0	2,52	8,60	2,17	341,8	1,99	11,22

## Model

Designation	<b>KLF6.6CND</b>	<b>220-240V/50Hz</b>	<b>Conf. 2</b>	Sales code:	<b>106H2700</b>
-------------	------------------	----------------------	----------------	-------------	-----------------

## Configuration

Motorconfiguration	RSCR
Power supply (nominal)	220-240V/50Hz 1~
Refrigerant	R290
Application	LBP+MBP
Voltage range	198-254V
Starting torque	LST
Approvals	VDE
	CCC

## Electrical accessories / wiring diagram

RSCR

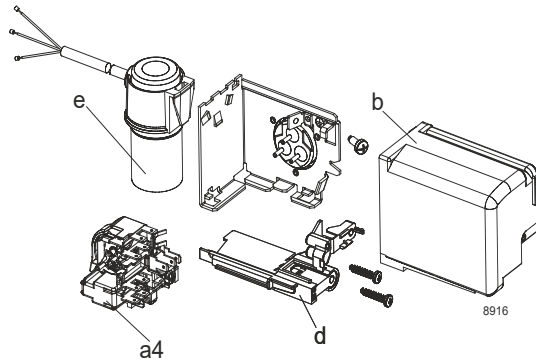

## Ambient/ machine room temperatures minimum /maximum

Ambient temperature range:	10 - 43°C / 50 - 110°F
Machine room temperature range:	10 - 48°C / 50 - 119°F
Compressor cooling:	fan 3m/s

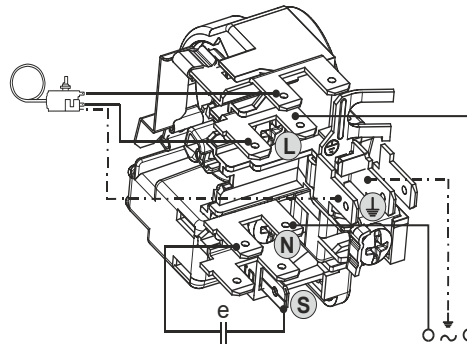

## Operation pressure range

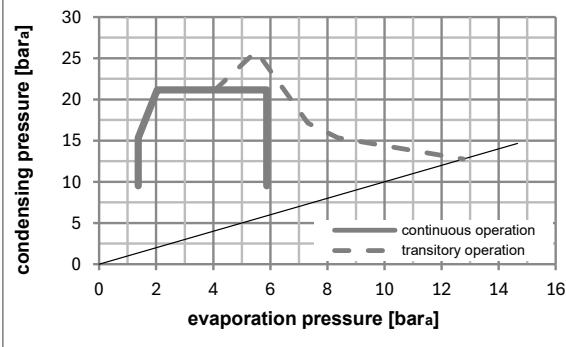
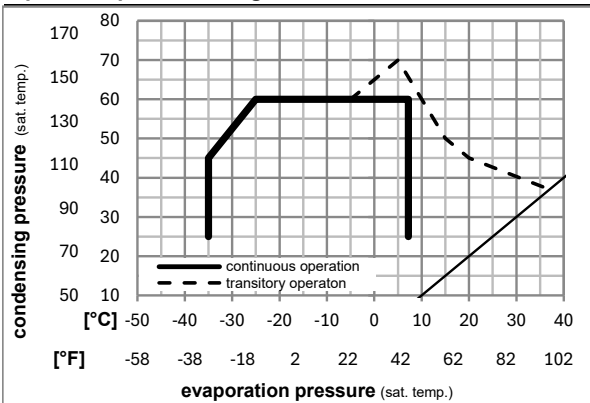

## Components

a4	DAS1 (PTC,6.3mm, T0377/L6 - S1)	103N0250
e	run capacitor (5μF, 6.3mm)	117-7191
b, d	cover + clamp + screws(5VA) in bag	103N1060

## Alternative components

a4	ZAS1 (PTC,4.8mm, T0377/L6 - S1)	103N0252
e	run capacitor (5μF, 4.8mm)	117-7190

b, d	100x cover + clamp + screws(5VA)	103N2060
b, d	cover + clamp + screws(5VA-compl.)	103N0600

## Model

Designation	<b>KLF6.6CND</b>	<b>220-240V/50Hz</b>	<b>Conf. 2</b>	Sales code:	<b>106H2700</b>
-------------	------------------	----------------------	----------------	-------------	-----------------

## Optimization + standard conditions

R290, 220V/50Hz, RSCR, fan 3m/s, VDE, CCC

		Evaporating pressure (saturation temperature)				Condensing pressure (saturation temperature)						Power consumption					
		Return gas temp.				Liquid temp.						Current consumption			Ref. mass flow		
		Cooling capacity				COP	EER	P1			I	m					
		pe	pc	RGT	Tliq	[W]	[Btu/h]	[kcal/h]	[W/W]	[Btu/Wh]	[kcal/Wh]	[W]	[A]	[kg/h]			
[°C]	[°F]	[°C]	[°F]	[°C]	[°F]												
-23	-10	54	130	32	90	32	90	337,5	1153	290,5	1,58	5,40	1,36	213,6	1,25	3,42	ASHRAE LBP
-25	-13	55	131	32	90	55	131	252,1	861	216,9	1,22	4,17	1,05	206,3	1,23	3,14	cecomaf LBP
-35	-31	40	104	20	68	40	104	188,4	643	162,1	1,25	4,28	1,08	150,3	1,05	2,15	EN12900 LBP
-7	20	54	130	35	95	46	115	597,8	2041	514,4	2,12	7,24	1,83	281,8	1,51	6,82	ASHRAE MBP
-10	14	55	131	32	90	55	131	476,5	1627	410,1	1,76	6,00	1,51	271,1	1,47	6,03	cecomaf MBP
-10	14	45	113	20	68	45	113	526,6	1799	453,2	2,15	7,34	1,85	245,2	1,37	6,47	EN12900 MBP

## Performance tables

R290, 220V/50Hz, RSCR, fan 3m/s, VDE, CCC

	pe		Cooling capacity			COP	EER	P1			I	m
	[°C]	[°F]	[W]	[Btu/h]	[kcal/h]	[W/W]	[Btu/Wh]	[kcal/Wh]	[W]	[A]	[kg/h]	
[°C / °F]	-35	-31	178,3	609	153,4	1,17	3,98	1,00	152,9	1,06	2,00	
cond. pressure	-25	-13	295,5	1009	254,3	1,52	5,20	1,31	194,1	1,18	3,33	
pc= 45/113	-15	5	451,7	1543	388,7	1,97	6,72	1,69	229,7	1,31	5,14	
return gas temp.	-10	14	548,3	1872	471,8	2,24	7,64	1,92	245,2	1,37	6,27	
RGT= 32/90	-5	23	659,1	2251	567,2	2,54	8,69	2,19	259,1	1,42	7,59	
liquid temp	0	32	785,8	2684	676,3	2,90	9,89	2,49	271,3	1,47	9,11	
Tliq= 45/113	7,2	45	999,1	3412	859,8	3,50	11,94	3,01	285,7	1,53	11,74	
[°C / °F]	-35	-31	139,9	478	120,4	0,90	3,08	0,78	155,0	1,07	1,73	
cond. pressure	-25	-13	252,1	861	216,9	1,22	4,17	1,05	206,3	1,23	3,14	
pc= 55/131	-15	5	392,2	1339	337,5	1,56	5,33	1,34	251,2	1,39	4,93	
return gas temp	-10	14	476,5	1627	410,1	1,76	6,00	1,51	271,1	1,47	6,03	
RGT= 32/90	-5	23	572,4	1955	492,6	1,98	6,76	1,70	289,2	1,54	7,29	
liquid temp	0	32	681,4	2327	586,4	2,23	7,62	1,92	305,3	1,61	8,75	
Tliq= 55/131	7,2	45	864,3	2952	743,8	2,66	9,08	2,29	325,1	1,69	11,26	