

## Model

Designation	<b>KLF6.6CND</b>	220-240V/50Hz 1~	Sales code:	<b>106H2710</b>
-------------	------------------	------------------	-------------	-----------------

## Compressor design

Oil type	Polyolester	Refrigerant(s)	<b>R290</b>
Oil viscosity	9,7cST	Displacement	6,6cm <sup>3</sup> / 0,4cu.in
Oil quantity	170cm <sup>3</sup> / 5,7fl.oz	Compressors on pallet	100
Refr. charge - tech. limit	200g / 7,1oz		
Free gas volume comp.	1583cm <sup>3</sup> / 53,5fl.oz		
Weight	9,5kg / 20,9lbs		
Motor protection	external		
Winding resistance main	8,4Ω (at 25°C)		
Winding resistance aux	11,9Ω (at 25°C)		
Max. winding temp.	125°C / 257°F		
Max. discharge temp.	130°C / 266°F		



## General - Configurations with KLF6.6CND

	<b>Conf. 1</b>
Motorconfiguration	CSIR
Power supply (nominal)	220-240V/50Hz
Number of phases	1
Voltage range	198-254V
Approvals	VDE, CCC
Starting torque	HST
Note	Electrical equipment is included and pre-assembled to compressor.

## Applications with KLF6.6CND

	<b>Conf. 1</b>
Refrigerant	R290
Application	LBP+MBP
System cooling	fan 3m/s
Hot gas defrost	OK
Long interval pull down	OK

## Electrical data - Configurations with KLF6.6CND

	<b>Conf. 1</b>
Starting device type	relay
Run capacitor	-/-
Start capacitor	80μF
LRA (locked rotor amps / 4s)	12,3A
RLA (rated load amps / 1s)	2,1A
Cut in current	12,3A

## Model

Designation

**KLF6.6CND**

220-240V/50Hz 1~

Sales code:

**106H2710**

## Compressor dimensions

Housing	A Height	182mm / 7,17in
	B Height	175mm / 6,89in
	C Length shell	198mm / 7,8in
	D Length w. cover	238mm / 9,37in
	E Width	160mm / 6,3in

Connectors		Suction	Discharge	Process
		X	Y	Z
Diameter	[mm]	øi 8,11-8,29	øi 6,11-6,29	øi 6,11-6,29
	(i:inside, o:outside) [in]	øi 0,32-0,33	øi 0,24-0,25	øi 0,24-0,25
Material		copper	copper	copper
Horizontal angle	±2°	35°	13°	0°
Vertical angle	±2°	30°	40°	145°
Position l/h/w	[mm]	120/72/57	112/106/81	-97/94/72
	[in]	4,7/2,8/2,2	4,4/4,2/3,2	-3,8/3,7/2,8
Straight tube l.	[mm]	14	14	14
	[in]	0,5	0,5	0,5

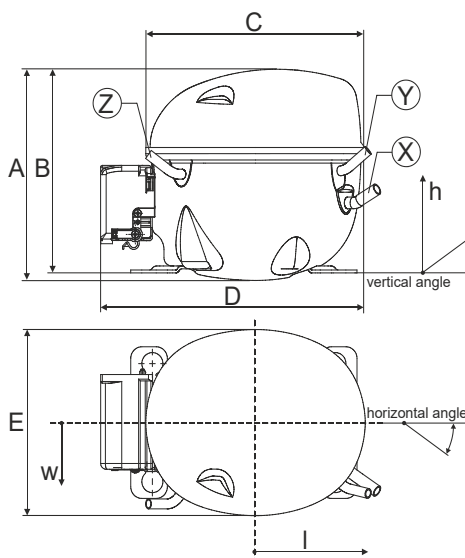

## Compressor fixation

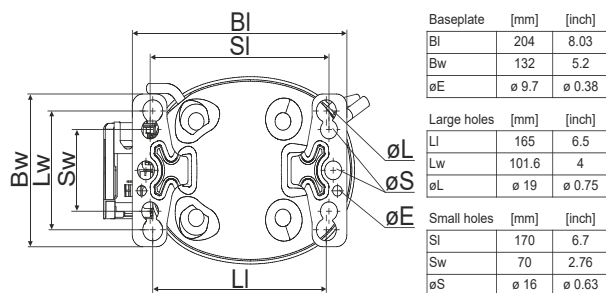

## Bolt joint

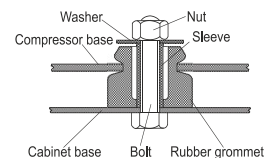

## Snap-on

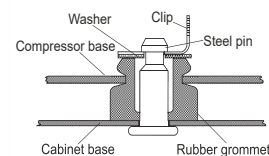

## Mounting accessories

Mounting accessories	one comp.	multi pack
Bolt joint   M6   ø16mm	118-1917	118-1918
Bolt joint   ø1/4"   ø16mm	118-1946	
Bolt joint   ø1/4"   ø19mm	118-1949	
Snap-on   ø7,3   ø16mm	118-1947	118-1919

## Application notes

Provision for PE Grounding is located at the PE Stamp on the compressor

## Model

Designation	<b>KLF6.6CND</b>	<b>220-240V/50Hz</b>	Conf. 1	Sales code:	<b>106H2710</b>
-------------	------------------	----------------------	---------	-------------	-----------------

## Configuration

Motorconfiguration	CSIR
Power supply (nominal)	220-240V/50Hz 1~
Refrigerant	R290
Application	LBP+MBP
Voltage range	198-254V
Starting torque	HST
Approvals	VDE
	CCC

## Electrical accessories / wiring diagram

CSIR

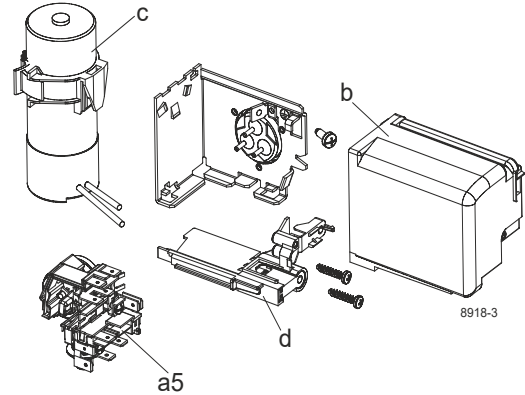

## Ambient/ machine room temperatures minimum /maximum

Ambient temperature range: 10 - 43°C / 50 - 110°F

Machine room temperature range: 10 - 48°C / 50 - 119°F

Compressor cooling: fan 3m/s

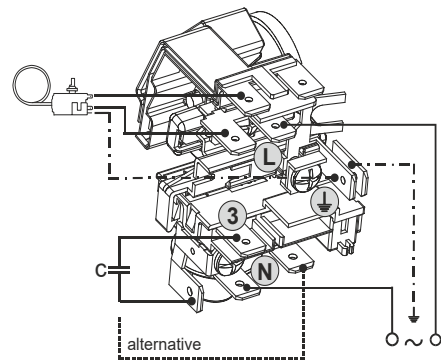

## Operation pressure range

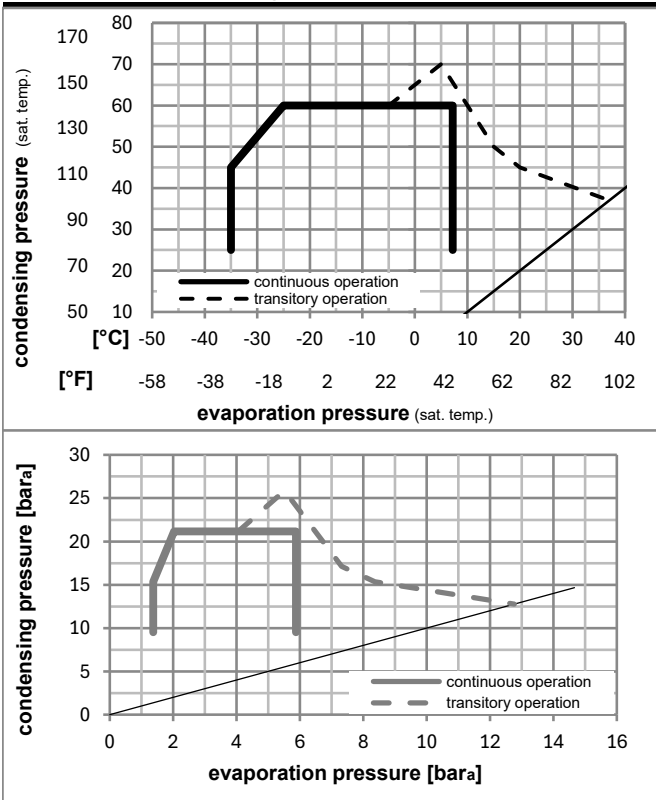

## Components (already pre-assembled)

a5	current relay (T0377/L6-S1)	117U7071
c	start capacitor (80µF, 6.3mm)	117U5001
b	cover terminal board	10636401
.	screw uni en iso 4757	10641201

## Alternative comp. (already pre-assembled)

.	cable clamp (screws not included)	16058100
.	screw - uni6954	10636000
.	screw - uni6954	10636200

## Model

Designation	<b>KLF6.6CND</b>	<b>220-240V/50Hz</b>	<b>Conf. 1</b>	Sales code:	<b>106H2710</b>
-------------	------------------	----------------------	----------------	-------------	-----------------

## Optimization + standard conditions

R290, 220V/50Hz, CSIR, fan 3m/s, VDE, CCC

	Evaporating pressure (saturation temperature)				Cooling capacity			COP	EER	P1	Power consumption		ASHRAE LBP	
	pe	pc	RGT	Tliq	[W]	[Btu/h]	[kcal/h]				I	m		
	[°C]	[°F]	[°C]	[°F]	[W]	[Btu/h]	[kcal/h]	[W/W]	[Btu/Wh]	[kcal/Wh]	[W]	[A]	[kg/h]	
	-23	54	32	32	336,8	1150	289,9	1,51	5,15	1,30	223,4	1,59	3,41	ASHRAE LBP
	-10	130	90	90										
	-25	55	32	55	251,5	859	216,5	1,17	3,98	1,00	215,7	1,57	3,13	cecomaf LBP
	-13	131	90	131										
	-35	40	20	40	188,2	643	161,9	1,20	4,11	1,04	156,3	1,42	2,15	EN12900 LBP
	-31	104	68	104										
	-7	54	35	46	595,8	2035	512,8	2,01	6,88	1,73	296,0	1,82	6,80	ASHRAE MBP
	20	130	95	115										
	-10	55	32	55	475,1	1622	408,9	1,67	5,70	1,44	284,6	1,78	6,01	cecomaf MBP
	14	131	90	131										
	-10	45	20	45	525,2	1794	452,0	2,04	6,98	1,76	257,0	1,69	6,45	EN12900 MBP
	14	113	68	113										

## Performance tables

R290, 220V/50Hz, CSIR, fan 3m/s, VDE, CCC

	pe		Cooling capacity			COP	EER		P1	I	m
	[°C]	[°F]	[W]	[Btu/h]	[kcal/h]		[Btu/Wh]	[kcal/Wh]			
[°C / °F]	-35	-31	178,1	608	153,2	1,12	3,82	0,96	159,2	1,43	2,00
cond. pressure	-25	-13	294,9	1007	253,8	1,46	4,97	1,25	202,7	1,53	3,33
pc= 45/113	-15	5	450,6	1539	387,8	1,87	6,40	1,61	240,5	1,64	5,13
return gas temp.	-10	14	546,8	1867	470,6	2,13	7,27	1,83	257,0	1,69	6,26
RGT= 32/90	-5	23	657,2	2245	565,6	2,42	8,26	2,08	271,8	1,74	7,57
liquid temp	0	32	783,4	2675	674,2	2,75	9,40	2,37	284,7	1,78	9,09
Tliq= 45/113	7,2	45	995,8	3401	857,0	3,32	11,34	2,86	299,9	1,84	11,70
[°C / °F]	-35	-31	139,7	477	120,3	0,87	2,96	0,74	161,5	1,44	1,73
cond. pressure	-25	-13	251,5	859	216,5	1,17	3,98	1,00	215,7	1,57	3,13
pc= 55/131	-15	5	391,1	1336	336,6	1,48	5,07	1,28	263,4	1,71	4,92
return gas temp	-10	14	475,1	1622	408,9	1,67	5,70	1,44	284,6	1,78	6,01
RGT= 32/90	-5	23	570,5	1948	491,0	1,88	6,41	1,62	303,8	1,85	7,27
liquid temp	0	32	679,0	2319	584,3	2,12	7,23	1,82	320,9	1,91	8,72
Tliq= 55/131	7,2	45	861,0	2940	741,0	2,52	8,60	2,17	341,8	1,99	11,22