

Model

Designation	KLF6.6CNDS	220-240V/50Hz 1~	Sales code:	106h2703
-------------	-------------------	------------------	-------------	-----------------

Compressor design

Oil type	Polyolester	Refrigerant(s)	R290
Oil viscosity	9,7cST	Displacement	6,6cm ³ / 0,4cu.in
Oil quantity	170cm ³ / 5,7fl.oz	Compressors on pallet	100
Refr. charge - tech. limit	200g / 7,1oz		
Free gas volume comp.	1583cm ³ / 53,5fl.oz		
Weight	9,5kg / 20,9lbs		
Motor protection	external		
Winding resistance main	8,4Ω (at 25°C)		
Winding resistance aux	11,9Ω (at 25°C)		
Max. winding temp.	125°C / 257°F		
Max. discharge temp.	130°C / 266°F		
Additional note	Very good robustness against liquid intake. Ice-cube maker optimization - indirect suction intake.		



General - Configurations with KLF6.6CNDS

	Conf. 1
Motorconfiguration	CSIR
Power supply (nominal)	220-240V/50Hz
Number of phases	1
Voltage range	198-254V
Approvals	VDE, CCC
Starting torque	HST
Note	- / -

Applications with KLF6.6CNDS

	Conf. 1
Refrigerant	R290
Application	LBP+MBP
System cooling	fan 3m/s
Hot gas defrost	OK
Long interval pull down	OK

Electrical data - Configurations with KLF6.6CNDS

	Conf. 1
Starting device type	relay
Run capacitor	-/-
Start capacitor	80μF
LRA (locked rotor amps / 4s)	12,3A
RLA (rated load amps / 1s)	2,1A
Cut in current	12,3A

Model

Designation

KLF6.6CNDS

220-240V/50Hz 1~

Sales code:

106h2703

Compressor dimensions

Housing	A Height	182mm / 7,17in
	B Height	175mm / 6,89in
	C Length shell	198mm / 7,8in
	D Length w. cover	238mm / 9,37in
	E Width	160mm / 6,3in

Connectors		Suction	Discharge	Process
		X	Y	Z
Diameter	[mm]	øi 8,11-8,29	øi 6,11-6,29	øi 6,11-6,29
	(i:inside, o:outside) [in]	øi 0,32-0,33	øi 0,24-0,25	øi 0,24-0,25
Material		copper	copper	copper
Horizontal angle	±2°	35°	13°	0°
Vertical angle	±2°	30°	40°	145°
Position l/h/w	[mm]	120/72/57	112/106/81	-97/94/72
	[in]	4,7/2,8/2,2	4,4/4,2/3,2	-3,8/3,7/2,8
Straight tube l.	[mm]	14	14	14
	[in]	0,5	0,5	0,5

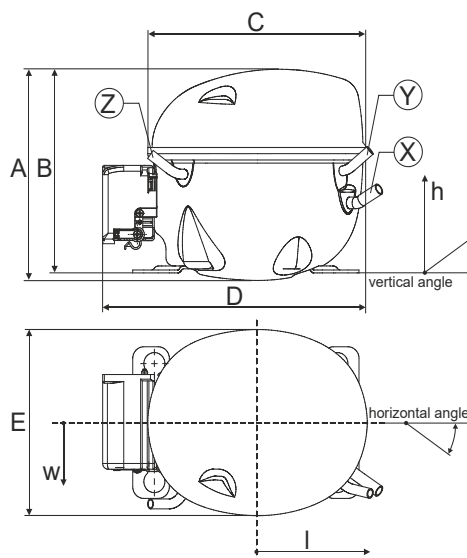

Compressor fixation

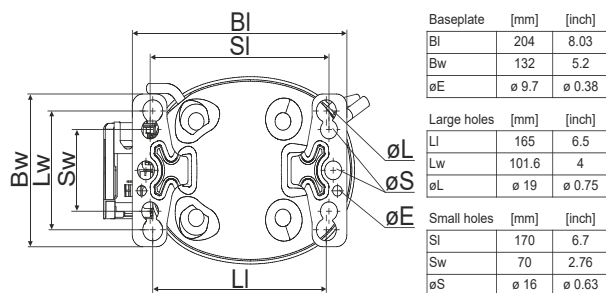

Bolt joint

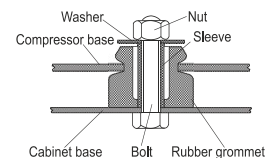

Snap-on

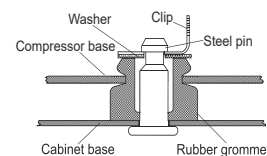

Mounting accessories

Mounting accessories	one comp.	multi pack
Bolt joint M6 ø16mm	118-1917	118-1918
Bolt joint ø1/4" ø16mm	118-1946	
Bolt joint ø1/4" ø19mm	118-1949	
Snap-on ø7,3 ø16mm	118-1947	118-1919

Application notes

Provision for PE Grounding is located at the PE Stamp on the compressor

Model

Designation	KLF6.6CND5	220-240V/50Hz	Conf. 1	Sales code:	106h2703
-------------	-------------------	----------------------	---------	-------------	-----------------

Configuration

Motorconfiguration	CSIR
Power supply (nominal)	220-240V/50Hz 1~
Refrigerant	R290
Application	LBP+MBP
Voltage range	198-254V
Starting torque	HST
Approvals	VDE
	CCC

Electrical accessories / wiring diagram

CSIR

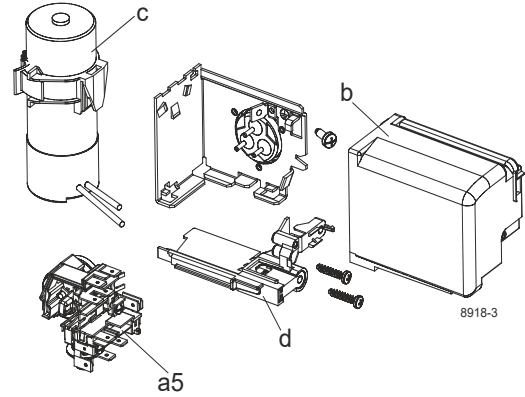

Ambient/ machine room temperatures minimum /maximum

Ambient temperature range: 10 - 43°C / 50 - 110°F

Machine room temperature range: 10 - 48°C / 50 - 119°F

Compressor cooling: fan 3m/s

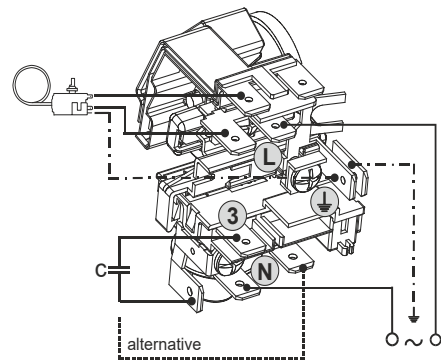

Operation pressure range

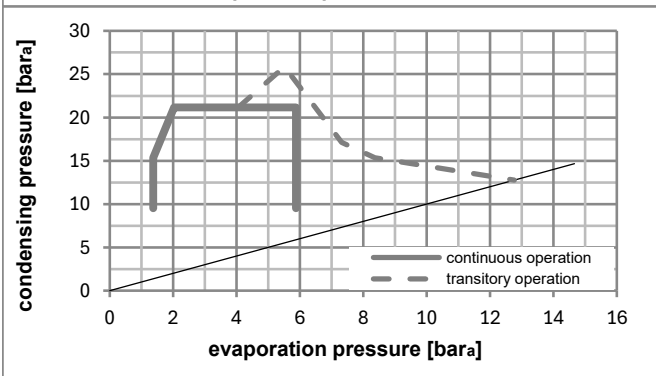
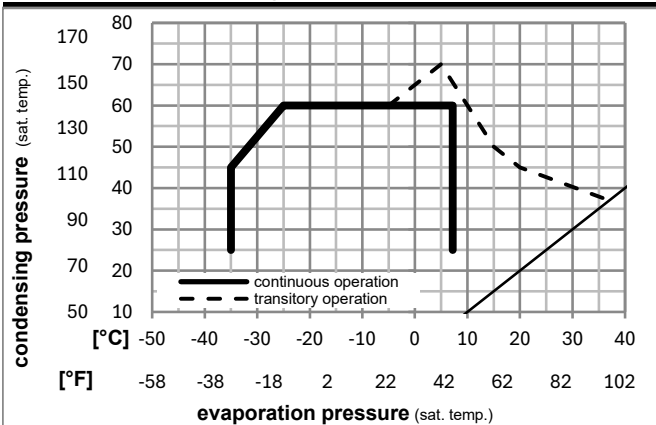

Components

a5	current relay (T0377/L6-S1)	117U7071
c	start capacitor (80μF, 6.3mm)	117U5001
b, d	cover + clamp + screws(5VA) in bag	103N1060

Alternative components

b, d	cover + clamp + screws(5VA-compl.)	103N0600
------	------------------------------------	----------

Model

Designation **KLF6.6CNDS** **220-240V/50Hz** Conf. 1 Sales code: **106h2703**

Optimization + standard conditions

R290, 220V/50Hz, CSIR, fan 3m/s, VDE, CCC

	Evaporating pressure (saturation temperature)				Cooling capacity			COP	EER	P1	Power consumption		ASHRAE LBP	
	pe	pc	RGT	Tliq	[W]	[Btu/h]	[kcal/h]				I	m		
[°C]	-23	54	32	32	325,1	1110	279,8	1,47	5,02	1,26	221,2	1,58	3,29	
[°F]	-10	130	90	90										
[°C]	-25	55	32	55	242,8	829	208,9	1,14	3,88	0,98	213,6	1,55	3,02	cecomaf LBP
[°F]	-13	131	90	131										
[°C]	-35	40	20	40	181,6	620	156,3	1,17	4,01	1,01	154,8	1,41	2,07	EN12900 LBP
[°F]	-31	104	68	104										
[°C]	-7	54	35	46	575,0	1964	494,9	1,96	6,70	1,69	293,1	1,80	6,56	ASHRAE MBP
[°F]	20	130	95	115										
[°C]	-10	55	32	55	458,5	1566	394,6	1,63	5,56	1,40	281,8	1,76	5,80	cecomaf MBP
[°F]	14	131	90	131										
[°C]	-10	45	20	45	506,9	1731	436,2	1,99	6,80	1,71	254,5	1,67	6,22	EN12900 MBP
[°F]	14	113	68	113										

Performance tables

R290, 220V/50Hz, CSIR, fan 3m/s, VDE, CCC

	pe		Cooling capacity			COP	EER		P1	I	m
	[°C]	[°F]	[W]	[Btu/h]	[kcal/h]		[Btu/Wh]	[kcal/Wh]			
[°C / °F]	-35	-31	171,8	587	147,9	1,09	3,72	0,94	157,6	1,42	1,93
cond. pressure	-25	-13	284,6	972	244,9	1,42	4,84	1,22	200,7	1,51	3,21
pc= 45/113	-15	5	434,9	1485	374,3	1,83	6,24	1,57	238,2	1,62	4,95
return gas temp.	-10	14	527,7	1802	454,2	2,07	7,08	1,78	254,5	1,67	6,04
RGT= 32/90	-5	23	634,3	2166	545,9	2,36	8,05	2,03	269,1	1,72	7,30
liquid temp	0	32	756,1	2582	650,7	2,68	9,16	2,31	281,9	1,76	8,77
Tliq= 45/113	7,2	45	961,1	3282	827,1	3,24	11,05	2,79	296,9	1,82	11,29
[°C / °F]	-35	-31	134,9	461	116,1	0,84	2,88	0,73	159,9	1,42	1,67
cond. pressure	-25	-13	242,8	829	208,9	1,14	3,88	0,98	213,6	1,55	3,02
pc= 55/131	-15	5	377,5	1289	324,8	1,45	4,94	1,25	260,9	1,69	4,75
return gas temp	-10	14	458,5	1566	394,6	1,63	5,56	1,40	281,8	1,76	5,80
RGT= 32/90	-5	23	550,6	1880	473,9	1,83	6,25	1,58	300,8	1,83	7,01
liquid temp	0	32	655,3	2238	563,9	2,06	7,04	1,77	317,8	1,89	8,42
Tliq= 55/131	7,2	45	830,9	2838	715,1	2,46	8,39	2,11	338,4	1,97	10,83