

Model

Designation	KLF6.6CNH	115-127V/60Hz 1~	Sales code:	106H3700
-------------	------------------	------------------	-------------	-----------------

Compressor design

Oil type	Polyolester	Refrigerant(s)	R290
Oil viscosity	9,7cST	Displacement	6,6cm ³ / 0,4cu.in
Oil quantity	170cm ³ / 5,7fl.oz	Compressors on pallet	100
Refr. charge - tech. limit	200g / 7,1oz		
Free gas volume comp.	1580cm ³ / 53,4fl.oz		
Weight	9,5kg / 20,9lbs		
Motor protection	external		
Winding resistance main	2Ω (at 25°C)		
Winding resistance aux	5,3Ω (at 25°C)		
Max. winding temp.	125°C / 257°F		
Max. discharge temp.	130°C / 266°F		



General - Configurations with KLF6.6CNH

	Conf. 1	Conf. 2
Motorconfiguration	CSIR	RSCR
Power supply (nominal)	115-127V/60Hz	115-127V/60Hz
Number of phases	1	1
Voltage range	95-140V	95-140V
Approvals	UL, CCC	UL, CCC
Starting torque	HST	LST
Note	LRA value on compressor label and datasheet may differ due to different test conditions for UL approval.	

Applications with KLF6.6CNH

	Conf. 1	Conf. 2
Refrigerant	R290	R290
Application	LBP+MBP	LBP+MBP
System cooling	fan 3m/s	fan 3m/s
Hot gas defrost	OK	OK
Long interval pull down	OK	OK

Electrical data - Configurations with KLF6.6CNH

	Conf. 1	Conf. 2
Starting device type	relay	PTC
Run capacitor	-/-	15μF
Start capacitor	240μF	-/-
LRA (locked rotor amps / 4s)	27,8A	22,9A
RLA (rated load amps / 1s)	4,3A	4,3A
Cut in current	27,8A	31,5A

Model

Designation

KLF6.6CNH

115-127V/60Hz 1~

Sales code:

106H3700

Compressor dimensions

Housing	A Height	182mm / 7,17in
	B Height	175mm / 6,89in
	C Length shell	198mm / 7,8in
	D Length w. cover	238mm / 9,37in
	E Width	160mm / 6,3in

Connectors		Suction	Discharge	Process
		X	Y	Z
Diameter	[mm]	øi 8,11-8,29	øi 6,41-6,59	øi 6,41-6,59
	(i:inside, o:outside) [in]	øi 0,32-0,33	øi 0,25-0,26	øi 0,25-0,26
Material		copper	copper	copper
Horizontal angle	±2°	35°	13°	0°
Vertical angle	±2°	30°	40°	145°
Position l/h/w	[mm]	120/72/57	112/106/81	-97/94/72
	[in]	4,7/2,8/2,2	4,4/4,2/3,2	-3,8/3,7/2,8
Straight tube l.	[mm]	14	14	14
	[in]	0,5	0,5	0,5

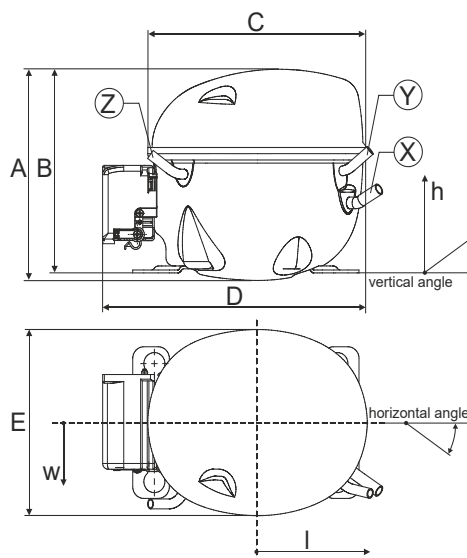

Compressor fixation

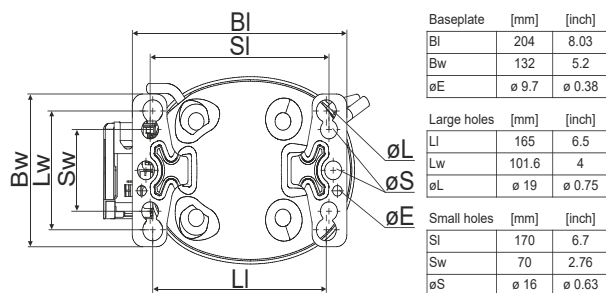

Bolt joint

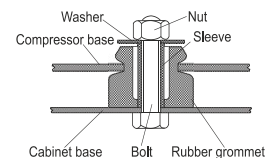

Snap-on

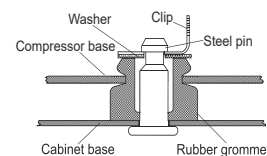

Mounting accessories

	one comp.	multi pack
Bolt joint M6 ø16mm	118-1917	118-1918
Bolt joint ø1/4" ø16mm	118-1946	
Bolt joint ø1/4" ø19mm	118-1949	
Snap-on ø7,3 ø16mm	118-1947	118-1919

Application notes

Provision for PE Grounding is located at the PE Stamp on the compressor

Model

Designation	KLF6.6CNH	115-127V/60Hz	Conf. 1	Sales code:	106H3700
-------------	------------------	----------------------	---------	-------------	-----------------

Configuration

Motorconfiguration	CSIR
Power supply (nominal)	115-127V/60Hz 1~
Refrigerant	R290
Application	LBP+MBP
Voltage range	95-140V
Starting torque	HST
Approvals	UL
	CCC

Electrical accessories / wiring diagram

CSIR

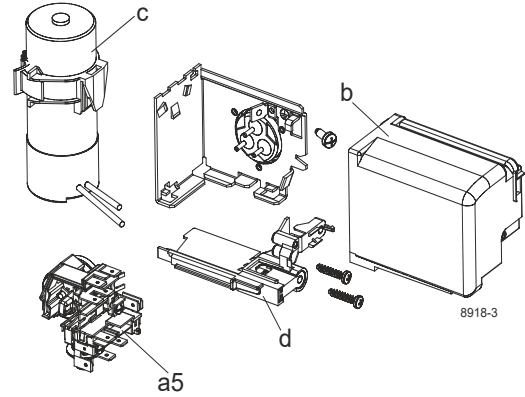

Ambient/ machine room temperatures minimum /maximum

Ambient temperature range: 10 - 43°C / 50 - 110°F

Machine room temperature range: 10 - 48°C / 50 - 119°F

Compressor cooling: fan 3m/s

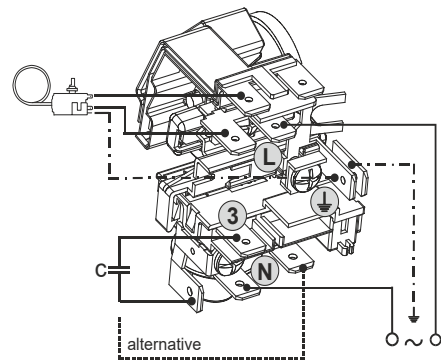

Operation pressure range

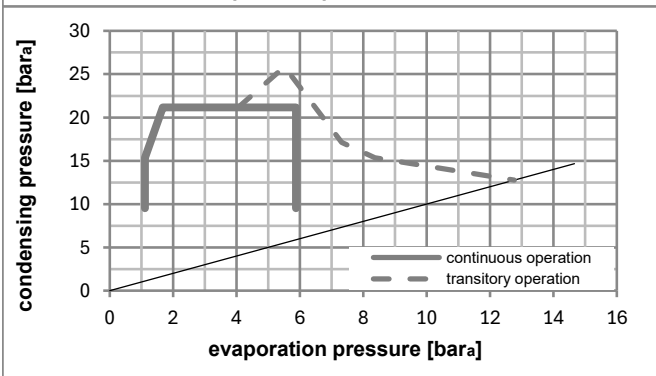
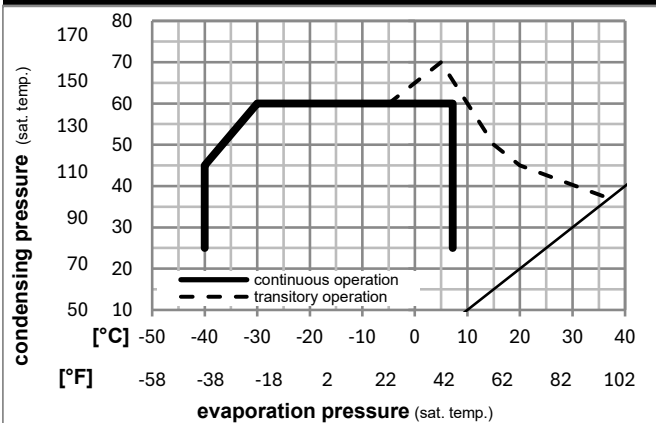

Components

a5	current relay (T1141/L6-S6)	117U7076
c	start capacitor (240µF)	117U5002
b, d	cover + clamp + screws(5VA) in bag	103N1060

Alternative components

b, d	cover + clamp + screws(5VA-compl.)	103N0600
------	------------------------------------	----------

Model

Designation **KLF6.6CNH** **115-127V/60Hz** Conf. 1 Sales code: **106H3700**

Optimization + standard conditions

R290, 115V/60Hz, CSIR, fan 3m/s, UL, CCC

	Evaporating pressure (saturation temperature)				Cooling capacity			COP	EER	P1	Power consumption		ASHRAE LBP	
	pe	pc	RGT	Tliq	[W]	[Btu/h]	[kcal/h]				I	m		
	[°C]	[°F]	[°C]	[°F]	[W]	[Btu/h]	[kcal/h]	[W/W]	[Btu/Wh]	[kcal/Wh]	[W]	[A]	[kg/h]	
	-23	54	32	32	396,9	1355	341,6	1,61	5,51	1,39	246,0	3,18	4,02	ASHRAE LBP
	-10	130	90	90										
	-25	55	32	55	297,2	1015	255,8	1,26	4,30	1,08	236,1	3,13	3,70	cecomaf LBP
	-13	131	90	131										
	-35	40	20	40	224,4	766	193,1	1,20	4,11	1,04	186,5	2,89	2,56	EN12900 LBP
	-31	104	68	104										
	-7	54	35	46	717,6	2451	617,6	2,08	7,09	1,79	345,8	3,84	8,19	ASHRAE MBP
	20	130	95	115										
	-10	55	32	55	567,9	1940	488,8	1,73	5,90	1,49	328,5	3,72	7,18	cecomaf MBP
	14	131	90	131										
	-10	45	20	45	639,3	2183	550,2	2,06	7,02	1,77	311,0	3,60	7,85	EN12900 MBP
	14	113	68	113										

Performance tables

R290, 115V/60Hz, CSIR, fan 3m/s, UL, CCC

	pe		Cooling capacity			COP	EER		P1	I	m
	[°C]	[°F]	[W]	[Btu/h]	[kcal/h]		[Btu/Wh]	[kcal/Wh]			
[°C / °F]	-40	-40	161,8	553	139,2	0,99	3,37	0,85	163,8	2,80	1,81
cond. pressure	-34	-30	220,5	753	189,8	1,17	4,00	1,01	188,3	2,89	2,47
pc= 45/113	-23	-10	381,3	1302	328,2	1,56	5,33	1,34	244,5	3,18	4,31
return gas temp.	-15	5	546,0	1865	469,9	1,90	6,49	1,64	287,3	3,44	6,21
RGT= 32/90	-4	25	834,7	2851	718,3	2,48	8,48	2,14	336,2	3,77	9,62
liquid temp	0	32	956,4	3266	823,1	2,74	9,35	2,36	349,3	3,87	11,09
Tliq= 45/113	7,2	45	1213,8	4145	1044,6	3,32	11,34	2,86	365,7	3,99	14,26
[°C / °F]	-40	-40	139,9	478	120,4	0,92	3,14	0,79	152,3	2,74	1,73
cond. pressure	-34	-30	186,9	638	160,9	1,04	3,54	0,89	180,6	2,84	2,31
pc= 55/131	-23	-10	321,1	1097	276,3	1,30	4,45	1,12	246,4	3,19	4,00
return gas temp	-15	5	463,1	1582	398,6	1,55	5,30	1,34	298,4	3,52	5,82
RGT= 32/90	-4	25	717,9	2452	617,9	1,98	6,77	1,71	362,3	3,97	9,16
liquid temp	0	32	826,9	2824	711,6	2,17	7,40	1,87	381,3	4,11	10,62
Tliq= 55/131	7,2	45	1059,1	3617	911,5	2,58	8,83	2,22	409,7	4,33	13,80

Model

Designation	KLF6.6CNH	115-127V/60Hz	Conf. 2	Sales code:	106H3700
-------------	------------------	----------------------	----------------	-------------	-----------------

Configuration

Motorconfiguration	RSCR
Power supply (nominal)	115-127V/60Hz 1~
Refrigerant	R290
Application	LBP+MBP
Voltage range	95-140V
Starting torque	LST
Approvals	UL CCC

Electrical accessories / wiring diagram

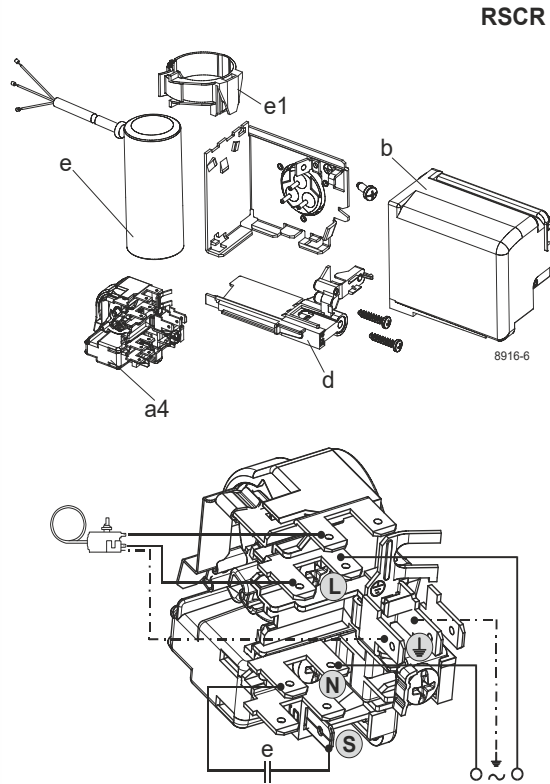

Ambient/ machine room temperatures minimum /maximum

Ambient temperature range:	10 - 43°C / 50 - 110°F
Machine room temperature range:	10 - 48°C / 50 - 119°F
Compressor cooling:	fan 3m/s

Operation pressure range

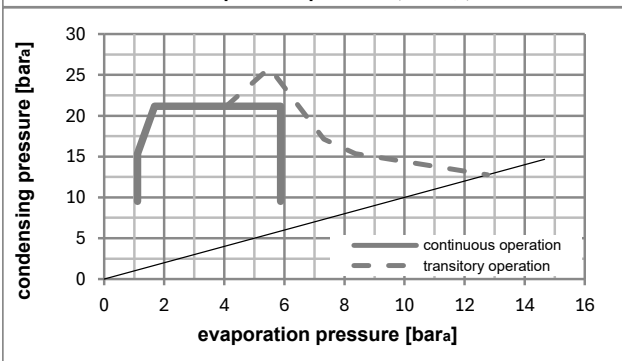
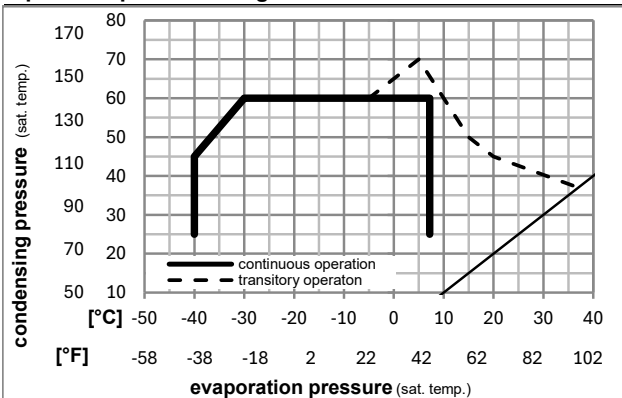

Components

a4	DLS 6 (PTC,6.3mm, T1141/L6 - S6)	103N0214
e	run capacitor (15μF, 6,3mm)	117-7153
b, d	cover + clamp + screws(5VA) in bag	103N1060
e1	retaining clamp	103N0535

Alternative components

b, d	cover + clamp + screws(5VA-compl.)	103N0600
------	------------------------------------	----------

Model

Designation	KLF6.6CNH	115-127V/60Hz	Conf. 2	Sales code:	106H3700
-------------	------------------	----------------------	----------------	-------------	-----------------

Optimization + standard conditions

R290, 115V/60Hz, RSCR, fan 3m/s, UL, CCC

	Evaporating pressure (saturation temperature)				Cooling capacity			COP	EER	P1	Power consumption		Ref. mass flow	
	pe	pc	RGT	Tliq	[W]	[Btu/h]	[kcal/h]				[W]	[A]		
[°C]	-23	54	32	32	398,4	1360	342,8	1,72	5,89	1,48	230,9	2,14	4,03	ASHRAE LBP
[°F]	-10	130	90	90										
[°C]	-25	55	32	55	298,5	1019	256,9	1,35	4,60	1,16	221,5	2,06	3,72	cecomaf LBP
[°F]	-13	131	90	131										
[°C]	-35	40	20	40	227,3	776	195,6	1,32	4,51	1,14	172,2	1,68	2,60	EN12900 LBP
[°F]	-31	104	68	104										
[°C]	-7	54	35	46	716,2	2446	616,3	2,21	7,55	1,90	324,1	2,92	8,17	ASHRAE MBP
[°F]	20	130	95	115										
[°C]	-10	55	32	55	568,4	1941	489,2	1,85	6,31	1,59	307,9	2,78	7,19	cecomaf MBP
[°F]	14	131	90	131										
[°C]	-10	45	20	45	637,4	2177	548,5	2,23	7,62	1,92	285,8	2,59	7,83	EN12900 MBP
[°F]	14	113	68	113										

Performance tables

R290, 115V/60Hz, RSCR, fan 3m/s, UL, CCC

	pe		Cooling capacity			COP	EER	P1	I	m	
	[°C]	[°F]	[W]	[Btu/h]	[kcal/h]						[W/W]
[°C / °F]	-40	-40	166,6	569	143,4	1,09	3,72	0,94	153,0	1,54	1,86
cond. pressure	-34	-30	223,4	763	192,3	1,27	4,35	1,10	175,5	1,70	2,50
pc= 45/113	-23	-10	382,0	1305	328,8	1,69	5,77	1,45	226,3	2,10	4,31
return gas temp.	-15	5	545,3	1862	469,3	2,06	7,04	1,77	264,6	2,41	6,20
RGT= 32/90	-4	25	830,2	2835	714,5	2,69	9,20	2,32	308,3	2,78	9,57
liquid temp	0	32	949,7	3244	817,4	2,97	10,14	2,55	320,0	2,88	11,02
Tliq= 45/113	7,2	45	1201,1	4102	1033,7	3,59	12,25	3,09	334,8	3,01	14,11
[°C / °F]	-40	-40	139,4	476	120,0	0,98	3,33	0,84	143,0	1,45	1,72
cond. pressure	-34	-30	187,0	639	160,9	1,10	3,76	0,95	169,7	1,65	2,31
pc= 55/131	-23	-10	322,5	1102	277,6	1,40	4,76	1,20	231,2	2,14	4,02
return gas temp	-15	5	464,6	1587	399,8	1,66	5,67	1,43	279,7	2,54	5,84
RGT= 32/90	-4	25	715,9	2445	616,1	2,11	7,19	1,81	339,9	3,05	9,14
liquid temp	0	32	822,2	2808	707,6	2,30	7,84	1,98	358,1	3,21	10,56
Tliq= 55/131	7,2	45	1047,1	3576	901,1	2,71	9,26	2,33	386,1	3,45	13,64