

## Model

Designation	<b>KLF6.6CNH</b>	115-127V/60Hz 1~	Sales code:	<b>106H3710</b>
-------------	------------------	------------------	-------------	-----------------

## Compressor design

Oil type	Polyolester	Refrigerant(s)	<b>R290</b>
Oil viscosity	9,7cST	Displacement	6,6cm <sup>3</sup> / 0,4cu.in
Oil quantity	170cm <sup>3</sup> / 5,7fl.oz	Compressors on pallet	100
Refr. charge - tech. limit	200g / 7,1oz		
Free gas volume comp.	1580cm <sup>3</sup> / 53,4fl.oz		
Weight	9,5kg / 20,9lbs		
Motor protection	external		
Winding resistance main	2Ω (at 25°C)		
Winding resistance aux	5,3Ω (at 25°C)		
Max. winding temp.	125°C / 257°F		
Max. discharge temp.	130°C / 266°F		



## General - Configurations with KLF6.6CNH

	<b>Conf. 1</b>
Motorconfiguration	CSIR
Power supply (nominal)	115-127V/60Hz
Number of phases	1
Voltage range	95-140V
Approvals	UL, CCC
Starting torque	HST
Note	Electrical equipment is included and pre-assembled to compressor.

## Applications with KLF6.6CNH

	<b>Conf. 1</b>
Refrigerant	R290
Application	LBP+MBP
System cooling	fan 3m/s
Hot gas defrost	OK
Long interval pull down	OK

## Electrical data - Configurations with KLF6.6CNH

	<b>Conf. 1</b>
Starting device type	relay
Run capacitor	-/-
Start capacitor	240μF
LRA (locked rotor amps / 4s/ U(N))	31,1A
RLA (rated load amps / 1s/ U(N))	4,3A
Cut in current (U(N))	27,8A

## Model

Designation	<b>KLF6.6CNH</b>	115-127V/60Hz 1~	Sales code:	<b>106H3710</b>
-------------	------------------	------------------	-------------	-----------------

## Compressor dimensions

<b>Housing</b>	A Height	182mm / 7,17in
	B Height	175mm / 6,89in
	C Length shell	198mm / 7,8in
	D Length w. cover	238mm / 9,37in
	E Width	160mm / 6,3in

<b>Connectors</b>		<b>Suction</b>	<b>Discharge</b>	<b>Process</b>
		<b>X</b>	<b>Y</b>	<b>Z</b>
Diameter	[mm]	øi 8,11-8,29	øi 6,41-6,59	øi 6,41-6,59
	(i:inside, o:outside) [in]	øi 0,32-0,33	øi 0,25-0,26	øi 0,25-0,26
Material		copper	copper	copper
Horizontal angle	±2°	35°	13°	0°
Vertical angle	±2°	30°	40°	145°
Position l/h/w	[mm]	120/72/57	112/106/81	-97/94/72
	[in]	4,7/2,8/2,2	4,4/4,2/3,2	-3,8/3,7/2,8
Straight tube l.	[mm]	14	14	14
	[in]	0,5	0,5	0,5

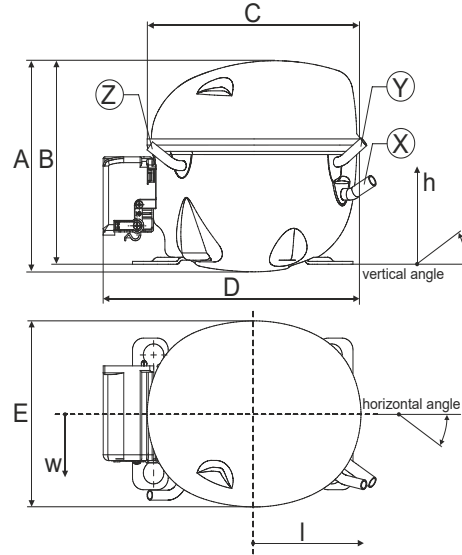

## Compressor fixation

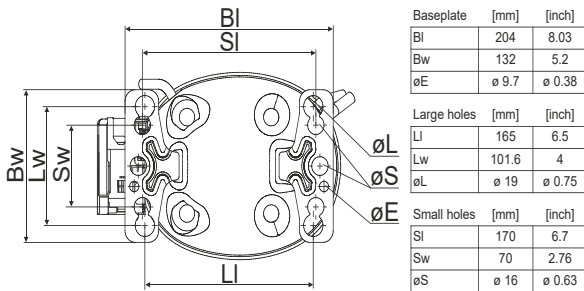

### Bolt joint

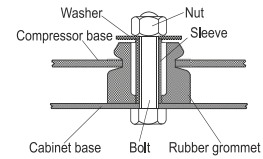

### Snap-on

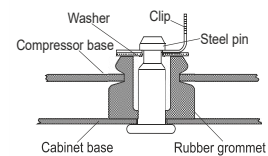

<b>Mounting accessories</b>	one comp.	multi pack
Bolt joint   M6   ø16mm	118-1917	118-1918
Bolt joint   ø1/4"   ø16mm	118-1946	
Bolt joint   ø1/4"   ø19mm	118-1949	
Snap-on   ø7,3   ø16mm	118-1947	118-1919

## Application notes

Operation possible until tilted up to 3 degrees

Provision for PE Grounding is located at the PE Stamp on the compressor

### Model

Designation	<b>KLF6.6CNH</b>	<b>115-127V/60Hz</b>	Conf. 1	Sales code:	<b>106H3710</b>
-------------	------------------	----------------------	---------	-------------	-----------------

### Configuration

Motorconfiguration	CSIR
Power supply (nominal)	115-127V/60Hz 1~
Refrigerant	R290
Application	LBP+MBP
Voltage range	95-140V
Starting torque	HST
Approvals	UL CCC

### Electrical accessories / wiring diagram

CSIR

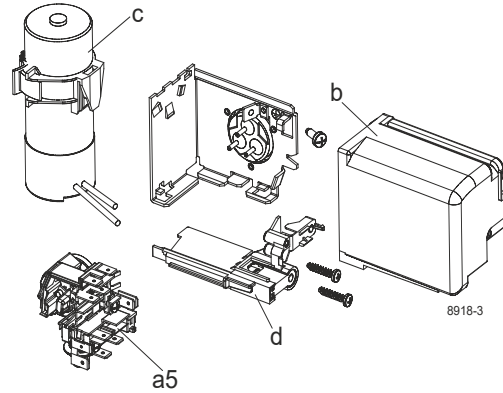

### Ambient/ machine room temperatures minimum /maximum

Ambient temperature range:	10 - 43°C / 50 - 110°F
Machine room temperature range:	10 - 48°C / 50 - 119°F
Compressor cooling:	fan 3m/s

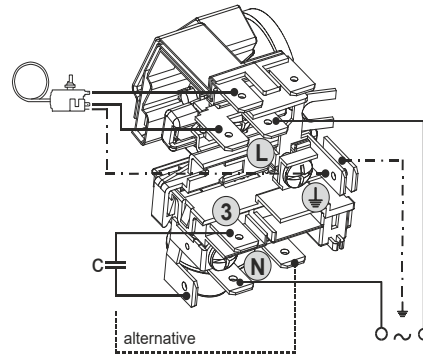

### Operation pressure range

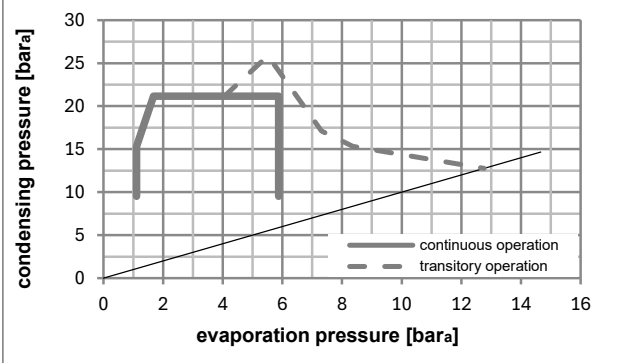
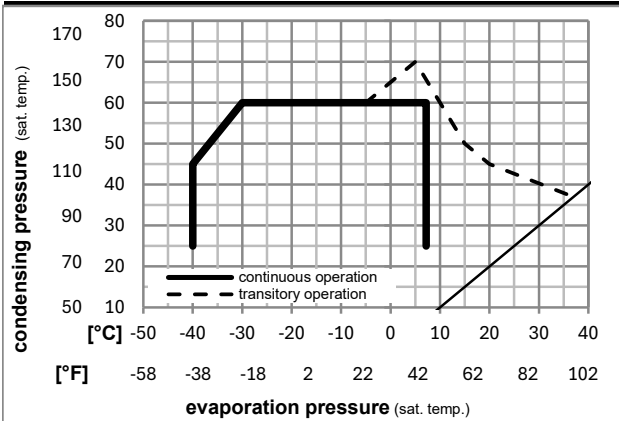

### Components (already pre-assembled)

a5	current relay (T1141/L6-S6)	117U7076
c	start capacitor (240µF)	117U5002
.	cable clamp (screws not included)	16058100
b	cover terminal board	10636401
.	screw uni en iso 4757	10641201
.	screw - uni6954	10636000

### Alternative comp. (already pre-assembled)

.	screw - uni6954	10636200
---	-----------------	----------

## Model

Designation **KLF6.6CNH** **115-127V/60Hz** Conf. 1 Sales code: **106H3710**

## Optimization + standard conditions

R290, 115V/60Hz, CSIR, fan 3m/s, UL, CCC

Evaporating pressure (saturation temperature)				Condensing pressure (saturation temperature)			Power consumption				Current consumption		Ref. mass flow ṁ	
pe	pc	RGT	Tliq	Cooling capacity	COP	EER	P1	I						
[°C]	[°C]	[°C]	[°C]	[W]	[Btu/h]	[kcal/h]	[W/W]	[Btu/Wh]	[kcal/Wh]	[W]	[A]	[kg/h]		
[°C]	-23	54	32	32	396,9	1355	341,6	1,61	5,51	1,39	246,0	3,18	4,02	ASHRAE LBP
[°F]	-10	130	90	90										
[°C]	-25	55	32	55	297,2	1015	255,8	1,26	4,30	1,08	236,1	3,13	3,70	cecomaf LBP
[°F]	-13	131	90	131										
[°C]	-35	40	20	40	224,4	766	193,1	1,20	4,11	1,04	186,5	2,89	2,56	EN12900 LBP
[°F]	-31	104	68	104										
[°C]	-7	54	35	46	717,6	2451	617,6	2,08	7,09	1,79	345,8	3,84	8,19	ASHRAE MBP
[°F]	20	130	95	115										
[°C]	-10	55	32	55	567,9	1940	488,8	1,73	5,90	1,49	328,5	3,72	7,18	cecomaf MBP
[°F]	14	131	90	131										
[°C]	-10	45	20	45	639,3	2183	550,2	2,06	7,02	1,77	311,0	3,60	7,85	EN12900 MBP
[°F]	14	113	68	113										

## Performance tables

R290, 115V/60Hz, CSIR, fan 3m/s, UL, CCC

	pe		Cooling capacity			COP	EER	P1	I	m	
	[°C]	[°F]	[W]	[Btu/h]	[kcal/h]	[W/W]	[Btu/Wh]	[kcal/Wh]	[W]	[A]	[kg/h]
[°C / °F]	-40	-40	161,8	553	139,2	0,99	3,37	0,85	163,8	2,80	1,81
cond. pressure	-34	-30	220,5	753	189,8	1,17	4,00	1,01	188,3	2,89	2,47
pc= 45/113	-23	-10	381,3	1302	328,2	1,56	5,33	1,34	244,5	3,18	4,31
return gas temp.	-15	5	546,0	1865	469,9	1,90	6,49	1,64	287,3	3,44	6,21
RGT= 32/90	-4	25	834,7	2851	718,3	2,48	8,48	2,14	336,2	3,77	9,62
liquid temp	0	32	956,4	3266	823,1	2,74	9,35	2,36	349,3	3,87	11,09
Tliq= 45/113	7,2	45	1213,8	4145	1044,6	3,32	11,34	2,86	365,7	3,99	14,26
[°C / °F]	-40	-40	139,9	478	120,4	0,92	3,14	0,79	152,3	2,74	1,73
cond. pressure	-34	-30	186,9	638	160,9	1,04	3,54	0,89	180,6	2,84	2,31
pc= 55/131	-23	-10	321,1	1097	276,3	1,30	4,45	1,12	246,4	3,19	4,00
return gas temp.	-15	5	463,1	1582	398,6	1,55	5,30	1,34	298,4	3,52	5,82
RGT= 32/90	-4	25	717,9	2452	617,9	1,98	6,77	1,71	362,3	3,97	9,16
liquid temp	0	32	826,9	2824	711,6	2,17	7,40	1,87	381,3	4,11	10,62
Tliq= 55/131	7,2	45	1059,1	3617	911,5	2,58	8,83	2,22	409,7	4,33	13,80