

Model

Designation	KLF6.6CNHS	115-127V/60Hz 1~	Sales code:	106H3713
-------------	-------------------	------------------	-------------	-----------------

Compressor design

Oil type	Polyolester	Refrigerant(s)	R290
Oil viscosity	10,4cSt	Displacement	6,6cm ³ / 0,4cu.in
Oil quantity	174cm ³ / 5,9fl.oz	Compressors on pallet	100
Refr. charge - tech. limit	200g / 7,1oz		
Free gas volume comp.	1580cm ³ / 53,4fl.oz		
Weight	9,5kg / 20,9lbs		
Motor protection	external		
Winding resistance main	2Ω (at 25°C)		
Winding resistance aux	5,3Ω (at 25°C)		
Max. winding temp.	125°C / 257°F		
Max. discharge temp.	130°C / 266°F		
Additional note	Very good robustness against liquid intake. Ice-cube maker optimization - indirect suction intake.		



General - Configurations with KLF6.6CNHS

	Conf. 1
Motorconfiguration	CSIR
Power supply (nominal)	115-127V/60Hz
Number of phases	1
Voltage range	95-140V
Approvals	UL, CCC
Starting torque	HST
Note	Electrical equipment is included and pre-assembled to compressor.

Applications with KLF6.6CNHS

	Conf. 1
Refrigerant	R290
Application	LBP+MBP
System cooling	fan 3m/s
Hot gas defrost	OK
Long interval pull down	OK

Electrical data - Configurations with KLF6.6CNHS

	Conf. 1
Starting device type	relay
Run capacitor	-/-
Start capacitor	240μF
LRA (locked rotor amps / 4s/ U(N))	31,1A
RLA (rated load amps / 1s/ U(N))	4,3A
Cut in current (U(N))	27,8A

Model

Designation	KLF6.6CNHS	115-127V/60Hz 1~	Sales code:	106H3713
-------------	-------------------	------------------	-------------	-----------------

Compressor dimensions

Housing	A Height	182mm / 7,17in
	B Height	175mm / 6,89in
	C Length shell	198mm / 7,8in
	D Length w. cover	238mm / 9,37in
	E Width	160mm / 6,3in

Connectors		Suction	Discharge	Process
		X	Y	Z
Diameter	[mm]	øi 8,11-8,29	øi 6,41-6,59	øi 6,41-6,59
(i:inside, o:outside)	[in]	øi 0,32-0,33	øi 0,25-0,26	øi 0,25-0,26
Material		copper	copper	copper
Horizontal angle	±2°	35°	13°	0°
Vertical angle	±2°	30°	40°	145°
Position l/h/w	[mm]	119/73/59	117/107/66	-88/101/71
	[in]	4,7/2,9/2,3	4,6/4,2/2,6	-3,5/4/2,8
Straight tube l.	[mm]	14	14	14
	[in]	0,5	0,5	0,5

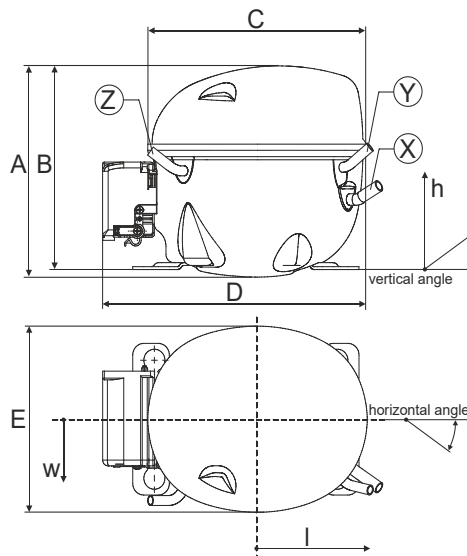

Compressor fixation



Bolt joint



Snap-on

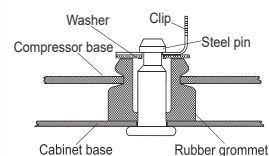

Mounting accessories	one comp.	multi pack
Bolt joint M6 ø16mm	118-1917	118-1918
Bolt joint ø1/4" ø16mm	118-1946	
Bolt joint ø1/4" ø19mm	118-1949	
Snap-on ø7,3 ø16mm	118-1947	118-1919

Application notes

Provision for PE Grounding is located at the PE Stamp on the compressor

Model

Designation	KLF6.6CNHS	115-127V/60Hz	Conf. 1	Sales code:	106H3713
-------------	-------------------	----------------------	----------------	-------------	-----------------

Configuration

Motorconfiguration	CSIR
Power supply (nominal)	115-127V/60Hz 1~
Refrigerant	R290
Application	LBP+MBP
Voltage range	95-140V
Starting torque	HST
Approvals	UL CCC

Electrical accessories / wiring diagram

CSIR



Ambient/ machine room temperatures minimum /maximum

Ambient temperature range:	10 - 43°C / 50 - 110°F
Machine room temperature range:	10 - 48°C / 50 - 119°F
Compressor cooling:	fan 3m/s

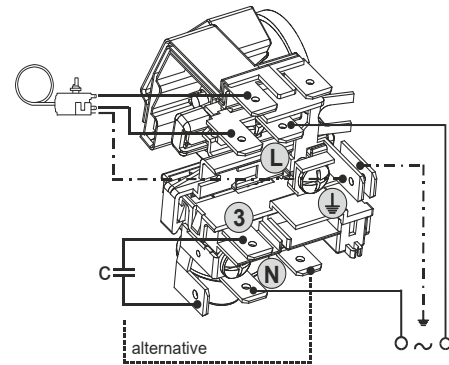

Operation pressure range

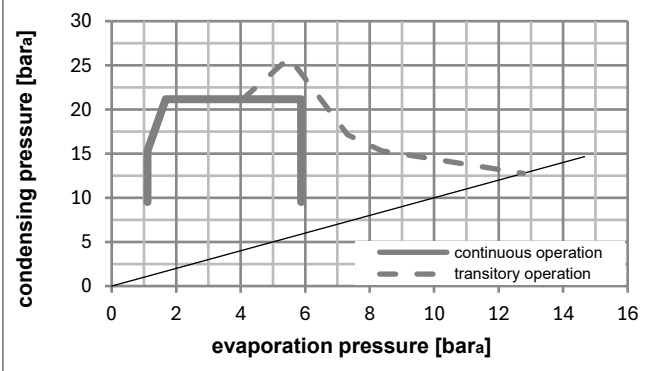
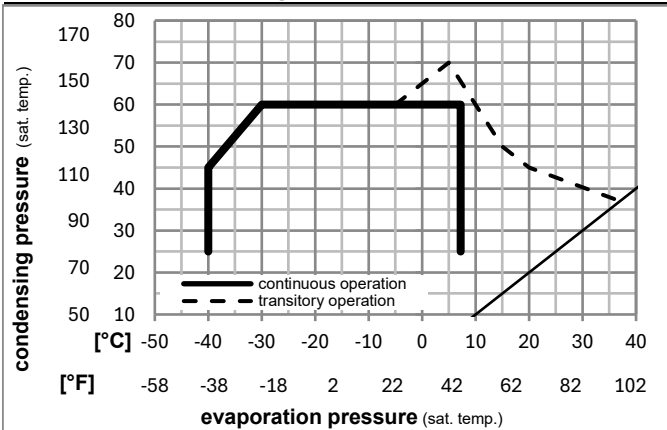

Components (already pre-assembled)

a5	current relay (T1141/L6-S6)	117U7076
c	start capacitor (240µF)	117U5002
b, d	cover + clamp + screws(5VA) in bag	103N1060

Alternative comp. (already pre-assembled)

b, d	100x cover + clamp + screws(5VA)	103N2060
b, d	cover + clamp + screws(5VA-compl.)	103N0600

Model

Designation **KLF6.6CNHS 115-127V/60Hz** Conf. 1 Sales code: **106H3713**

Optimization + standard conditions

R290, 115V/60Hz, CSIR, fan 3m/s, UL, CCC

	Evaporating pressure (saturation temperature)				Cooling capacity			COP	EER	P1	Power consumption		ASHRAE LBP	
	pe	pc	RGT	Tliq	[W]	[Btu/h]	[kcal/h]				I	m		
	[°C]	[°C]	[°C]	[°C]				[W/W]	[Btu/Wh]	[kcal/Wh]	[W]	[A]	[kg/h]	
	-23	54	32	32	383,0	1308	329,6	1,57	5,37	1,35	243,4	3,15	3,88	ASHRAE LBP
	[°F]													
	-10	130	90	90										
	-25	55	32	55	286,8	979	246,8	1,23	4,19	1,06	233,6	3,09	3,57	cecomaf LBP
	[°F]													
	-13	131	90	131										
	-35	40	20	40	216,5	740	186,4	1,17	4,01	1,01	184,6	2,86	2,47	EN12900 LBP
	[°F]													
	-31	104	68	104										
	-7	54	35	46	692,4	2365	595,9	2,02	6,91	1,74	342,3	3,80	7,90	ASHRAE MBP
	[°F]													
	20	130	95	115										
	-10	55	32	55	548,0	1872	471,6	1,69	5,76	1,45	325,1	3,68	6,93	cecomaf MBP
	[°F]													
	14	131	90	131										
	-10	45	20	45	616,9	2107	530,9	2,00	6,84	1,72	307,8	3,56	7,57	EN12900 MBP
	[°F]													
	14	113	68	113										

Performance tables

R290, 115V/60Hz, CSIR, fan 3m/s, UL, CCC

	pe		Cooling capacity			COP	EER	P1	I	m	
	[°C]	[°F]	[W]	[Btu/h]	[kcal/h]						
[°C / °F]	-40	-40	156,1	533	134,3	0,96	3,29	0,83	162,1	2,78	1,75
cond. pressure	-34	-30	212,8	727	183,1	1,14	3,90	0,98	186,4	2,86	2,39
pc= 45/113	-23	-10	367,9	1257	316,6	1,52	5,19	1,31	242,0	3,14	4,15
return gas temp.	-15	5	526,9	1799	453,4	1,85	6,33	1,59	284,3	3,40	5,99
RGT= 32/90	-4	25	805,4	2751	693,1	2,42	8,27	2,08	332,8	3,73	9,29
liquid temp	0	32	922,9	3152	794,2	2,67	9,12	2,30	345,7	3,83	10,70
Tliq= 45/113	7,2	45	1171,2	4000	1008,0	3,24	11,05	2,79	361,9	3,95	13,76
[°C / °F]	-40	-40	135,0	461	116,2	0,90	3,06	0,77	150,7	2,71	1,67
cond. pressure	-34	-30	180,4	616	155,2	1,01	3,45	0,87	178,7	2,81	2,23
pc= 55/131	-23	-10	309,8	1058	266,7	1,27	4,34	1,09	243,9	3,15	3,86
return gas temp	-15	5	446,9	1526	384,6	1,51	5,17	1,30	295,3	3,48	5,62
RGT= 32/90	-4	25	692,7	2366	596,2	1,93	6,60	1,66	358,6	3,92	8,84
liquid temp	0	32	797,9	2725	686,6	2,11	7,22	1,82	377,4	4,07	10,25
Tliq= 55/131	7,2	45	1022,0	3490	879,5	2,52	8,61	2,17	405,5	4,29	13,31