

## Model

Designation	<b>KLF6.6MFT</b>	200-240V/50Hz 1~ 208-230V/60Hz 1~	Sales code:	<b>106G2711</b>
-------------	------------------	-----------------------------------	-------------	-----------------

## Compressor design

Oil type	Polyolester	Refrigerant(s)	<b>R134a</b>
Oil viscosity	9,7cST	Displacement	6,6cm <sup>3</sup> / 0,4cu.in
Oil quantity	170cm <sup>3</sup> / 5,7fl.oz	Compressors on pallet	100
Refr. charge - tech. limit	400g / 14,1oz		
Free gas volume comp.	1580cm <sup>3</sup> / 53,4fl.oz		
Weight	9,4kg / 20,7lbs		
Motor protection	external		
Winding resistance main	8,4Ω (at 25°C)		
Winding resistance aux	11,9Ω (at 25°C)		
Max. winding temp.	125°C / 257°F		
Max. discharge temp.	130°C / 266°F		



## General - Configurations with KLF6.6MFT

	<b>Conf. 1</b>	<b>Conf. 2</b>
Motorconfiguration	CSIR	CSIR
Power supply (nominal)	200-240V/50Hz	208-230V/60Hz
Number of phases	1	1
Voltage range	170-254V	198-253V
Approvals	VDE, UL, CCC	VDE, UL, CCC
Starting torque	HST	HST
Note	Electrical equipment is included and pre-assembled to compressor.	

## Applications with KLF6.6MFT

	<b>Conf. 1</b>	<b>Conf. 2</b>
Refrigerant	R134a	R134a
Application	MBP	MBP
System cooling	fan 3m/s	fan 3m/s
Hot gas defrost	OK	OK
Long interval pull down	OK	OK

## Electrical data - Configurations with KLF6.6MFT

	<b>Conf. 1</b>	<b>Conf. 2</b>
Starting device type	relay	relay
Run capacitor	-/-	-/-
Start capacitor	80μF	80μF
LRA (locked rotor amps / 4s)	12,3A	12,3A
RLA (rated load amps / 1s)	2,1A	2,1A
Cut in current	12,3A	12,3A

## Model

Designation	<b>KLF6.6MFT</b>	200-240V/50Hz 1~ 208-230V/60Hz 1~	Sales code:	<b>106G2711</b>
-------------	------------------	-----------------------------------	-------------	-----------------

## Compressor dimensions

<b>Housing</b>	A Height	182mm / 7,17in
	B Height	175mm / 6,89in
	C Length shell	198mm / 7,8in
	D Length w. cover	238mm / 9,37in
	E Width	160mm / 6,3in

<b>Connectors</b>		<b>Suction</b>	<b>Discharge</b>	<b>Process</b>
		<b>X</b>	<b>Y</b>	<b>Z</b>
Diameter	[mm]	øi 8,11-8,29	øi 6,11-6,29	øi 6,11-6,29
	(i:inside, o:outside) [in]	øi 0,32-0,33	øi 0,24-0,25	øi 0,24-0,25
Material		copper	copper	copper
Horizontal angle	±2°	35°	13°	0°
Vertical angle	±2°	30°	40°	145°
Position l/h/w	[mm]	120/72/57	112/106/81	-97/94/72
	[in]	4,7/2,8/2,2	4,4/4,2/3,2	-3,8/3,7/2,8
Straight tube l.	[mm]	14	14	14
	[in]	0,5	0,5	0,5

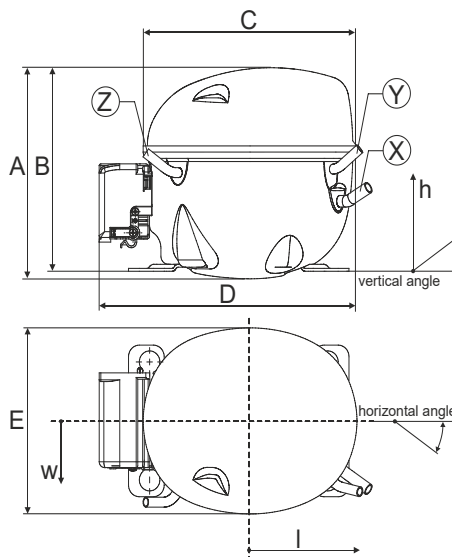

## Compressor fixation

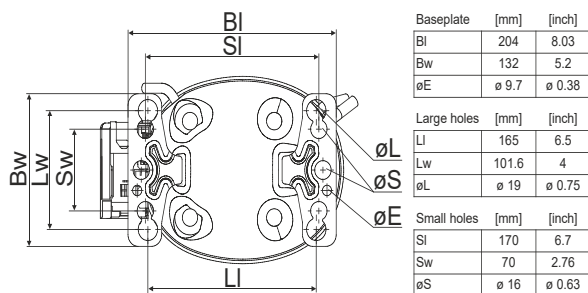

### Bolt joint

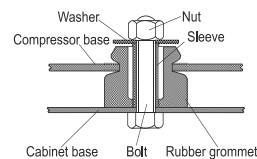

### Snap-on

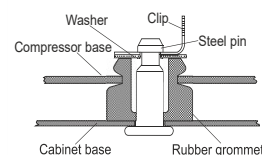

<b>Mounting accessories</b>	one comp.	multi pack
Bolt joint   M6   ø16mm	118-1917	118-1918
Bolt joint   ø1/4"   ø16mm	118-1946	
Bolt joint   ø1/4"   ø19mm	118-1949	
Snap-on   ø7,3   ø16mm	118-1947	118-1919

## Application notes

Provision for PE Grounding is located at the PE Stamp on the compressor

LRA value on compressor label and datasheet may differ due to different test conditions for UL approval.

Compressor can operate safely in LBP, no official third-party approval yet

## Model

Designation	<b>KLF6.6MFT</b>	<b>200-240V/50Hz</b>	Conf. 1	Sales code:	<b>106G2711</b>
-------------	------------------	----------------------	---------	-------------	-----------------

## Configuration

Motorconfiguration	CSIR
Power supply (nominal)	200-240V/50Hz 1~
Refrigerant	R134a
Application	MBP
Voltage range	170-254V
Starting torque	HST
Approvals	VDE
	UL
	CCC

## Electrical accessories / wiring diagram

CSIR

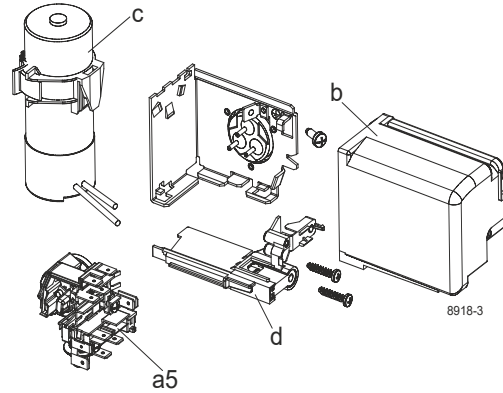

## Ambient/ machine room temperatures minimum /maximum

Ambient temperature range:	10 - 43°C / 50 - 110°F
Machine room temperature range:	10 - 48°C / 50 - 119°F
Compressor cooling:	fan 3m/s

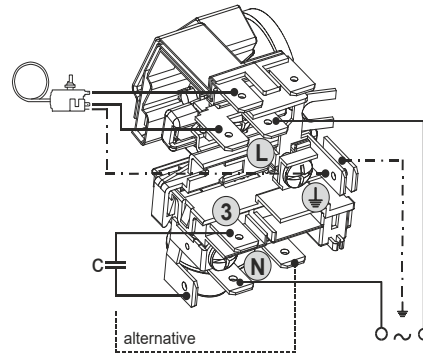

## Operation pressure range

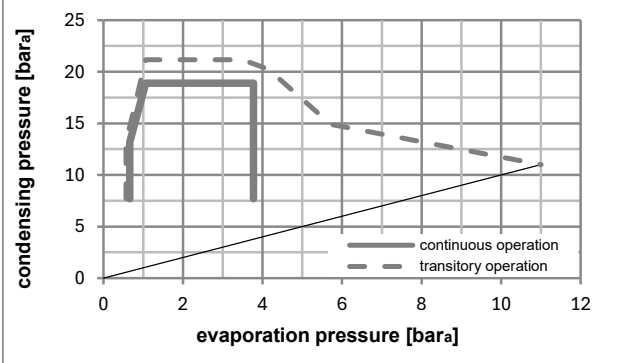
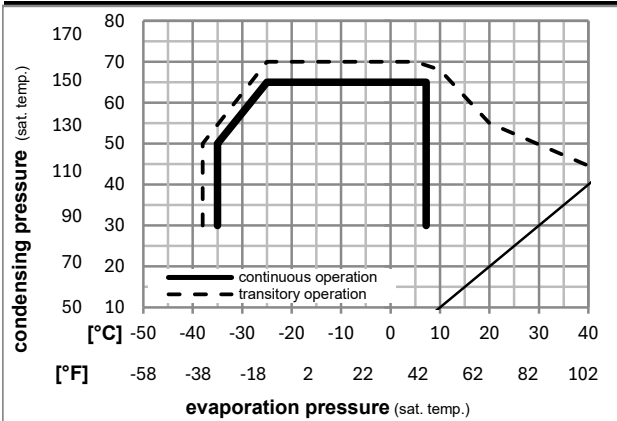

### Components (already pre-assembled)

a5	current relay (T0377/L6-S1)	117U7071
c	start capacitor (80µF, 6.3mm)	117U5001
b	cover terminal board	10636401
.	screw uni en iso 4757	10641201

### Alternative comp. (already pre-assembled)

.	cable clamp (screws not included)	16058100
.	screw - uni6954	10636000
.	screw - uni6954	10636200

## Model

Designation **KLF6.6MFT** **200-240V/50Hz** Conf. 1 Sales code: **106G2711**

## Optimization + standard conditions

R134a, 200V/50Hz, CSIR, fan 3m/s, VDE, UL, CCC

Evaporating pressure (saturation temperature)					Condensing pressure (saturation temperature)						Power consumption			ASHRAE MBP
Return gas temp.				Liquid temp.		Cooling capacity	COP	EER	P1	Current consumption		Ref. mass flow		
pe	pc	RGT	Tliq	[W]	[Btu/h]					[kcal/h]	[W/W]		[Btu/Wh]	
[°C]	[°C]	[°C]	[°C]	[W]	[Btu/h]	[kcal/h]	[W/W]	[Btu/Wh]	[kcal/Wh]	[W]	[A]	[kg/h]		
-7	54	35	46	401,5	1371	345,5	1,92	6,57	1,65	208,8	1,49	8,76	ASHRAE MBP	
[°F]	20	130	95	115										
-10	55	32	55	309,8	1058	266,6	1,58	5,41	1,36	195,8	1,45	7,49	cecomaf MBP	
[°F]	14	131	90	131										
-10	45	20	45	347,3	1186	298,9	1,94	6,64	1,67	178,7	1,38	8,13	EN12900 MBP	
[°F]	14	113	68	113										
-7	49	18	49	380,5	1299	327,4	1,92	6,56	1,65	198,1	1,45	9,40	ARI540 MBP	
[°F]	20	120	65	120										
-10	45	32	45	360,3	1230	310,1	2,02	6,88	1,73	178,7	1,38	7,89	opt	
[°F]	14	113	90	113										
-25	45	32	45	161,0	550	138,6	1,27	4,33	1,09	126,9	1,24	3,49	opt	
[°F]	-13	113	90	113										

## Performance tables

R134a, 200V/50Hz, CSIR, fan 3m/s, VDE, UL, CCC

	pe		Cooling capacity			COP	EER	P1	I	m	
	[°C]	[°F]	[W]	[Btu/h]	[kcal/h]	[W/W]	[Btu/Wh]				[kcal/Wh]
[°C / °F]	-30	-22	118,8	406	102,3	1,09	3,72	0,94	109,1	1,20	2,57
cond. pressure	-25	-13	161,0	550	138,6	1,27	4,33	1,09	126,9	1,24	3,49
pc= 45/113	-15	5	280,8	959	241,7	1,74	5,94	1,50	161,6	1,33	6,12
return gas temp.	-10	14	360,3	1230	310,1	2,02	6,88	1,73	178,7	1,38	7,89
RGT= 32/90	-5	23	454,0	1550	390,7	2,32	7,92	1,99	195,9	1,44	9,98
liquid temp	0	32	562,7	1922	484,3	2,64	9,02	2,27	213,1	1,51	12,45
Tliq= 45/113	7,2	45	747,8	2554	643,5	3,14	10,71	2,70	238,5	1,60	16,70
[°C / °F]	-30	-22	99,2	339	85,3	0,92	3,14	0,79	107,7	1,19	2,37
cond. pressure	-25	-13	136,5	466	117,4	1,04	3,57	0,90	130,6	1,25	3,26
pc= 55/131	-15	5	240,9	823	207,3	1,38	4,71	1,19	174,5	1,37	5,80
return gas temp.	-10	14	309,8	1058	266,6	1,58	5,41	1,36	195,8	1,45	7,49
RGT= 32/90	-5	23	391,1	1336	336,6	1,80	6,16	1,55	216,7	1,52	9,51
liquid temp	0	32	485,6	1658	417,9	2,04	6,98	1,76	237,5	1,60	11,88
Tliq= 55/131	7,2	45	646,7	2209	556,5	2,42	8,26	2,08	267,3	1,72	15,99

## Model

Designation	<b>KLF6.6MFT</b>	<b>208-230V/60Hz</b>	<b>Conf. 2</b>	Sales code:	<b>106G2711</b>
-------------	------------------	----------------------	----------------	-------------	-----------------

## Configuration

Motorconfiguration	CSIR
Power supply (nominal)	208-230V/60Hz 1~
Refrigerant	R134a
Application	MBP
Voltage range	198-253V
Starting torque	HST
Approvals	VDE
	UL
	CCC

## Electrical accessories / wiring diagram

**CSIR**

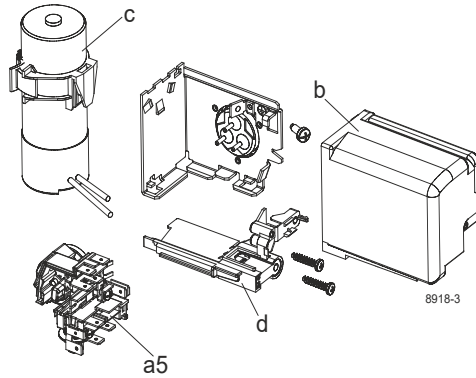

## Ambient/ machine room temperatures minimum /maximum

Ambient temperature range:	10 - 43°C / 50 - 110°F
Machine room temperature range:	10 - 48°C / 50 - 119°F
Compressor cooling:	fan 3m/s

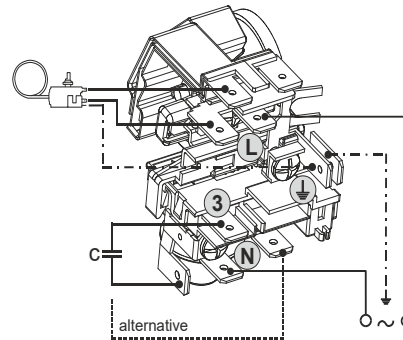

## Operation pressure range

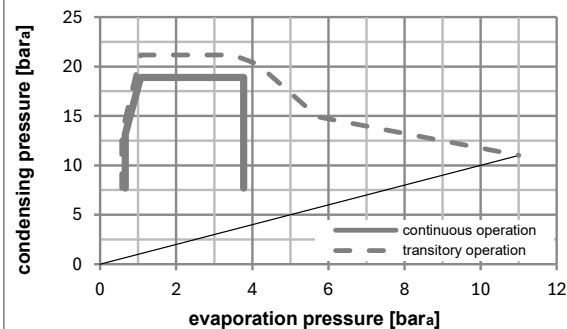
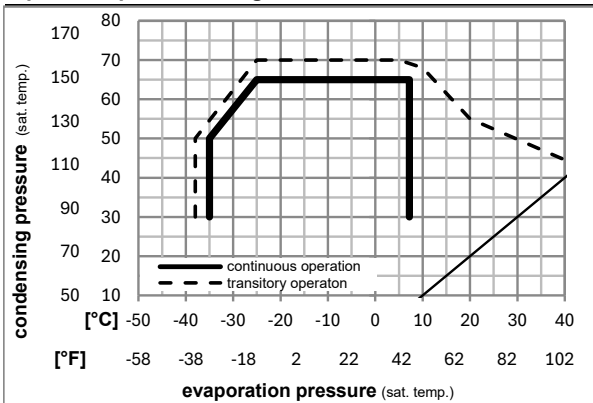

## Components (already pre-assembled)

a5	current relay (T0377/L6-S1)	117U7071
c	start capacitor (80µF, 6.3mm)	117U5001
b	cover terminal board	10636401
.	screw uni en iso 4757	10641201

## Alternative comp. (already pre-assembled)

.	cable clamp (screws not included)	16058100
.	screw - uni6954	10636000
.	screw - uni6954	10636200

## Model

Designation	<b>KLF6.6MFT</b>	<b>208-230V/60Hz</b>	<b>Conf. 2</b>	Sales code:	<b>106G2711</b>
-------------	------------------	----------------------	----------------	-------------	-----------------

## Optimization + standard conditions

R134a, 208V/60Hz, CSIR, fan 3m/s, VDE, UL, CCC

		Evaporating pressure (saturation temperature)				Condensing pressure (saturation temperature)						Power consumption			
		Return gas temp.				Liquid temp.						Current consumption		Ref. mass flow	
		Cooling capacity				COP	EER		P1	I	m				
		pe	pc	RGT	Tliq	[W]	[Btu/h]	[kcal/h]	[W/W]	[Btu/Wh]	[kcal/Wh]	[W]	[A]	[kg/h]	
[°C]	-7	54	35	46	474,8	1621	408,6	1,95	6,66	1,68	243,4	1,48	10,36	<b>ASHRAE MBP</b>	
[°F]	20	130	95	115											
[°C]	-10	55	32	55	367,4	1255	316,2	1,61	5,51	1,39	227,7	1,43	8,88	<b>cecomaf MBP</b>	
[°F]	14	131	90	131											
[°C]	-10	45	20	45	405,5	1385	349,0	1,93	6,58	1,66	210,6	1,37	9,49	<b>EN12900 MBP</b>	
[°F]	14	113	68	113											
[°C]	-7	49	18	49	446,7	1526	384,4	1,91	6,53	1,65	233,5	1,45	11,03	<b>ARI540 MBP</b>	
[°F]	20	120	65	120											
[°C]	-10	45	32	45	420,7	1437	362,1	2,00	6,82	1,72	210,6	1,37	9,21	<b>opt</b>	
[°F]	14	113	90	113											
[°C]	-25	45	32	45	187,1	639	161,0	1,29	4,41	1,11	144,8	1,19	4,05	<b>opt</b>	
[°F]	-13	113	90	113											

## Performance tables

R134a, 208V/60Hz, CSIR, fan 3m/s, VDE, UL, CCC

	pe		Cooling capacity			COP	EER		P1	I	m
	[°C]	[°F]	[W]	[Btu/h]	[kcal/h]	[W/W]	[Btu/Wh]	[kcal/Wh]	[W]	[A]	[kg/h]
[°C / °F]	-30	-22	137,5	470	118,3	1,11	3,80	0,96	123,5	1,14	2,97
cond. pressure	-25	-13	187,1	639	161,0	1,29	4,41	1,11	144,8	1,19	4,05
pc= 45/113	-15	5	327,7	1119	282,0	1,74	5,94	1,50	188,4	1,30	7,14
return gas temp.	-10	14	420,7	1437	362,1	2,00	6,82	1,72	210,6	1,37	9,21
RGT= 32/90	-5	23	530,2	1811	456,3	2,27	7,76	1,96	233,3	1,45	11,66
liquid temp	0	32	657,1	2244	565,5	2,56	8,76	2,21	256,3	1,52	14,53
Tliq= 45/113	7,2	45	872,5	2980	750,9	3,01	10,27	2,59	290,2	1,64	19,49
[°C / °F]	-30	-22	115,4	394	99,3	0,90	3,06	0,77	128,6	1,15	2,75
cond. pressure	-25	-13	161,3	551	138,8	1,05	3,59	0,91	153,3	1,21	3,86
pc= 55/131	-15	5	286,3	978	246,4	1,41	4,82	1,22	202,8	1,35	6,89
return gas temp	-10	14	367,4	1255	316,2	1,61	5,51	1,39	227,7	1,43	8,88
RGT= 32/90	-5	23	462,2	1579	397,8	1,83	6,25	1,57	252,7	1,51	11,24
liquid temp	0	32	571,7	1952	492,0	2,06	7,03	1,77	277,8	1,60	13,98
Tliq= 55/131	7,2	45	757,0	2585	651,5	2,41	8,22	2,07	314,4	1,73	18,72