

## Model

Designation	<b>KLF7.7CND</b>	220-240V/50Hz 1~	Sales code:	<b>106H2800</b>
-------------	------------------	------------------	-------------	-----------------

## Compressor design

Oil type	Polyolester	Refrigerant(s)	<b>R290</b>
Oil viscosity	10,4cSt	Displacement	7,7cm <sup>3</sup> / 0,47cu.in
Oil quantity	174cm <sup>3</sup> / 5,9fl.oz	Compressors on pallet	100
Refr. charge - tech. limit	200g / 7,1oz		
Free gas volume comp.	1575cm <sup>3</sup> / 53,3fl.oz		
Weight	9,6kg / 21,2lbs		
Motor protection	external		
Winding resistance main	8,4Ω (at 25°C)		
Winding resistance aux	11,9Ω (at 25°C)		
Max. winding temp.	125°C / 257°F		
Max. discharge temp.	130°C / 266°F		



## General - Configurations with KLF7.7CND

	<b>Conf. 1</b>	<b>Conf. 2</b>
Motorconfiguration	CSIR	RSCR
Power supply (nominal)	220-240V/50Hz	220-240V/50Hz
Number of phases	1	1
Voltage range	198-254V	198-254V
Approvals	VDE, CCC	VDE, CCC
Starting torque	HST	LST
Note	- / -	

## Applications with KLF7.7CND

	<b>Conf. 1</b>	<b>Conf. 2</b>
Refrigerant	R290	R290
Application	LBP+MBP	LBP+MBP
System cooling	fan 3m/s	fan 3m/s
Hot gas defrost	OK	OK
Long interval pull down	OK	OK

## Electrical data - Configurations with KLF7.7CND

	<b>Conf. 1</b>	<b>Conf. 2</b>
Starting device type	relay	PTC
Run capacitor	-/-	5μF
Start capacitor	80μF	-/-
LRA (locked rotor amps / 4s/ U(N))	13,2A	13,2A
RLA (rated load amps / 1s/ U(N))	2,1A	2,1A
Cut in current (U(N))	12,3A	18,1A

## Model

Designation	<b>KLF7.7CND</b>	220-240V/50Hz 1~	Sales code:	<b>106H2800</b>
-------------	------------------	------------------	-------------	-----------------

## Compressor dimensions

<b>Housing</b>	A Height	182mm / 7,17in
	B Height	175mm / 6,89in
	C Length shell	198mm / 7,8in
	D Length w. cover	238mm / 9,37in
	E Width	160mm / 6,3in

Connectors		Suction	Discharge	Process
		X	Y	Z
Diameter	[mm]	øi 8,11-8,29	øi 6,11-6,29	øi 6,11-6,29
(i:inside, o:outside)	[in]	øi 0,32-0,33	øi 0,24-0,25	øi 0,24-0,25
Material		copper	copper	copper
Horizontal angle	±2°	35°	13°	0°
Vertical angle	±2°	30°	40°	145°
Position l/h/w	[mm]	119/73/59	117/107/66	-88/101/71
	[in]	4,7/2,9/2,3	4,6/4,2/2,6	-3,5/4/2,8
Straight tube l.	[mm]	14	14	14
	[in]	0,5	0,5	0,5

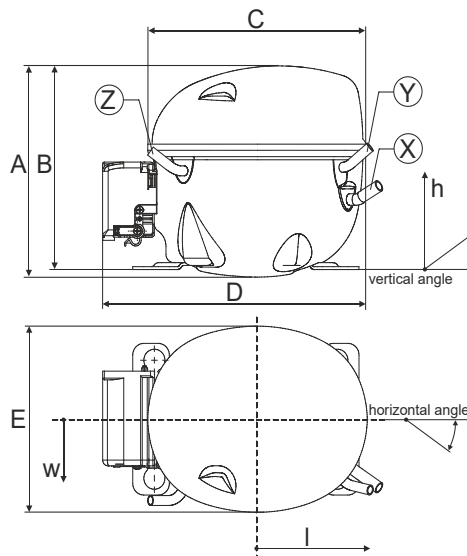

## Compressor fixation



### Bolt joint



### Snap-on

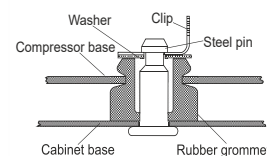

Mounting accessories	one comp.	multi pack
Bolt joint   M6   ø16mm	118-1917	118-1918
Bolt joint   ø1/4"   ø16mm	118-1946	
Bolt joint   ø1/4"   ø19mm	118-1949	
Snap-on   ø7,3   ø16mm	118-1947	118-1919

## Application notes

Provision for PE Grounding is located at the PE Stamp on the compressor

## Model

Designation	<b>KLF7.7CND</b>	<b>220-240V/50Hz</b>	<b>Conf. 1</b>	Sales code:	<b>106H2800</b>
-------------	------------------	----------------------	----------------	-------------	-----------------

## Configuration

Motorconfiguration	CSIR
Power supply (nominal)	220-240V/50Hz 1~
Refrigerant	R290
Application	LBP+MBP
Voltage range	198-254V
Starting torque	HST
Approvals	VDE CCC

## Electrical accessories / wiring diagram

CSIR



## Ambient/ machine room temperatures minimum /maximum

Ambient temperature range: 10 - 43°C / 50 - 110°F

Machine room temperature range: 10 - 48°C / 50 - 119°F

Compressor cooling: fan 3m/s

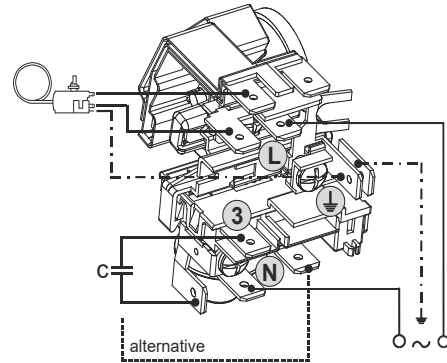

## Operation pressure range

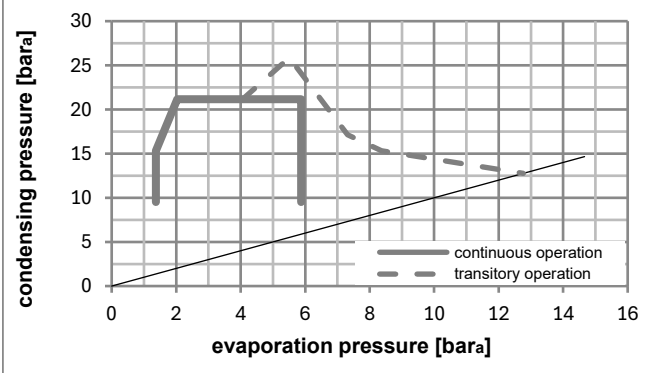
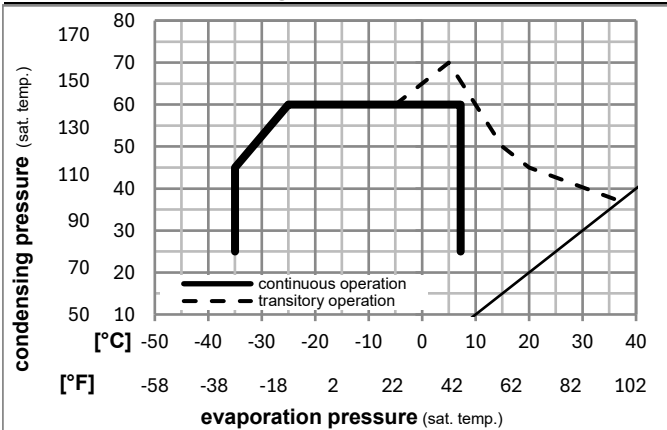

## Components

a5	current relay (T0377/L6-S1)	117U7071
c	start capacitor (80μF, 6.3mm)	117U5001
b, d	cover + clamp + screws(5VA) in bag	103N1060

## Alternative components

b, d	100x cover + clamp + screws(5VA)	103N2060
b, d	cover + clamp + screws(5VA-compl.)	103N0600

## Model

Designation **KLF7.7CND** **220-240V/50Hz** Conf. 1 Sales code: **106H2800**

## Optimization + standard conditions

R290, 220V/50Hz, CSIR, fan 3m/s, VDE, CCC

	Evaporating pressure (saturation temperature)				Condensing pressure (saturation temperature)			Return gas temp.	Liquid temp.	Cooling capacity	COP	EER	Power consumption			Ref. mass flow
	pe	pc	RGT	Tliq	[W]	[Btu/h]	[kcal/h]						P1	I	m	
	[°C]	[°F]	[°C]	[°F]	[W]	[Btu/h]	[kcal/h]	[W/W]	[Btu/Wh]	[kcal/Wh]	[W]	[A]	[kg/h]			
ASHRAE LBP	-23	54	32	32	384,5	1313	330,9	1,52	5,18	1,30	253,7	1,68	3,89			
	-10	130	90	90												
cecomaf LBP	-25	55	32	55	287,6	982	247,5	1,18	4,02	1,01	244,6	1,65	3,58			
	-13	131	90	131												
EN12900 LBP	-35	40	20	40	222,6	760	191,6	1,20	4,12	1,04	184,8	1,49	2,54			
	-31	104	68	104												
ASHRAE MBP	-7	54	35	46	687,7	2349	591,9	2,00	6,84	1,72	343,3	1,99	7,85			
	20	130	95	115												
cecomaf MBP	-10	55	32	55	547,3	1869	471,0	1,67	5,71	1,44	327,5	1,93	6,92			
	14	131	90	131												
EN12900 MBP	-10	45	20	45	608,6	2079	523,8	2,03	6,93	1,75	299,9	1,83	7,47			
	14	113	68	113												

## Performance tables

R290, 220V/50Hz, CSIR, fan 3m/s, VDE, CCC

	pe		Cooling capacity			COP	EER	P1	I	m	
	[°C]	[°F]	[W]	[Btu/h]	[kcal/h]	[W/W]	[Btu/Wh]	[kcal/Wh]	[W]	[A]	[kg/h]
[°C / °F]	-35	-31	210,1	717	180,8	1,11	3,79	0,96	189,1	1,50	2,35
cond. pressure	-25	-13	342,0	1168	294,3	1,46	4,98	1,26	234,3	1,62	3,86
pc= 45/113	-15	5	523,0	1786	450,1	1,88	6,42	1,62	278,4	1,76	5,95
return gas temp.	-10	14	633,6	2164	545,3	2,11	7,22	1,82	299,9	1,83	7,25
RGT= 32/90	-5	23	758,6	2591	652,8	2,36	8,07	2,03	321,1	1,91	8,73
liquid temp	0	32	898,6	3069	773,3	2,63	8,97	2,26	342,0	1,99	10,42
Tliq= 45/113	7,2	45	1127,9	3852	970,7	3,04	10,37	2,61	371,3	2,10	13,25
[°C / °F]	-35	-31	170,7	583	146,9	0,92	3,13	0,79	186,0	1,49	2,11
cond. pressure	-25	-13	287,6	982	247,5	1,18	4,02	1,01	244,6	1,65	3,58
pc= 55/131	-15	5	448,6	1532	386,0	1,49	5,10	1,28	300,5	1,84	5,64
return gas temp	-10	14	547,3	1869	471,0	1,67	5,71	1,44	327,5	1,93	6,92
RGT= 32/90	-5	23	659,1	2251	567,2	1,86	6,36	1,60	353,6	2,03	8,40
liquid temp	0	32	784,6	2680	675,3	2,07	7,07	1,78	379,1	2,13	10,08
Tliq= 55/131	7,2	45	991,0	3385	852,9	2,39	8,17	2,06	414,5	2,27	12,91

## Model

Designation	<b>KLF7.7CND</b>	<b>220-240V/50Hz</b>	<b>Conf. 2</b>	Sales code:	<b>106H2800</b>
-------------	------------------	----------------------	----------------	-------------	-----------------

## Configuration

Motorconfiguration	RSCR
Power supply (nominal)	220-240V/50Hz 1~
Refrigerant	R290
Application	LBP+MBP
Voltage range	198-254V
Starting torque	LST
Approvals	VDE CCC

## Electrical accessories / wiring diagram

RSCR

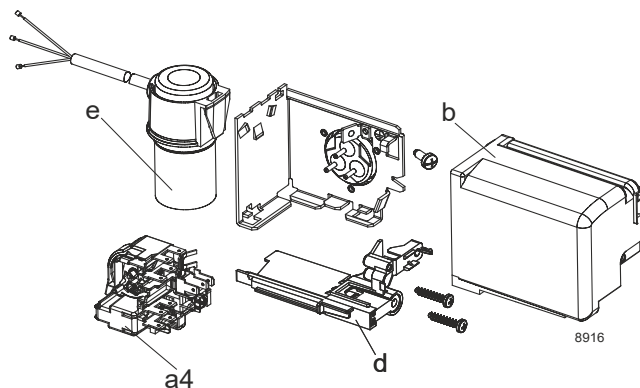

## Ambient/ machine room temperatures minimum /maximum

Ambient temperature range: 10 - 43°C / 50 - 110°F

Machine room temperature range: 10 - 48°C / 50 - 119°F

Compressor cooling: fan 3m/s

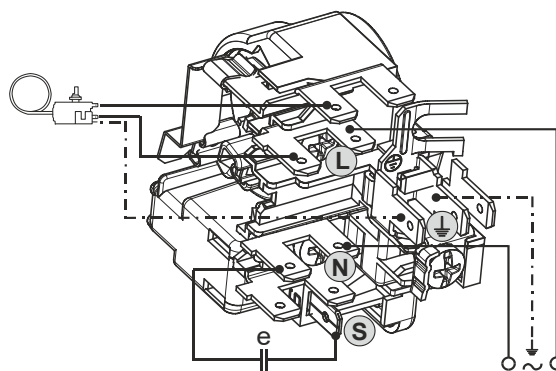

## Operation pressure range

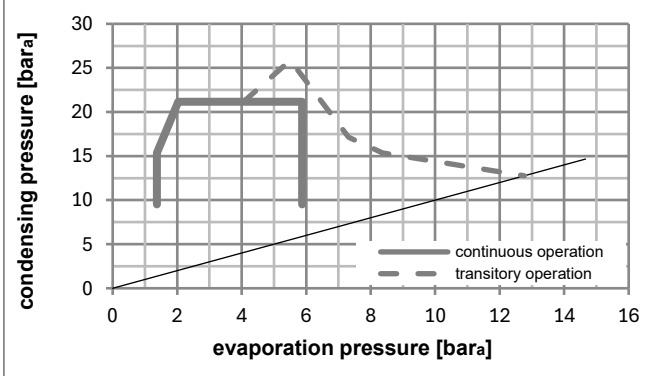
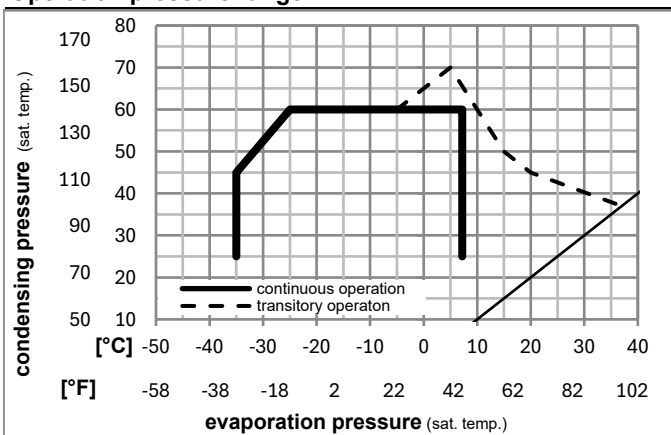

## Components

a4	DAS1 (PTC,6.3mm, T0377/L6 - S1)	103N0250
e	run capacitor (5μF, 6.3mm)	117-7191
b, d	cover + clamp + screws(5VA) in bag	103N1060

## Alternative components

a4	ZAS1 (PTC,4.8mm, T0377/L6 - S1)	103N0252
e	run capacitor (5μF, 4.8mm)	117-7190

b, d	100x cover + clamp + screws(5VA)	103N2060
b, d	cover + clamp + screws(5VA-compl.)	103N0600

## Model

Designation **KLF7.7CND** **220-240V/50Hz** Conf. 2 Sales code: **106H2800**

## Optimization + standard conditions

R290, 220V/50Hz, RSCR, fan 3m/s, VDE, CCC

	Evaporating pressure (saturation temperature)				Cooling capacity			COP	EER			Power consumption			ASHRAE LBP
	pe	pc	RGT	Tliq	[W]	[Btu/h]	[kcal/h]		[W/W]	[Btu/Wh]	[kcal/Wh]	P1	I	m	
	[°C]	[°C]	[°C]	[°C]							[W]	[A]	[kg/h]		
	-23	54	32	32	387,4	1323	333,4	1,60	5,46	1,38	242,2	1,36	3,92	ASHRAE LBP	
	[°F]														
	-10	130	90	90											
	-25	55	32	55	289,8	990	249,4	1,24	4,24	1,07	233,6	1,33	3,61	cecomaf LBP	
	[°F]														
	-13	131	90	131											
	-35	40	20	40	224,1	765	192,9	1,27	4,32	1,09	177,0	1,13	2,56	EN12900 LBP	
	[°F]														
	-31	104	68	104											
	-7	54	35	46	693,9	2370	597,2	2,12	7,26	1,83	326,6	1,69	7,92	ASHRAE MBP	
	[°F]														
	20	130	95	115											
	-10	55	32	55	552,0	1885	475,1	1,77	6,05	1,52	311,7	1,63	6,98	cecomaf MBP	
	[°F]														
	14	131	90	131											
	-10	45	20	45	613,6	2096	528,1	2,15	7,33	1,85	285,9	1,53	7,53	EN12900 MBP	
	[°F]														
	14	113	68	113											

## Performance tables

R290, 220V/50Hz, RSCR, fan 3m/s, VDE, CCC

	pe		Cooling capacity			COP	EER		P1	I	m
	[°C]	[°F]	[W]	[Btu/h]	[kcal/h]		[W/W]	[Btu/Wh]			
[°C / °F]	-35	-31	211,5	722	182,0	1,17	3,99	1,00	181,2	1,14	2,37
cond. pressure	-25	-13	344,5	1177	296,5	1,54	5,25	1,32	223,9	1,29	3,89
pc= 45/113	-15	5	527,1	1800	453,7	1,98	6,78	1,71	265,6	1,44	6,00
return gas temp.	-10	14	638,8	2182	549,8	2,23	7,63	1,92	285,9	1,53	7,31
RGT= 32/90	-5	23	765,1	2613	658,4	2,50	8,54	2,15	305,9	1,61	8,81
liquid temp	0	32	906,6	3096	780,2	2,79	9,51	2,40	325,4	1,69	10,52
Tliq= 45/113	7,2	45	1138,6	3888	979,9	3,23	11,02	2,78	352,8	1,80	13,38
[°C / °F]	-35	-31	171,9	587	147,9	0,96	3,30	0,83	178,1	1,14	2,13
cond. pressure	-25	-13	289,8	990	249,4	1,24	4,24	1,07	233,6	1,33	3,61
pc= 55/131	-15	5	452,3	1545	389,2	1,58	5,39	1,36	286,4	1,53	5,69
return gas temp	-10	14	552,0	1885	475,1	1,77	6,05	1,52	311,7	1,63	6,98
RGT= 32/90	-5	23	665,1	2271	572,4	1,98	6,75	1,70	336,3	1,73	8,47
liquid temp	0	32	792,2	2706	681,8	2,20	7,51	1,89	360,0	1,83	10,18
Tliq= 55/131	7,2	45	1001,3	3419	861,7	2,55	8,71	2,19	392,8	1,97	13,04