

Model

Designation	KLF7.7CND	220-240V/50Hz 1~	Sales code:	106H2805
-------------	------------------	------------------	-------------	-----------------

Compressor design

Oil type	Polyolester	Refrigerant(s)	R290
Oil viscosity	9,7cST	Displacement	7,7cm ³ / 0,47cu.in
Oil quantity	170cm ³ / 5,7fl.oz	Compressors on pallet	100
Refr. charge - tech. limit	200g / 7,1oz		
Free gas volume comp.	1575cm ³ / 53,3fl.oz		
Weight	9,6kg / 21,2lbs		
Motor protection	external		
Winding resistance main	8,4Ω (at 25°C)		
Winding resistance aux	11,9Ω (at 25°C)		
Max. winding temp.	125°C / 257°F		
Max. discharge temp.	130°C / 266°F		



General - Configurations with KLF7.7CND

	Conf. 1	Conf. 2
Motorconfiguration	CSIR	RSCR
Power supply (nominal)	220-240V/50Hz	220-240V/50Hz
Number of phases	1	1
Voltage range	198-254V	198-254V
Approvals	VDE, CCC	VDE, CCC
Starting torque	HST	LST
Note	Housing with dip-tray fixture (omega bracket).	

Applications with KLF7.7CND

	Conf. 1	Conf. 2
Refrigerant	R290	R290
Application	LBP+MBP	LBP+MBP
System cooling	fan 3m/s	fan 3m/s
Hot gas defrost	OK	OK
Long interval pull down	OK	OK

Electrical data - Configurations with KLF7.7CND

	Conf. 1	Conf. 2
Starting device type	relay	PTC
Run capacitor	-/-	5μF
Start capacitor	80μF	-/-
LRA (locked rotor amps / 4s)	12,3A	11A
RLA (rated load amps / 1s)	2,1A	2,1A
Cut in current	12,3A	18,1A

Model

Designation

KLF7.7CND

220-240V/50Hz 1~

Sales code:

106H2805

Compressor dimensions

Housing	A Height	182mm / 7,17in
	B Height	175mm / 6,89in
	C Length shell	198mm / 7,8in
	D Length w. cover	238mm / 9,37in
	E Width	160mm / 6,3in

Connectors		Suction	Discharge	Process
		X	Y	Z
Diameter	[mm]	øi 8,11-8,29	øi 6,11-6,29	øi 6,11-6,29
	(i:inside, o:outside) [in]	øi 0,32-0,33	øi 0,24-0,25	øi 0,24-0,25
Material		copper	copper	copper
Horizontal angle	±2°	35°	13°	0°
Vertical angle	±2°	30°	40°	145°
Position l/h/w	[mm]	120/72/57	112/106/81	-97/94/72
	[in]	4,7/2,8/2,2	4,4/4,2/3,2	-3,8/3,7/2,8
Straight tube l.	[mm]	14	14	14
	[in]	0,5	0,5	0,5

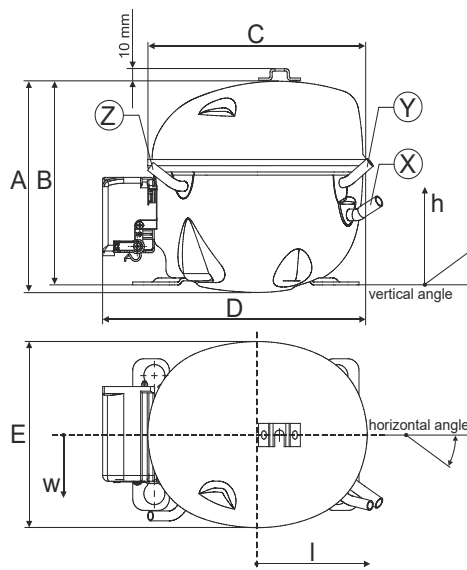

Compressor fixation

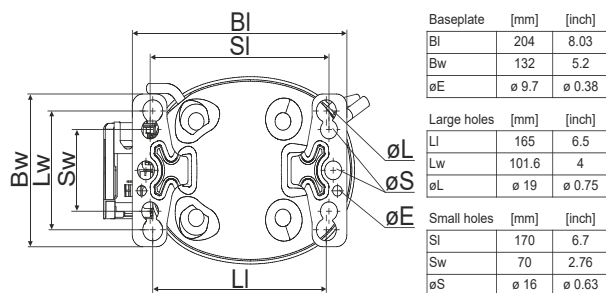

Bolt joint

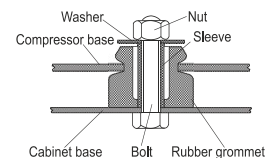

Snap-on

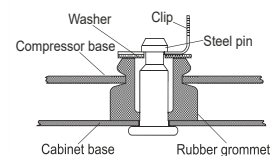

Mounting accessories	one comp.	multi pack
Bolt joint M6 ø16mm	118-1917	118-1918
Bolt joint ø1/4" ø16mm	118-1946	
Bolt joint ø1/4" ø19mm	118-1949	
Snap-on ø7,3 ø16mm	118-1947	118-1919

Application notes

Housing with dip-tray fixture (omega bracket).

Provision for PE Grounding is located at the PE Stamp on the compressor

Model

Designation	KLF7.7CND	220-240V/50Hz	Conf. 1	Sales code:	106H2805
-------------	------------------	----------------------	---------	-------------	-----------------

Configuration

Motorconfiguration	CSIR
Power supply (nominal)	220-240V/50Hz 1~
Refrigerant	R290
Application	LBP+MBP
Voltage range	198-254V
Starting torque	HST
Approvals	VDE
	CCC

Electrical accessories / wiring diagram

CSIR

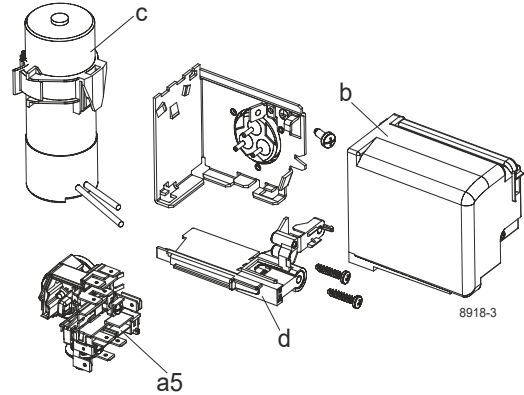

Ambient/ machine room temperatures minimum /maximum

Ambient temperature range: 10 - 43°C / 50 - 110°F

Machine room temperature range: 10 - 48°C / 50 - 119°F

Compressor cooling: fan 3m/s

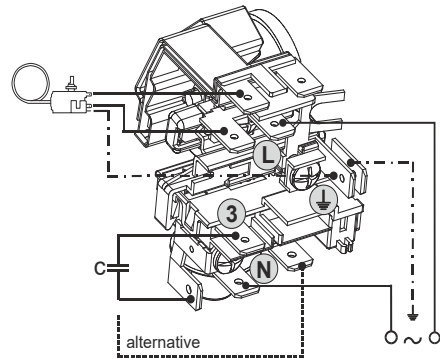

Operation pressure range

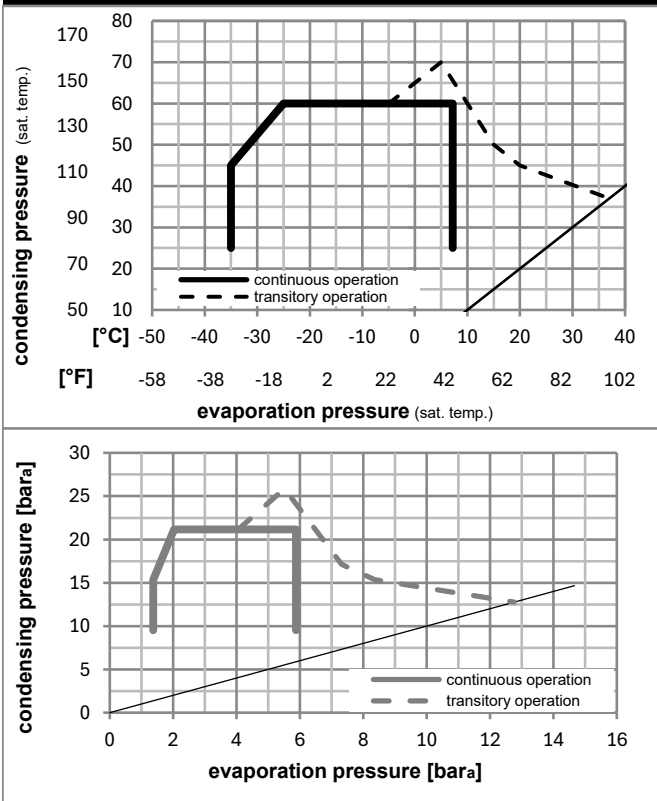

Components

a5	current relay (T0377/L6-S1)	117U7071
c	start capacitor (80µF, 6.3mm)	117U5001
b, d	cover + clamp + screws(5VA) in bag	103N1060

Alternative components

b, d	cover + clamp + screws(5VA-compl.)	103N0600
------	------------------------------------	----------

Model

Designation	KLF7.7CND	220-240V/50Hz	Conf. 1	Sales code:	106H2805
-------------	------------------	----------------------	----------------	-------------	-----------------

Optimization + standard conditions

R290, 220V/50Hz, CSIR, fan 3m/s, VDE, CCC

	Evaporating pressure (saturation temperature)				Cooling capacity			COP	EER	P1	Power consumption		ASHRAE LBP	
	pe	pc	RGT	Tliq	[W]	[Btu/h]	[kcal/h]				I	m		
	[°C]	[°F]	[°C]	[°F]	[W]	[Btu/h]	[kcal/h]	[W/W]	[Btu/Wh]	[kcal/Wh]	[W]	[A]	[kg/h]	
	-23	54	32	32	384,5	1313	330,9	1,52	5,18	1,30	253,7	1,68	3,89	ASHRAE LBP
	-10	130	90	90										
	-25	55	32	55	287,6	982	247,5	1,18	4,02	1,01	244,6	1,65	3,58	cecomaf LBP
	-13	131	90	131										
	-35	40	20	40	222,6	760	191,6	1,20	4,12	1,04	184,8	1,49	2,54	EN12900 LBP
	-31	104	68	104										
	-7	54	35	46	687,7	2349	591,9	2,00	6,84	1,72	343,3	1,99	7,85	ASHRAE MBP
	20	130	95	115										
	-10	55	32	55	547,3	1869	471,0	1,67	5,71	1,44	327,5	1,93	6,92	cecomaf MBP
	14	131	90	131										
	-10	45	20	45	608,6	2079	523,8	2,03	6,93	1,75	299,9	1,83	7,47	EN12900 MBP
	14	113	68	113										

Performance tables

R290, 220V/50Hz, CSIR, fan 3m/s, VDE, CCC

	pe		Cooling capacity			COP	EER		P1	I	m
	[°C]	[°F]	[W]	[Btu/h]	[kcal/h]		[Btu/Wh]	[kcal/Wh]			
[°C / °F]	-35	-31	210,1	717	180,8	1,11	3,79	0,96	189,1	1,50	2,35
cond. pressure	-25	-13	342,0	1168	294,3	1,46	4,98	1,26	234,3	1,62	3,86
pc= 45/113	-15	5	523,0	1786	450,1	1,88	6,42	1,62	278,4	1,76	5,95
return gas temp.	-10	14	633,6	2164	545,3	2,11	7,22	1,82	299,9	1,83	7,25
RGT= 32/90	-5	23	758,6	2591	652,8	2,36	8,07	2,03	321,1	1,91	8,73
liquid temp	0	32	898,6	3069	773,3	2,63	8,97	2,26	342,0	1,99	10,42
Tliq= 45/113	7,2	45	1127,9	3852	970,7	3,04	10,37	2,61	371,3	2,10	13,25
[°C / °F]	-35	-31	170,7	583	146,9	0,92	3,13	0,79	186,0	1,49	2,11
cond. pressure	-25	-13	287,6	982	247,5	1,18	4,02	1,01	244,6	1,65	3,58
pc= 55/131	-15	5	448,6	1532	386,0	1,49	5,10	1,28	300,5	1,84	5,64
return gas temp	-10	14	547,3	1869	471,0	1,67	5,71	1,44	327,5	1,93	6,92
RGT= 32/90	-5	23	659,1	2251	567,2	1,86	6,36	1,60	353,6	2,03	8,40
liquid temp	0	32	784,6	2680	675,3	2,07	7,07	1,78	379,1	2,13	10,08
Tliq= 55/131	7,2	45	991,0	3385	852,9	2,39	8,17	2,06	414,5	2,27	12,91

Model

Designation	KLF7.7CND	220-240V/50Hz	Conf. 2	Sales code:	106H2805
-------------	------------------	----------------------	----------------	-------------	-----------------

Configuration

Motorconfiguration	RSCR
Power supply (nominal)	220-240V/50Hz 1~
Refrigerant	R290
Application	LBP+MBP
Voltage range	198-254V
Starting torque	LST
Approvals	VDE CCC

Electrical accessories / wiring diagram

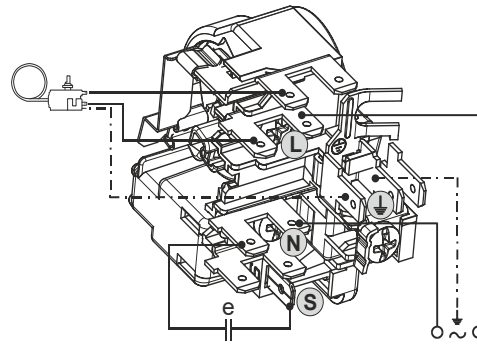
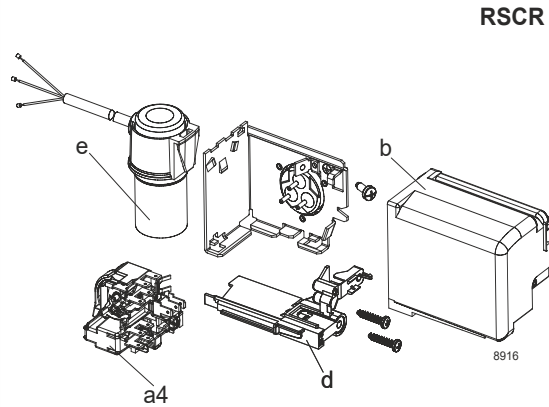

Ambient/ machine room temperatures minimum /maximum

Ambient temperature range: 10 - 43°C / 50 - 110°F

Machine room temperature range: 10 - 48°C / 50 - 119°F

Compressor cooling: fan 3m/s

Operation pressure range

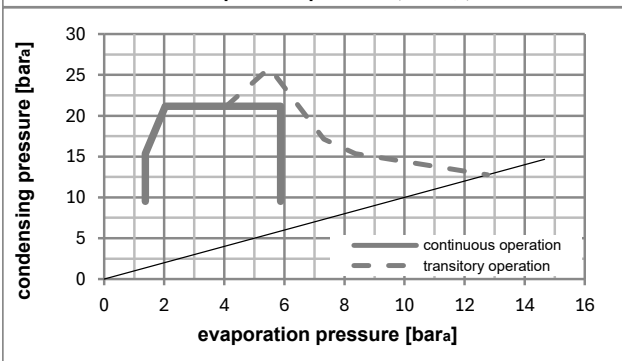
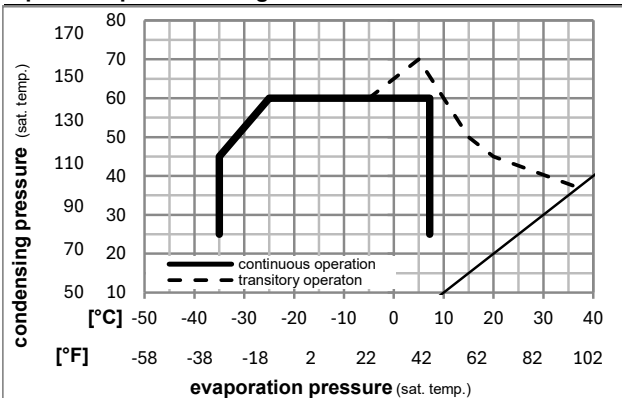

Components

a4	DAS1 (PTC,6.3mm, T0377/L6 - S1)	103N0250
e	run capacitor (5μF, 6.3mm)	117-7191
b, d	cover + clamp + screws(5VA) in bag	103N1060

Alternative components

a4	ZAS1 (PTC,4.8mm, T0377/L6 - S1)	103N0252
e	run capacitor (5μF, 4.8mm)	117-7190

b, d	cover + clamp + screws(5VA-compl.)	103N0600
------	------------------------------------	----------

Model

Designation	KLF7.7CND	220-240V/50Hz	Conf. 2	Sales code:	106H2805
-------------	------------------	----------------------	----------------	-------------	-----------------

Optimization + standard conditions

R290, 220V/50Hz, RSCR, fan 3m/s, VDE, CCC

	pe	pc	RGT	Tliq	Cooling capacity	COP	EER	P1	I	Ref. mass flow	
	[°C]	[°C]	[°C]	[°C]	[W]	[W/W]	[Btu/Wh]	[W]	[A]	[kg/h]	
	[°F]	[°F]	[°F]	[°F]	[Btu/h]	[kcal/h]	[kcal/Wh]	[W]	[A]	[kg/h]	
ASHRAE LBP	-23	54	32	32	387,4	1,60	5,46	242,2	1,36	3,92	
	-10	130	90	90			1,38				
cecomaf LBP	-25	55	32	55	289,8	1,24	4,24	233,6	1,33	3,61	
	-13	131	90	131			1,07				
EN12900 LBP	-35	40	20	40	224,1	1,27	4,32	177,0	1,13	2,56	
	-31	104	68	104			1,09				
ASHRAE MBP	-7	54	35	46	693,9	2,12	7,26	326,6	1,69	7,92	
	20	130	95	115			1,83				
cecomaf MBP	-10	55	32	55	552,0	1,77	6,05	311,7	1,63	6,98	
	14	131	90	131			1,52				
EN12900 MBP	-10	45	20	45	613,6	2,15	7,33	285,9	1,53	7,53	
	14	113	68	113			1,85				

Performance tables

R290, 220V/50Hz, RSCR, fan 3m/s, VDE, CCC

	pe	Cooling capacity			COP	EER	P1	I	m		
	[°C]	[°F]	[W]	[Btu/h]	[kcal/h]	[W/W]	[Btu/Wh]	[kcal/Wh]	[W]	[A]	[kg/h]
[°C / °F]	-35	-31	211,5	722	182,0	1,17	3,99	1,00	181,2	1,14	2,37
cond. pressure	-25	-13	344,5	1177	296,5	1,54	5,25	1,32	223,9	1,29	3,89
pc= 45/113	-15	5	527,1	1800	453,7	1,98	6,78	1,71	265,6	1,44	6,00
return gas temp.	-10	14	638,8	2182	549,8	2,23	7,63	1,92	285,9	1,53	7,31
RGT= 32/90	-5	23	765,1	2613	658,4	2,50	8,54	2,15	305,9	1,61	8,81
liquid temp	0	32	906,6	3096	780,2	2,79	9,51	2,40	325,4	1,69	10,52
Tliq= 45/113	7,2	45	1138,6	3888	979,9	3,23	11,02	2,78	352,8	1,80	13,38
[°C / °F]	-35	-31	171,9	587	147,9	0,96	3,30	0,83	178,1	1,14	2,13
cond. pressure	-25	-13	289,8	990	249,4	1,24	4,24	1,07	233,6	1,33	3,61
pc= 55/131	-15	5	452,3	1545	389,2	1,58	5,39	1,36	286,4	1,53	5,69
return gas temp	-10	14	552,0	1885	475,1	1,77	6,05	1,52	311,7	1,63	6,98
RGT= 32/90	-5	23	665,1	2271	572,4	1,98	6,75	1,70	336,3	1,73	8,47
liquid temp	0	32	792,2	2706	681,8	2,20	7,51	1,89	360,0	1,83	10,18
Tliq= 55/131	7,2	45	1001,3	3419	861,7	2,55	8,71	2,19	392,8	1,97	13,04