

Model

Designation	KLF7.7CNDS	220-240V/50Hz 1~	Sales code:	106h2803
-------------	-------------------	------------------	-------------	-----------------

Compressor design

Oil type	Polyolester	Refrigerant(s)	R290
Oil viscosity	9,7cST	Displacement	7,7cm ³ / 0,47cu.in
Oil quantity	170cm ³ / 5,7fl.oz	Compressors on pallet	100
Refr. charge - tech. limit	200g / 7,1oz		
Free gas volume comp.	1575cm ³ / 53,3fl.oz		
Weight	9,6kg / 21,2lbs		
Motor protection	external		
Winding resistance main	8,4Ω (at 25°C)		
Winding resistance aux	11,9Ω (at 25°C)		
Max. winding temp.	125°C / 257°F		
Max. discharge temp.	130°C / 266°F		
Additional note	Very good robustness against liquid intake. Ice-cube maker optimization - indirect suction intake.		



General - Configurations with KLF7.7CNDS

	Conf. 1
Motorconfiguration	CSIR
Power supply (nominal)	220-240V/50Hz
Number of phases	1
Voltage range	198-254V
Approvals	VDE, CCC
Starting torque	HST
Note	- / -

Applications with KLF7.7CNDS

	Conf. 1
Refrigerant	R290
Application	LBP+MBP
System cooling	fan 3m/s
Hot gas defrost	OK
Long interval pull down	OK

Electrical data - Configurations with KLF7.7CNDS

	Conf. 1
Starting device type	relay
Run capacitor	-/-
Start capacitor	80μF
LRA (locked rotor amps / 4s)	12,3A
RLA (rated load amps / 1s)	2,1A
Cut in current	12,3A

Model

Designation

KLF7.7CNDS

220-240V/50Hz 1~

Sales code:

106h2803

Compressor dimensions

Housing	A Height	182mm / 7,17in
	B Height	175mm / 6,89in
	C Length shell	198mm / 7,8in
	D Length w. cover	238mm / 9,37in
	E Width	160mm / 6,3in

Connectors		Suction	Discharge	Process
		X	Y	Z
Diameter	[mm]	øi 8,11-8,29	øi 6,11-6,29	øi 6,11-6,29
	(i:inside, o:outside) [in]	øi 0,32-0,33	øi 0,24-0,25	øi 0,24-0,25
Material		copper	copper	copper
Horizontal angle	±2°	35°	13°	0°
Vertical angle	±2°	30°	40°	145°
Position l/h/w	[mm]	120/72/57	112/106/81	-97/94/72
	[in]	4,7/2,8/2,2	4,4/4,2/3,2	-3,8/3,7/2,8
Straight tube l.	[mm]	14	14	14
	[in]	0,5	0,5	0,5

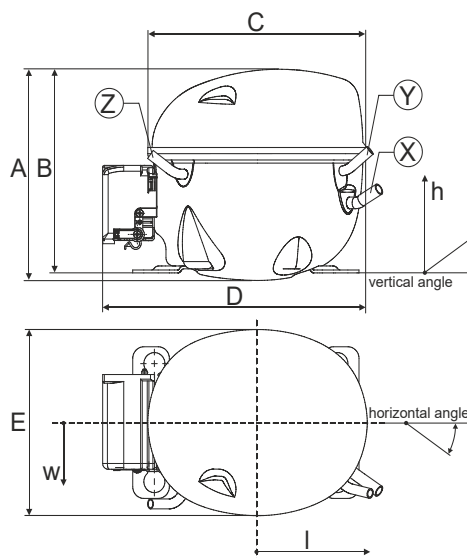

Compressor fixation

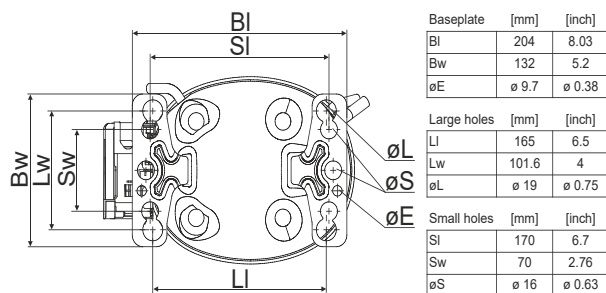

Bolt joint

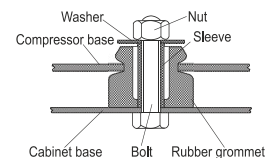

Snap-on

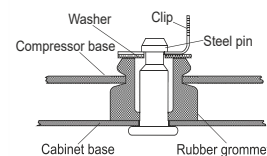

Mounting accessories

Mounting accessories	one comp.	multi pack
Bolt joint M6 ø16mm	118-1917	118-1918
Bolt joint ø1/4" ø16mm	118-1946	
Bolt joint ø1/4" ø19mm	118-1949	
Snap-on ø7,3 ø16mm	118-1947	118-1919

Application notes

Provision for PE Grounding is located at the PE Stamp on the compressor

Model

Designation	KLF7.7CNDS	220-240V/50Hz	Conf. 1	Sales code:	106h2803
-------------	-------------------	----------------------	---------	-------------	-----------------

Configuration

Motorconfiguration	CSIR
Power supply (nominal)	220-240V/50Hz 1~
Refrigerant	R290
Application	LBP+MBP
Voltage range	198-254V
Starting torque	HST
Approvals	VDE
	CCC

Electrical accessories / wiring diagram

CSIR

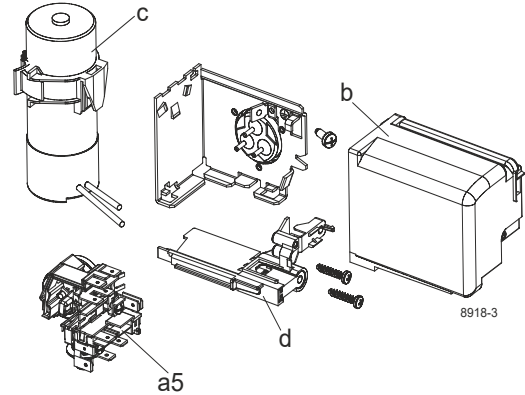

Ambient/ machine room temperatures minimum /maximum

Ambient temperature range: 10 - 43°C / 50 - 110°F

Machine room temperature range: 10 - 48°C / 50 - 119°F

Compressor cooling: fan 3m/s

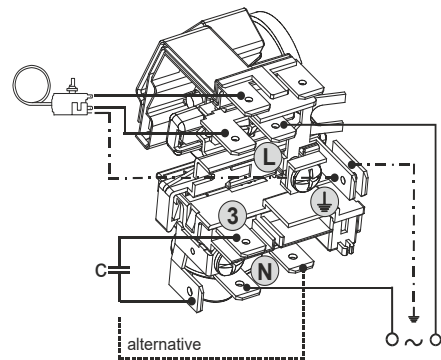

Operation pressure range

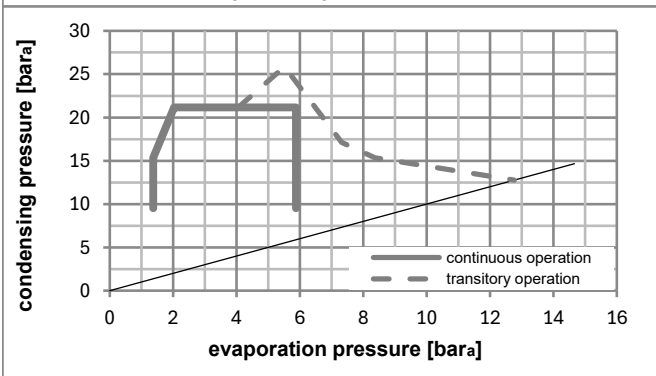
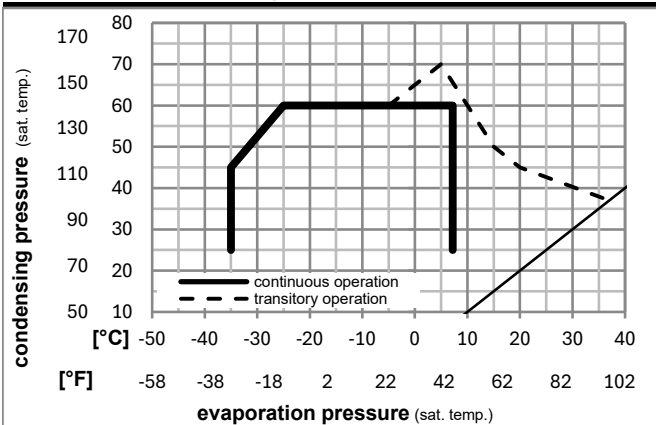

Components

a5	current relay (T0377/L6-S1)	117U7071
c	start capacitor (80µF, 6.3mm)	117U5001
b, d	cover + clamp + screws(5VA) in bag	103N1060

Alternative components

b, d	cover + clamp + screws(5VA-compl.)	103N0600
------	------------------------------------	----------

Model

Designation	KLF7.7CNDS	220-240V/50Hz	Conf. 1	Sales code:	106h2803
-------------	-------------------	----------------------	----------------	-------------	-----------------

Optimization + standard conditions

R290, 220V/50Hz, CSIR, fan 3m/s, VDE, CCC

	Evaporating pressure (saturation temperature)				Cooling capacity			COP	EER	P1	Power consumption		ASHRAE LBP	
	pe	pc	RGT	Tliq	[W]	[Btu/h]	[kcal/h]				I	m		
	[°C]	[°F]	[°C]	[°F]	[W]	[Btu/h]	[kcal/h]	[W/W]	[Btu/Wh]	[kcal/Wh]	[W]	[A]	[kg/h]	
	-23	54	32	32	371,0	1267	319,3	1,48	5,05	1,27	251,0	1,66	3,76	ASHRAE LBP
	-10	130	90	90										
	-25	55	32	55	277,5	948	238,8	1,15	3,92	0,99	242,0	1,64	3,46	cecomaf LBP
	-13	131	90	131										
	-35	40	20	40	214,8	734	184,8	1,17	4,01	1,01	182,8	1,47	2,45	EN12900 LBP
	-31	104	68	104										
	-7	54	35	46	663,5	2266	571,0	1,95	6,67	1,68	339,6	1,97	7,57	ASHRAE MBP
	20	130	95	115										
	-10	55	32	55	528,0	1803	454,4	1,63	5,57	1,40	324,0	1,91	6,68	cecomaf MBP
	14	131	90	131										
	-10	45	20	45	587,2	2005	505,4	1,98	6,76	1,70	296,7	1,81	7,21	EN12900 MBP
	14	113	68	113										

Performance tables

R290, 220V/50Hz, CSIR, fan 3m/s, VDE, CCC

	pe		Cooling capacity			COP	EER		P1	I	m
	[°C]	[°F]	[W]	[Btu/h]	[kcal/h]		[Btu/Wh]	[kcal/Wh]			
[°C / °F]	-35	-31	202,7	692	174,4	1,08	3,70	0,93	187,1	1,48	2,27
cond. pressure	-25	-13	330,0	1127	284,0	1,42	4,86	1,22	231,9	1,60	3,72
pc= 45/113	-15	5	504,6	1723	434,2	1,83	6,26	1,58	275,4	1,74	5,74
return gas temp.	-10	14	611,3	2088	526,1	2,06	7,04	1,77	296,7	1,81	6,99
RGT= 32/90	-5	23	731,9	2499	629,8	2,30	7,87	1,98	317,7	1,89	8,43
liquid temp	0	32	866,9	2961	746,1	2,56	8,75	2,20	338,4	1,97	10,06
Tliq= 45/113	7,2	45	1088,2	3716	936,5	2,96	10,11	2,55	367,4	2,08	12,78
[°C / °F]	-35	-31	164,7	563	141,8	0,89	3,06	0,77	184,1	1,48	2,04
cond. pressure	-25	-13	277,5	948	238,8	1,15	3,92	0,99	242,0	1,64	3,46
pc= 55/131	-15	5	432,8	1478	372,4	1,46	4,97	1,25	297,4	1,82	5,44
return gas temp	-10	14	528,0	1803	454,4	1,63	5,57	1,40	324,0	1,91	6,68
RGT= 32/90	-5	23	635,9	2172	547,2	1,82	6,21	1,56	349,9	2,01	8,10
liquid temp	0	32	757,0	2585	651,5	2,02	6,89	1,74	375,1	2,11	9,72
Tliq= 55/131	7,2	45	956,1	3265	822,9	2,33	7,96	2,01	410,1	2,25	12,46