

Model

Designation	KLF7.7CNH	115-127V/60Hz 1~	Sales code:	106H3802
-------------	------------------	------------------	-------------	-----------------

Compressor design

Oil type	Polyolester	Refrigerant(s)	R290
Oil viscosity	19,2cSt	Displacement	7,7cm ³ / 0,47cu.in
Oil quantity	162cm ³ / 5,5fl.oz	Compressors on pallet	100
Refr. charge - tech. limit	200g / 7,1oz		
Free gas volume comp.	1575cm ³ / 53,3fl.oz		
Weight	9,7kg / 21,4lbs		
Motor protection	external		
Winding resistance main	1,4Ω (at 25°C)		
Winding resistance aux	5,9Ω (at 25°C)		
Max. winding temp.	125°C / 257°F		
Max. discharge temp.	130°C / 266°F		



General - Configurations with KLF7.7CNH

	Conf. 1	Conf. 2
Motorconfiguration	CSIR	RSCR
Power supply (nominal)	115-127V/60Hz	115-127V/60Hz
Number of phases	1	1
Voltage range	95-140V	95-140V
Approvals	UL	UL
Starting torque	HST	LST
Note	- / -	

Applications with KLF7.7CNH

	Conf. 1	Conf. 2
Refrigerant	R290	R290
Application	LBP+MBP	LBP+MBP
System cooling	fan 3m/s	fan 3m/s
Hot gas defrost	OK	OK
Long interval pull down	OK	OK

Electrical data - Configurations with KLF7.7CNH

	Conf. 1	Conf. 2
Starting device type	relay	PTC
Run capacitor	-/-	15μF
Start capacitor	240μF	-/-
LRA (locked rotor amps / 4s/ U(N))	35,6A	35,6A
RLA (rated load amps / 1s/ U(N))	4,9A	4,9A
Cut in current (U(N))		

Model

Designation	KLF7.7CNH	115-127V/60Hz 1~	Sales code:	106H3802
-------------	------------------	------------------	-------------	-----------------

Compressor dimensions

Housing	A Height	182mm / 7,17in
	B Height	175mm / 6,89in
	C Length shell	198mm / 7,8in
	D Length w. cover	238mm / 9,37in
	E Width	160mm / 6,3in

Connectors		Suction	Discharge	Process
		X	Y	Z
Diameter	[mm]	øi 8,11-8,29	øi 6,41-6,59	øi 6,41-6,59
(i:inside, o:outside)	[in]	øi 0,32-0,33	øi 0,25-0,26	øi 0,25-0,26
Material		copper	copper	copper
Horizontal angle	±2°	35°	13°	0°
Vertical angle	±2°	30°	40°	145°
Position l/h/w	[mm]	119/73/59	117/107/66	-88/101/71
	[in]	4,7/2,9/2,3	4,6/4,2/2,6	-3,5/4/2,8
Straight tube l.	[mm]	14	14	14
	[in]	0,5	0,5	0,5

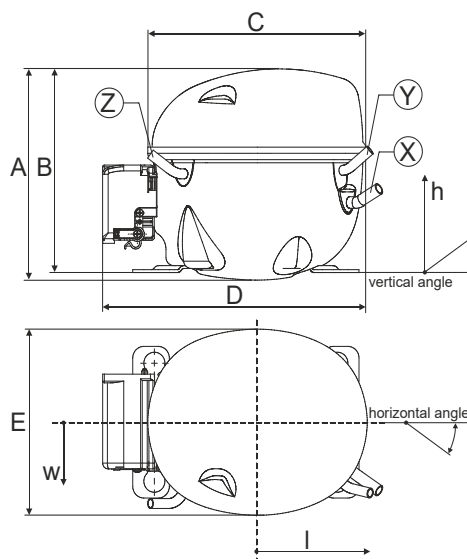

Compressor fixation

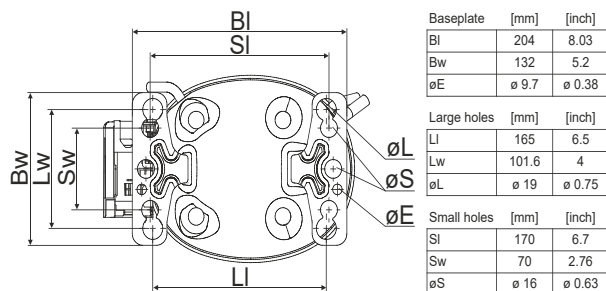

Bolt joint

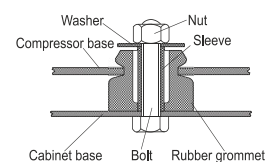

Snap-on

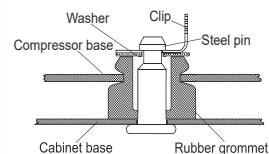

Mounting accessories	one comp.	multi pack
Bolt joint M6 ø16mm	118-1917	118-1918
Bolt joint ø1/4" ø16mm	118-1946	
Bolt joint ø1/4" ø19mm	118-1949	
Snap-on ø7,3 ø16mm	118-1947	118-1919

Application notes

Provision for PE Grounding is located at the PE Stamp on the compressor

Compressor comes on a wooden pallet

Model

Designation	KLF7.7CNH	115-127V/60Hz	Conf. 1	Sales code:	106H3802
-------------	------------------	----------------------	----------------	-------------	-----------------

Configuration

Motorconfiguration	CSIR
Power supply (nominal)	115-127V/60Hz 1~
Refrigerant	R290
Application	LBP+MBP
Voltage range	95-140V
Starting torque	HST
Approvals	UL

Electrical accessories / wiring diagram

CSIR

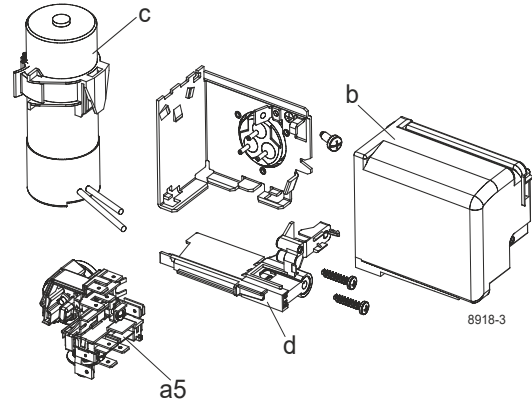

Ambient/ machine room temperatures minimum /maximum

Ambient temperature range:	10 - 43°C / 50 - 110°F
Machine room temperature range:	10 - 48°C / 50 - 119°F
Compressor cooling:	fan 3m/s

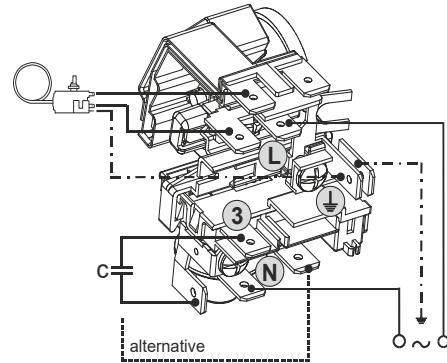

Operation pressure range

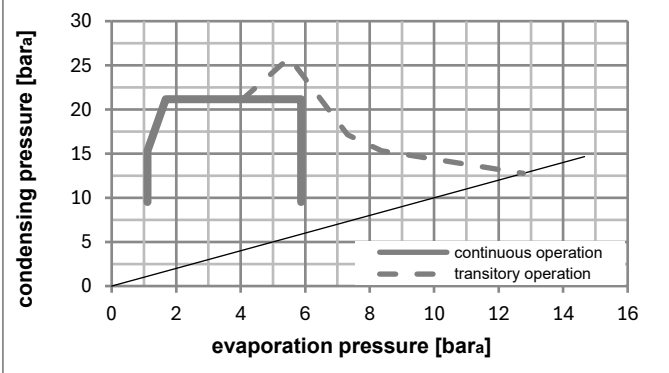
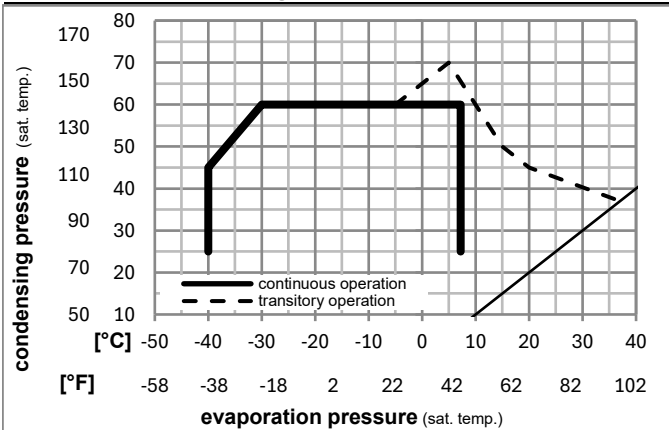

Components

a5	current relay (T1141/L6-S6)	117U7078
c	start capacitor (240µF)	117U5002
b, d	cover + clamp + screws(5VA) in bag	103N1060

Alternative components

b, d	100x cover + clamp + screws(5VA)	103N2060
b, d	cover + clamp + screws(5VA-compl.)	103N0600

Model

Designation **KLF7.7CNH** **115-127V/60Hz** Conf. 1 Sales code: **106H3802**

Optimization + standard conditions

R290, 115V/60Hz, CSIR, fan 3m/s, UL

	Evaporating pressure (saturation temperature)				Condensing pressure (saturation temperature)			Return gas temp.	Liquid temp.	Cooling capacity	COP	EER	Power consumption			ASHRAE LBP
	pe	pc	RGT	Tliq	[W]	[Btu/h]	[kcal/h]						P1	I	m	
	[°C]	[°F]	[°C]	[°F]	[W]	[Btu/h]	[kcal/h]	[W/W]	[Btu/Wh]	[kcal/Wh]	[W]	[A]	[kg/h]			
	-23	54	32	32	475,1	1622	408,9	1,62	5,53	1,39	293,6	3,44	4,81	ASHRAE LBP		
	-10	130	90	90												
	-25	55	32	55	356,6	1218	306,9	1,26	4,32	1,09	282,1	3,36	4,44	cecomaf LBP		
	-13	131	90	131												
	-35	40	20	40	267,4	913	230,1	1,23	4,20	1,06	217,4	2,94	3,05	EN12900 LBP		
	-31	104	68	104												
	-7	54	35	46	842,2	2876	724,8	2,06	7,02	1,77	409,7	4,31	9,61	ASHRAE MBP		
	20	130	95	115												
	-10	55	32	55	668,0	2281	574,9	1,72	5,86	1,48	389,3	4,15	8,45	cecomaf MBP		
	14	131	90	131												
	-10	45	20	45	750,4	2563	645,8	2,08	7,12	1,79	359,9	3,92	9,21	EN12900 MBP		
	14	113	68	113												

Performance tables

R290, 115V/60Hz, CSIR, fan 3m/s, UL

	pe		Cooling capacity			COP	EER	P1	I	m	
	[°C]	[°F]	[W]	[Btu/h]	[kcal/h]	[W/W]	[Btu/Wh]	[kcal/Wh]	[W]	[A]	[kg/h]
[°C / °F]	-40	-40	203,2	694	174,9	1,03	3,52	0,89	197,3	2,84	2,27
cond. pressure	-34	-30	269,8	921	232,2	1,20	4,10	1,03	224,9	2,98	3,02
pc= 45/113	-23	-10	453,5	1549	390,3	1,58	5,41	1,36	286,6	3,38	5,12
return gas temp.	-15	5	643,1	2196	553,5	1,93	6,59	1,66	333,5	3,72	7,32
RGT= 32/90	-4	25	977,1	3337	840,9	2,51	8,58	2,16	388,9	4,14	11,27
liquid temp	0	32	1118,5	3820	962,6	2,76	9,44	2,38	404,7	4,27	12,97
Tliq= 45/113	7,2	45	1417,8	4842	1220,2	3,32	11,34	2,86	427,0	4,45	16,66
[°C / °F]	-40	-40	175,9	601	151,4	0,95	3,25	0,82	185,0	2,76	2,17
cond. pressure	-34	-30	229,9	785	197,9	1,05	3,60	0,91	218,3	2,94	2,84
pc= 55/131	-23	-10	384,1	1312	330,5	1,31	4,46	1,12	294,0	3,44	4,79
return gas temp	-15	5	547,4	1869	471,1	1,55	5,28	1,33	354,0	3,88	6,88
RGT= 32/90	-4	25	840,9	2872	723,7	1,95	6,68	1,68	430,2	4,48	10,73
liquid temp	0	32	966,6	3301	831,9	2,13	7,27	1,83	454,2	4,67	12,42
Tliq= 55/131	7,2	45	1235,0	4218	1062,8	2,51	8,56	2,16	492,9	4,99	16,09

Model

Designation	KLF7.7CNH	115-127V/60Hz	Conf. 2	Sales code:	106H3802
-------------	------------------	----------------------	----------------	-------------	-----------------

Configuration

Motor configuration	RSCR
Power supply (nominal)	115-127V/60Hz 1~
Refrigerant	R290
Application	LBP+MBP
Voltage range	95-140V
Starting torque	LST
Approvals	UL

Electrical accessories / wiring diagram

RSCR

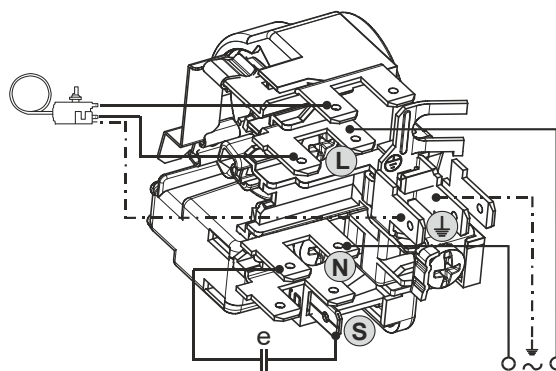
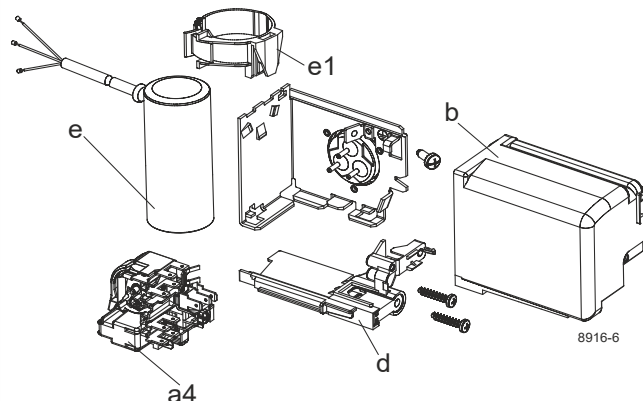

Ambient/ machine room temperatures minimum /maximum

Ambient temperature range: 10 - 43°C / 50 - 110°F

Machine room temperature range: 10 - 48°C / 50 - 119°F

Compressor cooling: fan 3m/s

Operation pressure range

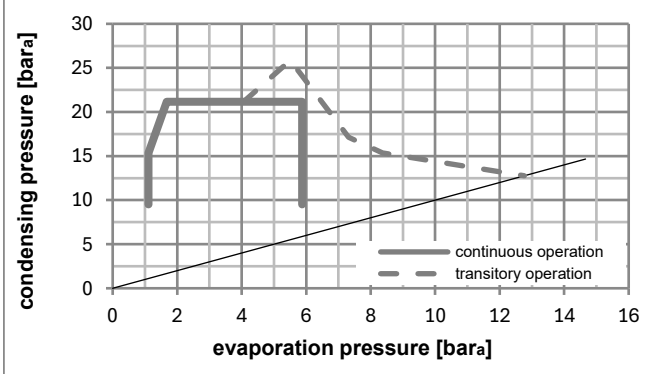
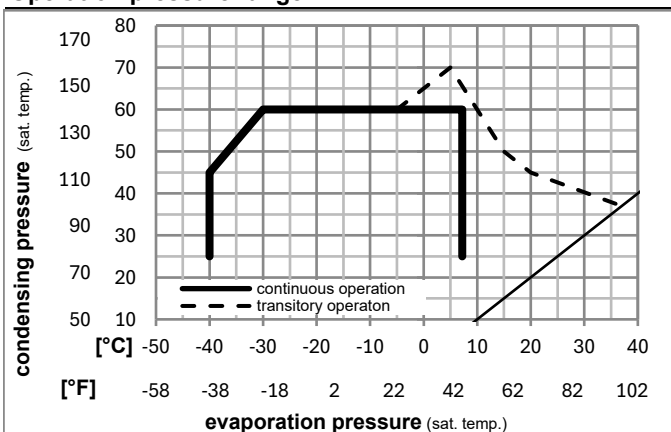

Components

a4	DLS 6 (PTC,6.3mm, T1141/L6 - S6)	103N0214
e	run capacitor (15μF, 6,3mm)	117-7153
b, d	cover + clamp + screws(5VA) in bag	103N1060
e1	retaining clamp	103N0535

Alternative components

b, d	100x cover + clamp + screws(5VA)	103N2060
b, d	cover + clamp + screws(5VA-compl.)	103N0600

Model

Designation **KLF7.7CNH** **115-127V/60Hz** Conf. 2 Sales code: **106H3802**

Optimization + standard conditions

R290, 115V/60Hz, RSCR, fan 3m/s, UL

	Evaporating pressure (saturation temperature)				Cooling capacity			COP	EER			Power consumption			ASHRAE LBP
	pe	pc	RGT	Tliq	[W]	[Btu/h]	[kcal/h]		[W/W]	[Btu/Wh]	[kcal/Wh]	P1	I	m	
	[°C]	[°C]	[°C]	[°C]							[W]	[A]	[kg/h]		
	-23	54	32	32	478,7	1635	412,0	1,71	5,85	1,47	279,6	3,11	4,85	ASHRAE LBP	
	[°F]														
	-10	130	90	90											
	-25	55	32	55	359,4	1228	309,3	1,33	4,54	1,14	270,4	3,04	4,48	cecomaf LBP	
	[°F]														
	-13	131	90	131											
	-35	40	20	40	274,5	937	236,2	1,29	4,40	1,11	213,2	2,67	3,14	EN12900 LBP	
	[°F]														
	-31	104	68	104											
	-7	54	35	46	848,5	2898	730,2	2,22	7,58	1,91	382,5	3,91	9,68	ASHRAE MBP	
	[°F]														
	20	130	95	115											
	-10	55	32	55	675,3	2306	581,2	1,85	6,31	1,59	365,3	3,77	8,54	cecomaf MBP	
	[°F]														
	14	131	90	131											
	-10	45	20	45	761,5	2601	655,3	2,18	7,44	1,87	349,6	3,65	9,35	EN12900 MBP	
	[°F]														
	14	113	68	113											

Performance tables

R290, 115V/60Hz, RSCR, fan 3m/s, UL

	pe		Cooling capacity			COP	EER		P1	I	m
	[°C]	[°F]	[W]	[Btu/h]	[kcal/h]		[W/W]	[Btu/Wh]			
[°C / °F]	-40	-40	200,0	683	172,1	1,07	3,66	0,92	186,4	2,50	2,24
cond. pressure	-34	-30	269,2	919	231,6	1,25	4,27	1,08	215,0	2,67	3,02
pc= 45/113	-23	-10	459,2	1568	395,2	1,65	5,65	1,42	277,6	3,10	5,19
return gas temp.	-15	5	653,0	2230	562,0	2,02	6,88	1,73	324,1	3,45	7,43
RGT= 32/90	-4	25	989,5	3379	851,6	2,63	8,97	2,26	376,9	3,87	11,41
liquid temp	0	32	1130,4	3860	972,8	2,89	9,87	2,49	391,2	3,98	13,11
Tliq= 45/113	7,2	45	1426,4	4872	1227,6	3,48	11,89	3,00	409,8	4,13	16,76
[°C / °F]	-40	-40	166,6	569	143,4	0,91	3,11	0,78	183,1	2,47	2,05
cond. pressure	-34	-30	225,6	770	194,1	1,06	3,62	0,91	212,9	2,64	2,79
pc= 55/131	-23	-10	387,9	1325	333,9	1,38	4,71	1,19	281,0	3,12	4,84
return gas temp	-15	5	554,5	1894	477,2	1,66	5,66	1,43	334,4	3,52	6,97
RGT= 32/90	-4	25	846,2	2890	728,3	2,11	7,22	1,82	400,3	4,05	10,80
liquid temp	0	32	969,1	3310	834,0	2,31	7,88	1,98	420,2	4,22	12,45
Tliq= 55/131	7,2	45	1228,6	4196	1057,3	2,73	9,31	2,35	450,5	4,47	16,01