

Model

Designation	KLF7.7CNHS	115-127V/60Hz 1~	Sales code:	106H3803
-------------	-------------------	------------------	-------------	-----------------

Compressor design

Oil type	Polyolester	Refrigerant(s)	R290
Oil viscosity	19,2cST	Displacement	7,7cm ³ / 0,47cu.in
Oil quantity	162cm ³ / 5,5fl.oz	Compressors on pallet	100
Refr. charge - tech. limit	200g / 7,1oz		
Free gas volume comp.	1575cm ³ / 53,3fl.oz		
Weight	9,7kg / 21,4lbs		
Motor protection	external		
Winding resistance main	1,4Ω (at 25°C)		
Winding resistance aux	5,9Ω (at 25°C)		
Max. winding temp.	125°C / 257°F		
Max. discharge temp.	130°C / 266°F		
Additional note	Very good robustness against liquid intake. Ice-cube maker optimization - indirect suction intake.		



General - Configurations with KLF7.7CNHS

	Conf. 1
Motorconfiguration	CSIR
Power supply (nominal)	115-127V/60Hz
Number of phases	1
Voltage range	95-140V
Approvals	UL
Starting torque	HST
Note	- / -

Applications with KLF7.7CNHS

	Conf. 1
Refrigerant	R290
Application	LBP+MBP
System cooling	fan 3m/s
Hot gas defrost	OK
Long interval pull down	OK

Electrical data - Configurations with KLF7.7CNHS

	Conf. 1
Starting device type	relay
Run capacitor	-/-
Start capacitor	240μF
LRA (locked rotor amps / 4s/ U(N))	35,6A
RLA (rated load amps / 1s/ U(N))	4,9A
Cut in current (U(N))	

Model

Designation

KLF7.7CNHS

115-127V/60Hz 1~

Sales code:

106H3803

Compressor dimensions

Housing	A Height	182mm / 7,17in
	B Height	175mm / 6,89in
	C Length shell	198mm / 7,8in
	D Length w. cover	238mm / 9,37in
	E Width	160mm / 6,3in

Connectors		Suction	Discharge	Process
		X	Y	Z
Diameter	[mm]	øi 8,11-8,29	øi 6,41-6,59	øi 6,41-6,59
	(i:inside, o:outside) [in]	øi 0,32-0,33	øi 0,25-0,26	øi 0,25-0,26
Material		copper	copper	copper
Horizontal angle	±2°	35°	13°	0°
Vertical angle	±2°	30°	40°	145°
Position l/h/w	[mm]	120/72/57	112/106/81	-97/94/72
	[in]	4,7/2,8/2,2	4,4/4,2/3,2	-3,8/3,7/2,8
Straight tube l.	[mm]	14	14	14
	[in]	0,5	0,5	0,5

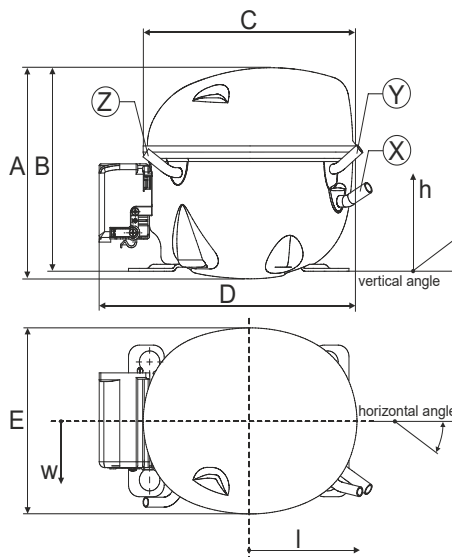

Compressor fixation

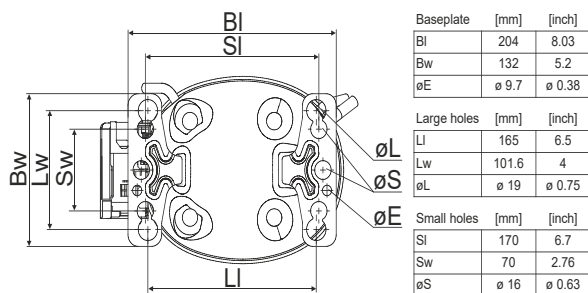

Bolt joint

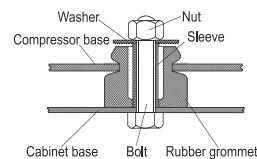

Snap-on

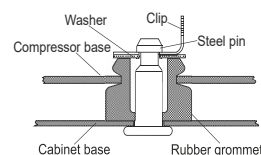

Mounting accessories	one comp.	multi pack
Bolt joint M6 ø16mm	118-1917	118-1918
Bolt joint ø1/4" ø16mm	118-1946	
Bolt joint ø1/4" ø19mm	118-1949	
Snap-on ø7,3 ø16mm	118-1947	118-1919

Application notes

Provision for PE Grounding is located at the PE Stamp on the compressor

Compressor comes on a wooden pallet

Model

Designation	KLF7.7CNHS	115-127V/60Hz	Conf. 1	Sales code:	106H3803
-------------	-------------------	----------------------	---------	-------------	-----------------

Configuration

Motorconfiguration	CSIR
Power supply (nominal)	115-127V/60Hz 1~
Refrigerant	R290
Application	LBP+MBP
Voltage range	95-140V
Starting torque	HST
Approvals	UL

Electrical accessories / wiring diagram

CSIR

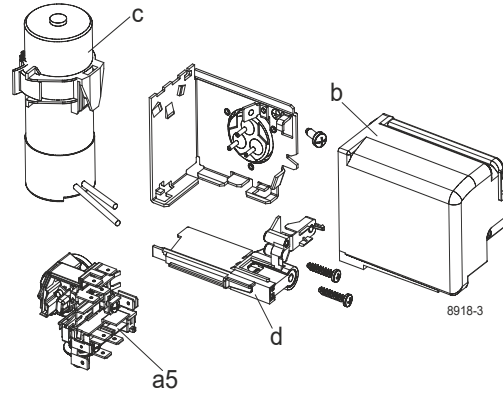

Ambient/ machine room temperatures minimum /maximum

Ambient temperature range:	10 - 43°C / 50 - 110°F
Machine room temperature range:	10 - 48°C / 50 - 119°F
Compressor cooling:	fan 3m/s

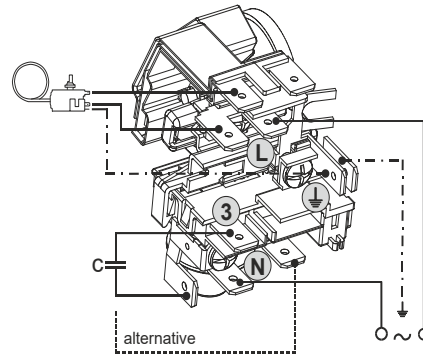

Operation pressure range

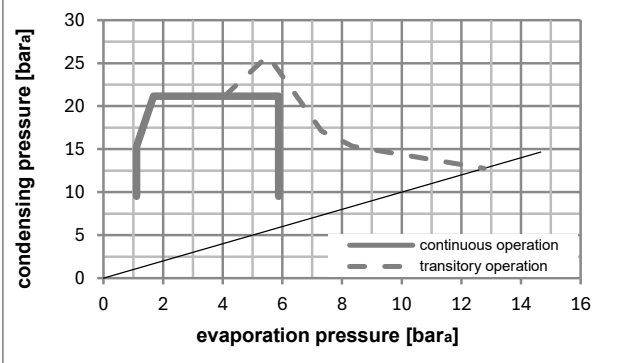
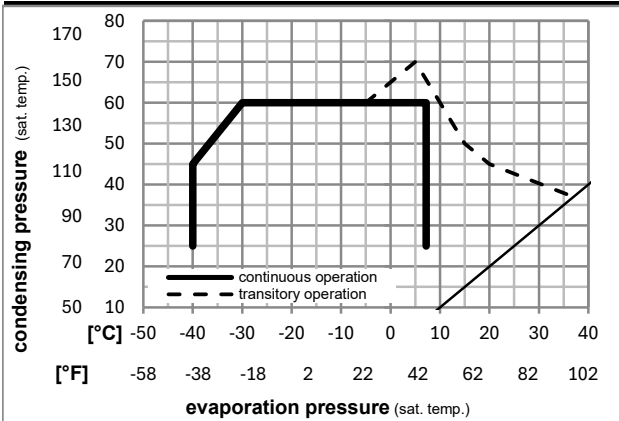

Components

a5	current relay (T1141/L6-S6)	117U7078
c	start capacitor (240µF)	117U5002
b, d	cover + clamp + screws(5VA) in bag	103N1060

Alternative components

b, d	100x cover + clamp + screws(5VA)	103N2060
b, d	cover + clamp + screws(5VA-compl.)	103N0600

Model

Designation **KLF7.7CNHS** **115-127V/60Hz** Conf. 1 Sales code: **106H3803**

Optimization + standard conditions

R290, 115V/60Hz, CSIR, fan 3m/s, UL

Evaporating pressure (saturation temperature)				Condensing pressure (saturation temperature)			Power consumption				Current consumption		Ref. mass flow ṁ	
pe	pc	RGT	Tliq	Cooling capacity	COP	EER	P1	I						
[°C]	[°C]	[°C]	[°C]	[W]	[Btu/h]	[kcal/h]	[W/W]	[Btu/Wh]	[kcal/Wh]	[W]	[A]	[kg/h]		
[°C]	-23	54	32	32	442,5	1511	380,8	1,49	5,10	1,28	296,6	3,46	4,48	ASHRAE LBP
[°F]	-10	130	90	90										
[°C]	-25	55	32	55	333,5	1139	287,0	1,16	3,98	1,00	286,5	3,39	4,15	cecomaf LBP
[°F]	-13	131	90	131										
[°C]	-35	40	20	40	256,7	877	220,9	1,24	4,22	1,06	207,7	2,89	2,93	EN12900 LBP
[°F]	-31	104	68	104										
[°C]	-7	54	35	46	785,5	2683	676,0	1,95	6,64	1,67	403,8	4,26	8,96	ASHRAE MBP
[°F]	20	130	95	115										
[°C]	-10	55	32	55	624,0	2131	537,0	1,61	5,51	1,39	386,5	4,13	7,89	cecomaf MBP
[°F]	14	131	90	131										
[°C]	-10	45	20	45	719,5	2457	619,2	1,97	6,74	1,70	364,5	3,96	8,83	EN12900 MBP
[°F]	14	113	68	113										

Performance tables

R290, 115V/60Hz, CSIR, fan 3m/s, UL

	pe		Cooling capacity			COP	EER	P1	I	m	
	[°C]	[°F]	[W]	[Btu/h]	[kcal/h]	[W/W]	[Btu/Wh]	[kcal/Wh]	[W]	[A]	[kg/h]
[°C / °F]	-40	-40	174,5	596	150,1	1,00	3,43	0,86	173,9	2,69	1,95
cond. pressure	-34	-30	246,5	842	212,1	1,16	3,97	1,00	212,0	2,91	2,76
pc= 45/113	-23	-10	432,0	1475	371,8	1,51	5,15	1,30	286,4	3,39	4,88
return gas temp.	-15	5	616,3	2105	530,4	1,83	6,24	1,57	337,4	3,76	7,01
RGT= 32/90	-4	25	936,7	3199	806,1	2,38	8,14	2,05	393,1	4,18	10,80
liquid temp	0	32	1071,9	3661	922,5	2,63	8,97	2,26	408,1	4,30	12,43
Tliq= 45/113	7,2	45	1358,9	4641	1169,5	3,17	10,84	2,73	428,2	4,46	15,97
[°C / °F]	-40	-40	154,6	528	133,0	0,86	2,94	0,74	179,7	2,72	1,91
cond. pressure	-34	-30	210,7	719	181,3	0,96	3,29	0,83	219,0	2,95	2,61
pc= 55/131	-23	-10	359,5	1228	309,4	1,21	4,12	1,04	298,3	3,47	4,48
return gas temp.	-15	5	512,0	1749	440,7	1,44	4,93	1,24	355,0	3,89	6,44
RGT= 32/90	-4	25	784,5	2679	675,1	1,86	6,36	1,60	421,2	4,40	10,01
liquid temp	0	32	901,5	3079	775,8	2,05	6,99	1,76	440,7	4,56	11,58
Tliq= 55/131	7,2	45	1152,3	3935	991,7	2,45	8,37	2,11	470,2	4,80	15,01