

Model

Designation	KLF7.7MFT	200-240V/50Hz 1~ 208-230V/60Hz 1~	Sales code:	106G2812
-------------	------------------	-----------------------------------	-------------	-----------------

Compressor design

Oil type	Polyolester	Refrigerant(s)	R134a
Oil viscosity	9,7cST	Displacement	7,7cm ³ / 0,47cu.in
Oil quantity	170cm ³ / 5,7fl.oz	Compressors on pallet	100
Refr. charge - tech. limit	400g / 14,1oz		
Free gas volume comp.	1575cm ³ / 53,3fl.oz		
Weight	9,4kg / 20,7lbs		
Motor protection	external		
Winding resistance main	8,4Ω (at 25°C)		
Winding resistance aux	11,9Ω (at 25°C)		
Max. winding temp.	125°C / 257°F		
Max. discharge temp.	130°C / 266°F		



General - Configurations with KLF7.7MFT

	Conf. 1	Conf. 2
Motorconfiguration	CSIR	CSIR
Power supply (nominal)	200-240V/50Hz	208-230V/60Hz
Number of phases	1	1
Voltage range	170-254V	198-253V
Approvals	VDE, UL, CCC	VDE, UL, CCC
Starting torque	HST	HST
Note	Electrical equipment is included and pre-assembled to compressor.	

Applications with KLF7.7MFT

	Conf. 1	Conf. 2
Refrigerant	R134a	R134a
Application	MBP	MBP
System cooling	fan 3m/s	fan 3m/s
Hot gas defrost	OK	OK
Long interval pull down	OK	OK

Electrical data - Configurations with KLF7.7MFT

	Conf. 1	Conf. 2
Starting device type	relay	relay
Run capacitor	-/-	-/-
Start capacitor	80μF	80μF
LRA (locked rotor amps / 4s)	12,3A	12,3A
RLA (rated load amps / 1s)	2,1A	2,1A
Cut in current	12,3A	12,3A

Model

Designation

KLF7.7MFT

200-240V/50Hz 1~ 208-230V/60Hz 1~

Sales code:

106G2812

Compressor dimensions

Housing	A Height	182mm / 7,17in
	B Height	175mm / 6,89in
	C Length shell	198mm / 7,8in
	D Length w. cover	238mm / 9,37in
	E Width	160mm / 6,3in

Connectors		Suction	Discharge	Process
		X	Y	Z
Diameter	[mm]	øi 8,11-8,29	øi 6,11-6,29	øi 6,11-6,29
	(i:inside, o:outside) [in]	øi 0,32-0,33	øi 0,24-0,25	øi 0,24-0,25
Material		copper	copper	copper
Horizontal angle	±2°	35°	13°	0°
Vertical angle	±2°	30°	40°	145°
Position l/h/w	[mm]	120/72/62	112/106/62	-97/102/70
	[in]	4,7/2,8/2,4	4,4/4,2/2,4	-3,8/4/2,8
Straight tube l.	[mm]	14	14	14
	[in]	0,5	0,5	0,5

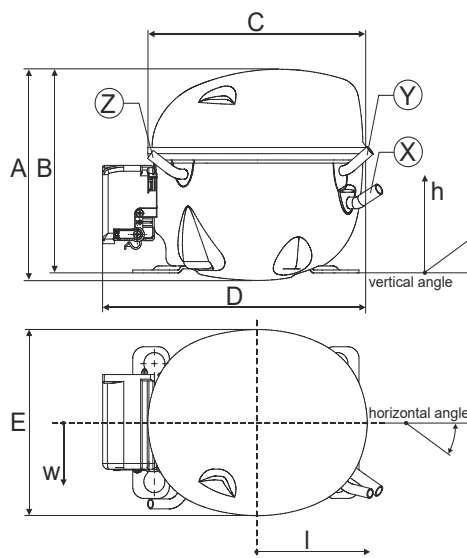

Compressor fixation

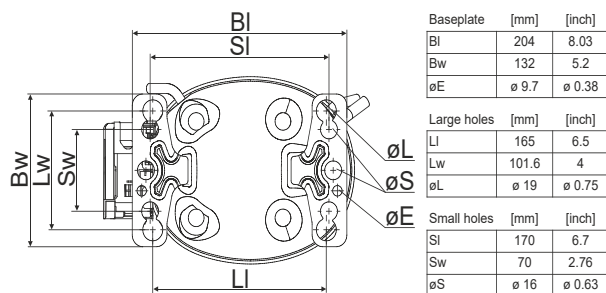

Bolt joint



Snap-on



Mounting accessories

	one comp.	multi pack
Bolt joint M6 ø16mm	118-1917	118-1918
Bolt joint ø1/4" ø16mm	118-1946	
Bolt joint ø1/4" ø19mm	118-1949	
Snap-on ø7,3 ø16mm	118-1947	118-1919

Application notes

Provision for PE Grounding is located at the PE Stamp on the compressor

LRA value on compressor label and datasheet may differ due to different test conditions for UL approval.

Compressor can operate safely in LBP, no official third-party approval yet

Model

Designation	KLF7.7MFT	200-240V/50Hz	Conf. 1	Sales code:	106G2812
-------------	------------------	----------------------	----------------	-------------	-----------------

Configuration

Motorconfiguration	CSIR
Power supply (nominal)	200-240V/50Hz 1~
Refrigerant	R134a
Application	MBP
Voltage range	170-254V
Starting torque	HST
Approvals	VDE
	UL
	CCC

Electrical accessories / wiring diagram

CSIR

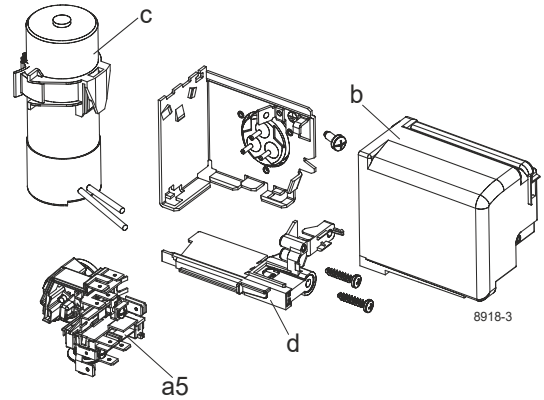

Ambient/ machine room temperatures minimum /maximum

Ambient temperature range:	10 - 43°C / 50 - 110°F
Machine room temperature range:	10 - 48°C / 50 - 119°F

Compressor cooling: fan 3m/s

Compressor with external protector. For max. operation envelope cooling on protector.

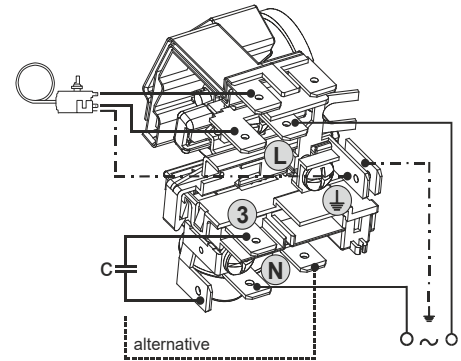
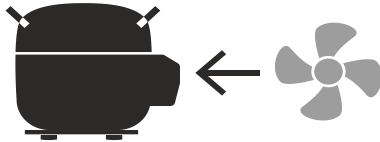

Operation pressure range

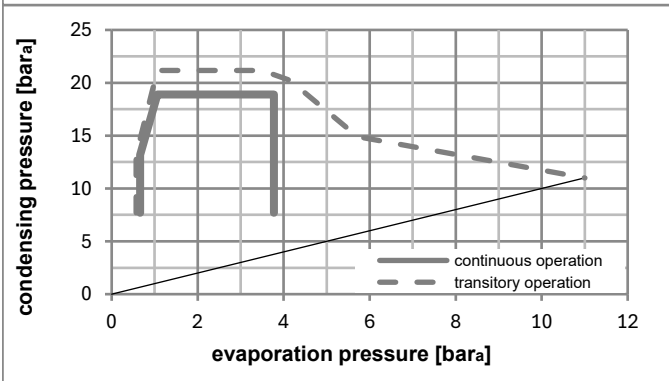
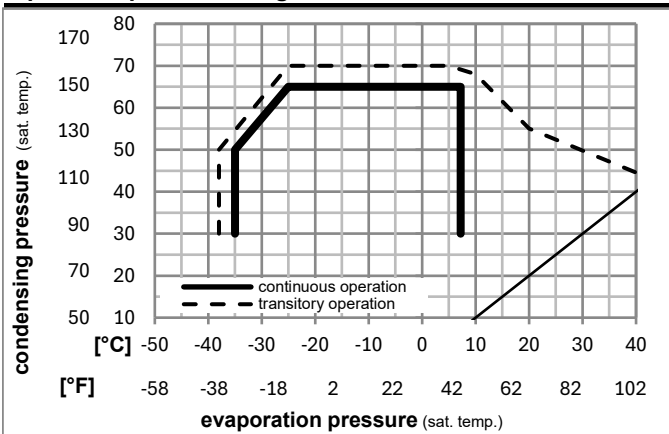

Components (already pre-assembled)

a5	current relay TY (T0377/L6-S1)	117U7071
c	start capacitor (80µF, 6.3mm)	117U5001
b	cover terminal board	10636401
.	screw uni en iso 4757	10641201

Alternative components

.	cable clamp (screws not included)	16058100
.	screw - uni6954	10636000
.	screw - uni6954	10636200

Model

Designation	KLF7.7MFT	200-240V/50Hz	Conf. 1	Sales code:	106G2812
-------------	------------------	----------------------	----------------	-------------	-----------------

Optimization + standard conditions

R134a, 200V/50Hz, CSIR, fan 3m/s, VDE, UL, CCC

Evaporating pressure (saturation temperature)					Condensing pressure (saturation temperature)						Power consumption			
					Return gas temp.			Liquid temp.			Current consumption		Ref. mass flow	
pe	pc	RGT	Tliq		Cooling capacity			COP	EER		P1	I	m	
[°C]	[°C]				[W]	[Btu/h]	[kcal/h]	[W/W]	[Btu/Wh]	[kcal/Wh]	[W]	[A]	[kg/h]	
-7	54	35	46		462,0	1578	397,6	1,89	6,46	1,63	244,1	1,63	10,08	ASHRAE MBP
20	130	95	115											
-10	55	32	55		358,4	1224	308,4	1,58	5,39	1,36	227,2	1,56	8,67	cecomaf MBP
14	131	90	131											
-10	45	20	45		402,0	1373	346,0	1,90	6,50	1,64	211,4	1,50	9,41	EN12900 MBP
14	113	68	113											
-7	49	18	49		437,8	1495	376,8	1,87	6,40	1,61	233,7	1,59	10,81	ARI540 MBP
20	120	65	120											
-10	45	32	45		417,1	1424	358,9	1,97	6,74	1,70	211,4	1,50	9,13	opt
14	113	90	113											
-25	45	32	45		192,7	658	165,9	1,29	4,42	1,11	149,0	1,29	4,18	opt
-13	113	90	113											

Performance tables

R134a, 200V/50Hz, CSIR, fan 3m/s, VDE, UL, CCC

	pe		Cooling capacity			COP	EER		P1	I	m
	[°C]	[°F]	[W]	[Btu/h]	[kcal/h]	[W/W]	[Btu/Wh]	[kcal/Wh]	[W]	[A]	[kg/h]
[°C / °F]	-30	-22	145,0	495	124,8	1,12	3,82	0,96	129,5	1,24	3,13
cond. pressure	-25	-13	192,7	658	165,9	1,29	4,42	1,11	149,0	1,29	4,18
pc= 45/113	-15	5	328,1	1120	282,3	1,73	5,89	1,49	190,1	1,42	7,15
return gas temp.	-10	14	417,1	1424	358,9	1,97	6,74	1,70	211,4	1,50	9,13
RGT= 32/90	-5	23	521,3	1780	448,6	2,24	7,65	1,93	232,9	1,58	11,46
liquid temp	0	32	641,5	2191	552,0	2,52	8,61	2,17	254,4	1,67	14,19
Tliq= 45/113	7,2	45	843,9	2882	726,3	2,96	10,11	2,55	285,1	1,80	18,85
[°C / °F]	-30	-22	118,7	406	102,2	0,90	3,08	0,78	131,8	1,25	2,83
cond. pressure	-25	-13	161,7	552	139,2	1,05	3,60	0,91	153,4	1,31	3,87
pc= 55/131	-15	5	280,8	959	241,6	1,39	4,76	1,20	201,3	1,46	6,76
return gas temp	-10	14	358,4	1224	308,4	1,58	5,39	1,36	227,2	1,56	8,67
RGT= 32/90	-5	23	448,9	1533	386,4	1,77	6,03	1,52	254,2	1,67	10,91
liquid temp	0	32	553,2	1889	476,1	1,96	6,70	1,69	282,0	1,78	13,53
Tliq= 55/131	7,2	45	728,9	2489	627,3	2,25	7,70	1,94	323,3	1,96	18,03

Model

Designation **KLF7.7MFT** **208-230V/60Hz** Conf. 2 Sales code: **106G2812**

Configuration

Motorconfiguration CSIR
 Power supply (nominal) 208-230V/60Hz 1~
 Refrigerant R134a
 Application MBP
 Voltage range 198-253V
 Starting torque HST
 Approvals VDE
 UL
 CCC

Electrical accessories / wiring diagram

CSIR

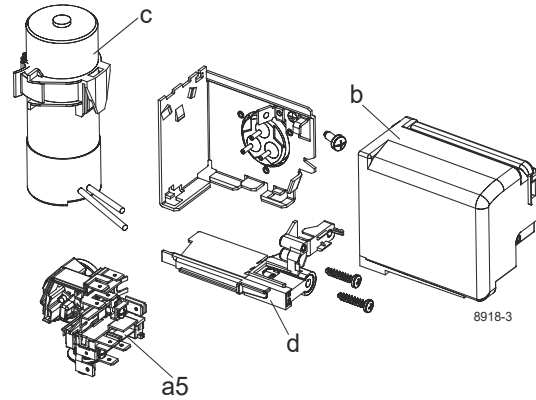

Ambient/ machine room temperatures minimum /maximum

Ambient temperature range: 10 - 43°C / 50 - 110°F

Machine room temperature range: 10 - 48°C / 50 - 119°F

Compressor cooling: fan 3m/s

Compressor with external protector. For max. operation envelope cooling on protector.

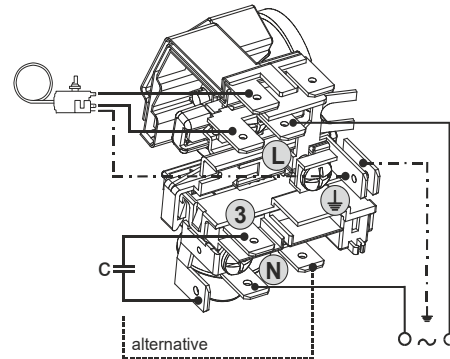
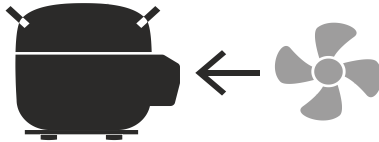

Operation pressure range

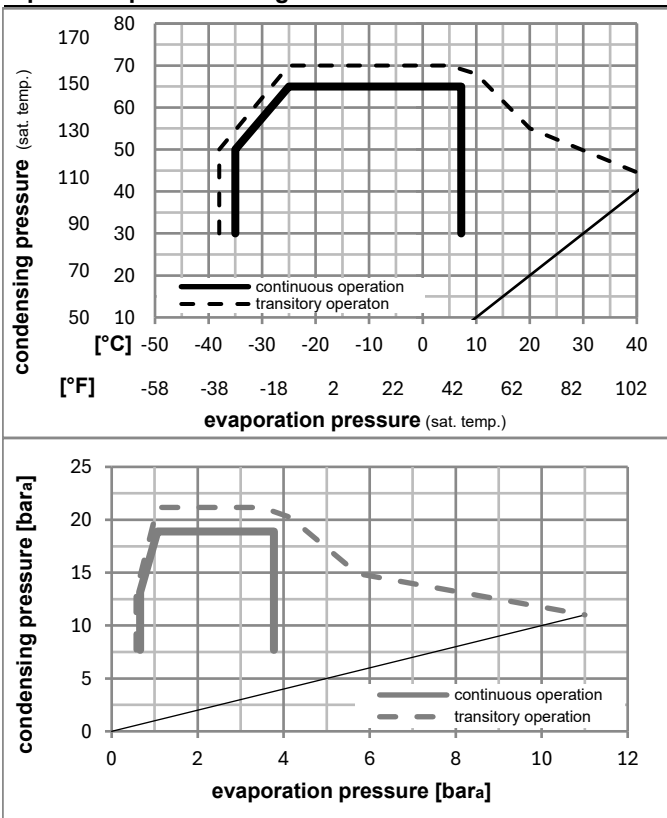

Components (already pre-assembled)

a5	current relay TY (T0377/L6-S1)	117U7071
c	start capacitor (80µF, 6.3mm)	117U5001
b	cover terminal board	10636401
.	screw uni en iso 4757	10641201

Alternative components

.	cable clamp (screws not included)	16058100
.	screw - uni6954	10636000
.	screw - uni6954	10636200

Model

Designation	KLF7.7MFT	208-230V/60Hz	Conf. 2	Sales code:	106G2812
-------------	------------------	----------------------	----------------	-------------	-----------------

Optimization + standard conditions

R134a, 208V/60Hz, CSIR, fan 3m/s, VDE, UL, CCC

		Evaporating pressure (saturation temperature)				Cooling capacity			COP	EER	Power consumption				
		Condensing pressure (saturation temperature)									Current consumption		Ref. mass flow		
		Return gas temp.									I		m		
		Liquid temp.													
		Cooling capacity													
		pe	pc	RGT	Tliq	[W]	[Btu/h]	[kcal/h]	[W/W]	[Btu/Wh]	[kcal/Wh]	P1	I	m	
[°C]	[°F]	[°C]	[°F]	[°C]	[°C]							[W]	[A]	[kg/h]	
-7	20	54	130	35	46	545,0	1861	469,0	1,87	6,40	1,61	290,9	1,65	11,89	ASHRAE MBP
-10	14	55	131	32	55	422,7	1444	363,8	1,56	5,33	1,34	270,6	1,57	10,22	cecomaf MBP
-10	14	45	113	20	45	473,7	1618	407,7	1,89	6,44	1,62	251,1	1,51	11,09	EN12900 MBP
-7	20	49	120	18	49	516,2	1763	444,2	1,86	6,34	1,60	278,2	1,60	12,75	ARI540 MBP
-10	14	45	113	32	45	491,5	1678	422,9	1,96	6,68	1,68	251,1	1,51	10,76	opt
-25	-13	45	113	32	45	226,0	772	194,5	1,29	4,42	1,11	174,6	1,27	4,90	opt

Performance tables

R134a, 208V/60Hz, CSIR, fan 3m/s, VDE, UL, CCC

	pe		Cooling capacity			COP	EER	P1			I	m
	[°C]	[°F]	[W]	[Btu/h]	[kcal/h]	[W/W]	[Btu/Wh]	[kcal/Wh]	[W]	[A]	[kg/h]	
[°C / °F]	-30	-22	169,1	578	145,6	1,13	3,85	0,97	149,9	1,20	3,66	
cond. pressure	-25	-13	226,0	772	194,5	1,29	4,42	1,11	174,6	1,27	4,90	
pc= 45/113	-15	5	386,2	1319	332,4	1,71	5,85	1,48	225,3	1,42	8,42	
return gas temp.	-10	14	491,5	1678	422,9	1,96	6,68	1,68	251,1	1,51	10,76	
RGT= 32/90	-5	23	614,6	2099	529,0	2,22	7,57	1,91	277,1	1,60	13,52	
liquid temp	0	32	756,7	2584	651,2	2,50	8,52	2,15	303,2	1,69	16,73	
Tliq= 45/113	7,2	45	996,2	3402	857,3	2,93	9,99	2,52	340,5	1,83	22,25	
[°C / °F]	-30	-22	139,5	476	120,1	0,91	3,10	0,78	153,6	1,21	3,33	
cond. pressure	-25	-13	190,4	650	163,9	1,05	3,60	0,91	180,7	1,28	4,55	
pc= 55/131	-15	5	331,1	1131	284,9	1,38	4,72	1,19	239,3	1,46	7,97	
return gas temp	-10	14	422,7	1444	363,8	1,56	5,33	1,34	270,6	1,57	10,22	
RGT= 32/90	-5	23	529,7	1809	455,8	1,75	5,97	1,50	303,1	1,69	12,88	
liquid temp	0	32	653,0	2230	562,0	1,94	6,62	1,67	336,7	1,82	15,97	
Tliq= 55/131	7,2	45	861,0	2941	741,0	2,23	7,60	1,92	386,7	2,02	21,29	