

Model

Designation	NF10FX	115-127V/60Hz 1~	Sales code:	105G5941
-------------	---------------	------------------	-------------	-----------------

Compressor design

Oil type	Polyolester	Refrigerant(s)	R134a, R513A, 0
Oil viscosity	32cST	Displacement	10,09cm ³ / 0,62cu.in
Oil quantity	298cm ³ / 10,1fl.oz	Compressors on pallet	80
Refr. charge - tech. limit	460g / 16,2oz		
Free gas volume comp.	2360cm ³ / 79,8fl.oz		
Weight	10kg / 22lbs		
Motor protection	external		
Winding resistance main	1,62Ω (at 25°C)		
Winding resistance aux	4,9Ω (at 25°C)		
Max. winding temp.	125°C / 257°F		
Max. discharge temp.	110°C / 230°F		



General - Configurations with NF10FX

	Conf. 1	Conf. 2
Motorconfiguration	CSIR	CSIR
Power supply (nominal)	115-127V/60Hz	115-127V/60Hz
Number of phases	1	1
Voltage range	95-135V	95-135V
Approvals	UL, CCC, EAC	UL, CCC, EAC
Starting torque	HST	HST
Note	- / -	

Applications with NF10FX

	Conf. 1	Conf. 2
Refrigerant	R134a	R513A
Application	LBP+MBP	LBP+MBP
System cooling	fan 1,5m/s	fan 1,5m/s
Hot gas defrost	OK	OK
Long interval pull down	OK	OK

Electrical data - Configurations with NF10FX

	Conf. 1	Conf. 2
Starting device type	relay	relay
Run capacitor	- / -	- / -
Start capacitor	320μF	320μF
LRA (locked rotor amps / 4s/ U(N))	30,8A	30,8A
RLA (rated load amps / 1s/ U(N))	4,9A	4,9A
Cut in current (U(N))	30,8A	30,8A

Model

Designation

NF10FX

115-127V/60Hz 1~

Sales code:

105G5941

Compressor dimensions

Housing	A Height	197mm / 7,76in
	B Height	191mm / 7,52in
	C Length shell	205mm / 8,07in
	D Length w. cover	254mm / 10in
	E Width	166mm / 6,54in

Connectors		Suction	Discharge	Process
		X	Y	Z
Diameter	[mm]	øi 8,11-8,29	øi 6,41-6,59	øi 6,41-6,59
(i:inside, o:outside)	[in]	øi 0,32-0,33	øi 0,25-0,26	øi 0,25-0,26
Material		copper	copper	copper
Horizontal angle	±2°	0°	0°	0°
Vertical angle	±2°	15°	35°	155°
Position l/h/w	[mm]	126/76/78	133/103/54	-107/94/72
	[in]	4,9/3/3,1	5,2/4/2,1	-4,2/3,7/2,8
Straight tube l.	[mm]	12	12	12
	[in]	0,5	0,5	0,5

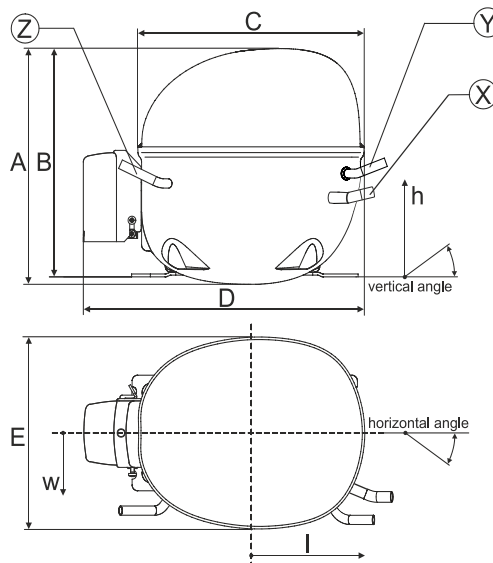

Compressor fixation

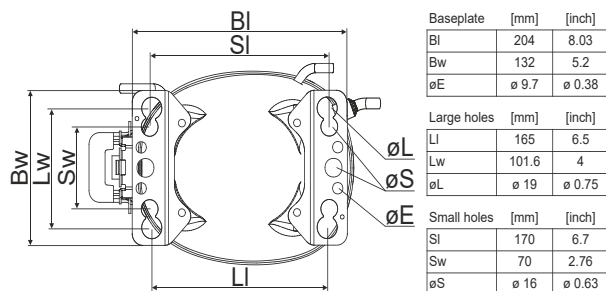

Bolt joint



Snap-on

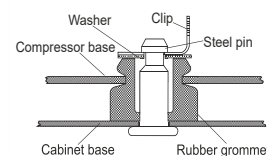

Mounting accessories	one comp.	multi pack
Bolt joint M6 ø16mm	118-1917	118-1918
Bolt joint ø1/4" ø16mm	118-1946	
Bolt joint ø1/4" ø19mm	118-1949	
Snap-on ø7,3 ø16mm	118-1947	118-1919

Application notes

Provision for PE Grounding is located at the PE Stamp on the compressor

Model

Designation	NF10FX	115-127V/60Hz	Conf. 1	Sales code:	105G5941
-------------	---------------	----------------------	----------------	-------------	-----------------

Configuration

Motor configuration	CSIR	
Power supply (nominal)	115-127V/60Hz 1~	
Refrigerant	R134a	
Application	LBP+MBP	
Voltage range	95-135V	
Starting torque	HST	
Approvals	UL	SA3693
	CCC	
	EAC	

Electrical accessories / wiring diagram

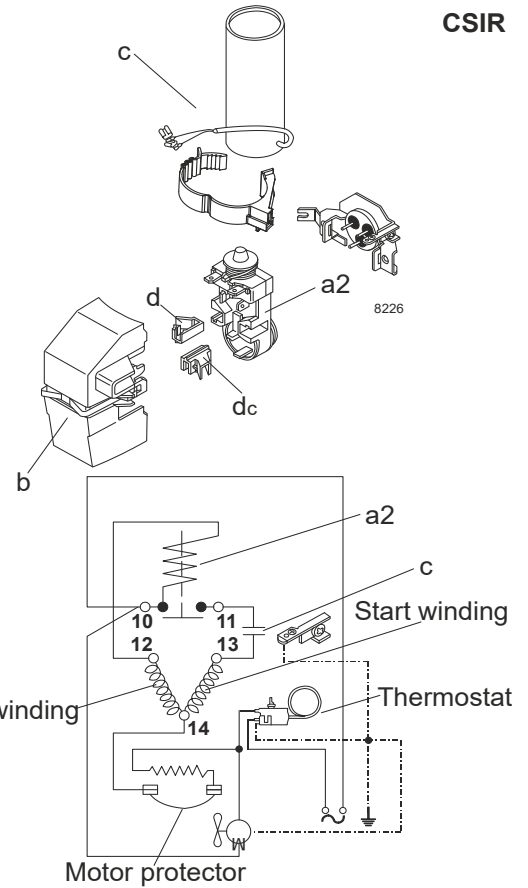

Ambient/ machine room temperatures minimum /maximum

Ambient temperature range:	10 - 43°C / 50 - 110°F
Machine room temperature range:	10 - 48°C / 50 - 119°F
Compressor cooling:	fan 3m/s

Operation pressure range

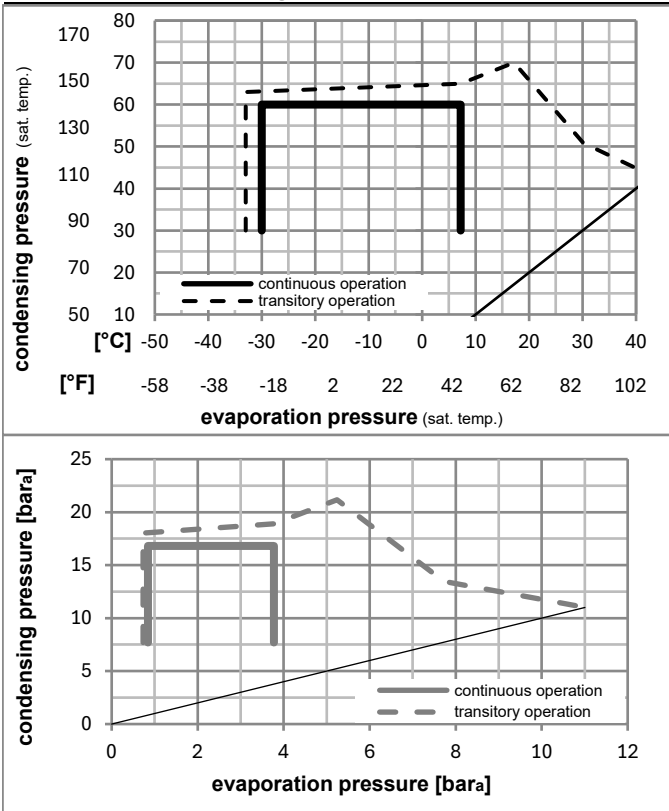

Components

a2	current relay (MRT22AFZ-6)	117U4129
c	start capacitor (320µF)	117U5022
b	plastic cover	117U1021
d/dc	cord relief	117U0349
dc	cord relief	117U0349

Model

Designation **NF10FX** **115-127V/60Hz** Conf. 1 Sales code: **105G5941**

Optimization + standard conditions

R134a, 115V/60Hz, CSIR, fan 3m/s, UL, CCC, EAC

	Evaporating pressure (saturation temperature)				Condensing pressure (saturation temperature)			Return gas temp.	Liquid temp.	Cooling capacity	COP	EER	Power consumption			
	pe	pc	RGT	Tliq	[W]	[Btu/h]	[kcal/h]						P1	I	Ref. mass flow	
	[°C]	[°F]	[°C]	[°F]	[W]	[Btu/h]	[kcal/h]	[W/W]	[Btu/Wh]	[kcal/Wh]	[W]	[A]	[kg/h]			
ASHRAE LBP	-23	54	32	32	306,9	1048	264,1	1,17	4,01	1,01	261,4	3,71	5,96			
cecomaf LBP	-25	55	32	55	226,6	774	195,0	0,91	3,09	0,78	250,4	3,64	5,42			
EN12900 LBP	-35	40	20	40	144,9	495	124,7	0,81	2,76	0,70	179,3	3,33	3,18			
ASHRAE MBP	-7	54	35	46	626,9	2141	539,5	1,60	5,48	1,38	390,7	4,55	13,68			
cecomaf MBP	-10	55	32	55	488,2	1667	420,2	1,34	4,58	1,15	363,8	4,37	11,81			
EN12900 MBP	-10	45	20	45	541,0	1848	465,6	1,56	5,32	1,34	347,2	4,24	12,66			

Performance tables

R134a, 115V/60Hz, CSIR, fan 3m/s, UL, CCC, EAC

	pe		Cooling capacity			COP	EER	P1	I	m	
	[°C]	[°F]	[W]	[Btu/h]	[kcal/h]	[W/W]	[Btu/Wh]	[kcal/Wh]	[W]	[A]	[kg/h]
[°C / °F]	-30	-22	189,5	647	163,1	0,89	3,05	0,77	212,3	3,46	4,10
cond. pressure	-23	-10	284,2	971	244,6	1,12	3,81	0,96	254,9	3,69	6,16
pc= 45/113	-15	5	441,6	1508	380,1	1,42	4,84	1,22	311,9	4,02	9,63
return gas temp.	-9	15	575,9	1967	495,6	1,64	5,60	1,41	351,1	4,26	12,61
RGT= 32/90	-4	25	737,6	2519	634,8	1,89	6,45	1,62	390,7	4,53	16,24
liquid temp	0	32	868,9	2967	747,8	2,08	7,09	1,79	418,3	4,73	19,21
Tliq= 45/113	7,2	45	1156,7	3950	995,4	2,47	8,43	2,13	468,4	5,13	25,84
[°C / °F]	-30	-22	165,4	565	142,4	0,76	2,59	0,65	218,5	3,43	3,94
cond. pressure	-23	-10	249,4	852	214,6	0,95	3,25	0,82	261,8	3,72	5,97
pc= 55/131	-15	5	385,5	1317	331,8	1,19	4,07	1,03	323,5	4,11	9,28
return gas temp	-9	15	500,7	1710	430,9	1,36	4,64	1,17	368,4	4,40	12,11
RGT= 32/90	-4	25	639,4	2184	550,3	1,54	5,26	1,32	415,6	4,72	15,56
liquid temp	0	32	752,3	2569	647,5	1,67	5,71	1,44	449,6	4,95	18,40
Tliq= 55/131	7,2	45	1000,9	3418	861,4	1,95	6,65	1,68	514,2	5,40	24,76

Model

Designation	NF10FX	115-127V/60Hz	Conf. 2	Sales code:	105G5941
-------------	---------------	----------------------	----------------	-------------	-----------------

Configuration

Motor configuration	CSIR	
Power supply (nominal)	115-127V/60Hz 1~	
Refrigerant	R513A	
Application	LBP+MBP	
Voltage range	95-135V	
Starting torque	HST	
Approvals	UL	SA3693
	CCC	
	EAC	

Electrical accessories / wiring diagram

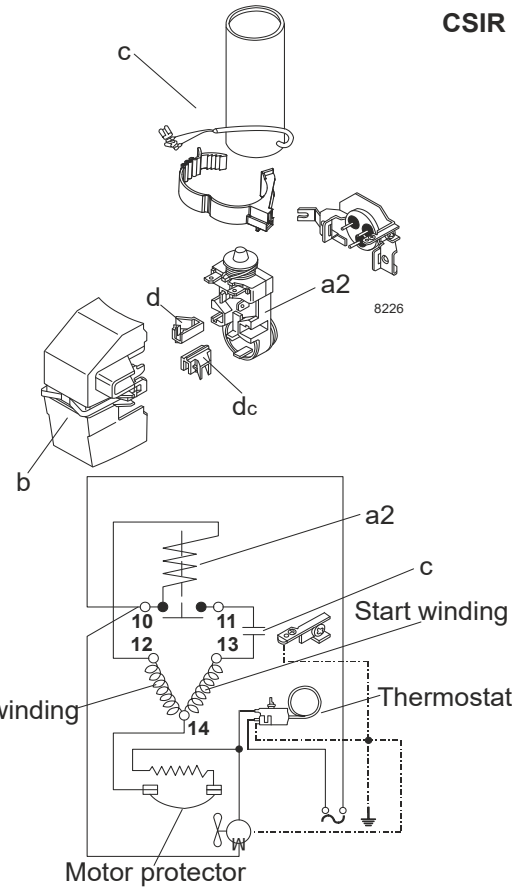

Ambient/ machine room temperatures minimum /maximum

Ambient temperature range:	10 - 43°C / 50 - 110°F
Machine room temperature range:	10 - 48°C / 50 - 119°F
Compressor cooling:	fan 3m/s

Operation pressure range

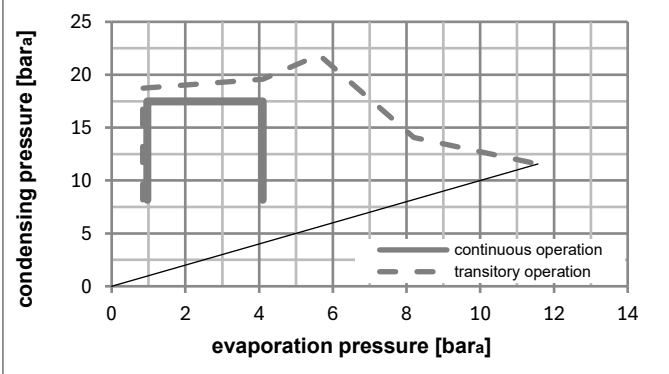
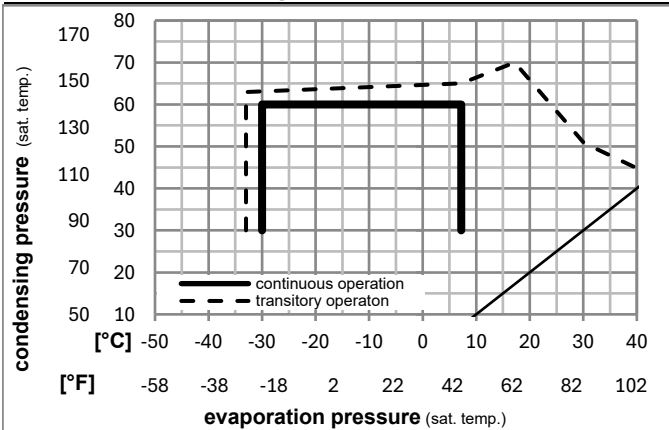

Components

a2	current relay (MRT22AFZ-6)	117U4129
c	start capacitor (320µF)	117U5022
b	plastic cover	117U1021
d/dc	cord relief	117U0349
dc	cord relief	117U0349

Model

Designation **NF10FX** **115-127V/60Hz** Conf. 2 Sales code: **105G5941**

Optimization + standard conditions

R513A, 115V/60Hz, CSIR, fan 3m/s, UL, CCC, EAC

	Evaporating pressure (saturation temperature)				Cooling capacity			COP	EER			Power consumption			ASHRAE LBP
	pe	pc	RGT	Tliq	[W]	[Btu/h]	[kcal/h]		[W/W]	[Btu/Wh]	[kcal/Wh]	P1	I	m	
	[°C]	[°C]	[°C]	[°C]							[W]	[A]	[kg/h]		
	-23	54	32	32	338,9	1157	291,6	1,19	4,05	1,02	285,9	3,92	7,29	ASHRAE LBP	
	[°F]														
	-10	130	90	90											
	-25	55	32	55	243,4	831	209,5	0,89	3,02	0,76	275,0	3,85	6,67	cecomaf LBP	
	[°F]														
	-13	131	90	131											
	-35	40	20	40	161,5	552	139,0	0,81	2,78	0,70	198,2	3,36	3,99	EN12900 LBP	
	[°F]														
	-31	104	68	104											
	-7	54	35	46	657,3	2245	565,7	1,58	5,39	1,36	416,4	4,76	16,10	ASHRAE MBP	
	[°F]														
	20	130	95	115											
	-10	55	32	55	506,0	1728	435,5	1,30	4,44	1,12	389,2	4,58	13,99	cecomaf MBP	
	[°F]														
	14	131	90	131											
	-10	45	20	45	564,9	1929	486,1	1,52	5,20	1,31	370,7	4,47	14,97	EN12900 MBP	
	[°F]														
	14	113	68	113											

Performance tables

R513A, 115V/60Hz, CSIR, fan 3m/s, UL, CCC, EAC

	pe		Cooling capacity			COP	EER		P1	I	m
	[°C]	[°F]	[W]	[Btu/h]	[kcal/h]		[W/W]	[Btu/Wh]			
[°C / °F]	-30	-22	208,9	714	179,8	0,89	3,06	0,77	233,5	3,59	5,08
cond. pressure	-23	-10	307,5	1050	264,6	1,11	3,79	0,96	276,9	3,87	7,50
pc= 45/113	-15	5	469,1	1602	403,7	1,40	4,78	1,21	334,9	4,24	11,49
return gas temp.	-9	15	605,5	2068	521,1	1,62	5,52	1,39	374,7	4,49	14,89
RGT= 32/90	-4	25	768,5	2625	661,4	1,85	6,33	1,59	414,7	4,75	18,99
liquid temp	0	32	900,2	3074	774,7	2,04	6,95	1,75	442,3	4,92	22,33
Tliq= 45/113	7,2	45	1187,3	4055	1021,8	2,41	8,24	2,08	492,0	5,24	29,70
[°C / °F]	-30	-22	180,8	617	155,6	0,74	2,54	0,64	243,2	3,65	4,94
cond. pressure	-23	-10	266,6	911	229,5	0,93	3,18	0,80	286,4	3,93	7,31
pc= 55/131	-15	5	403,7	1379	347,4	1,16	3,96	1,00	348,5	4,32	11,12
return gas temp	-9	15	518,4	1770	446,1	1,32	4,49	1,13	393,9	4,61	14,34
RGT= 32/90	-4	25	655,5	2239	564,1	1,48	5,07	1,28	441,5	4,92	18,23
liquid temp	0	32	766,5	2618	659,6	1,61	5,50	1,39	475,9	5,14	21,41
Tliq= 55/131	7,2	45	1009,7	3448	868,9	1,87	6,37	1,61	540,9	5,56	28,46