

Model

Designation	NF5.5CLX	115-127V/60Hz 1~	Sales code:	105F1611
-------------	-----------------	------------------	-------------	-----------------

Compressor design

Oil type	Polyolester	Refrigerant(s)	R404A, R507
Oil viscosity	32cST	Displacement	6,13cm ³ / 0,37cu.in
Oil quantity	298cm ³ / 10,1fl.oz	Compressors on pallet	80
Refr. charge - tech. limit	400g / 14,1oz		
Free gas volume comp.	2280cm ³ / 77,1fl.oz		
Weight	10kg / 22lbs		
Motor protection	1# internal		
Winding resistance main	1,6Ω (at 25°C)		
Winding resistance aux	6,2Ω (at 25°C)		
Max. winding temp.	125°C / 257°F		
Max. discharge temp.	130°C / 266°F		



General - Configurations with NF5.5CLX

	Conf. 1
Motorconfiguration	CSIR
Power supply (nominal)	115V/60Hz
Number of phases	1
Voltage range	95-135V
Approvals	CCC, EAC, UL
Starting torque	HST
Note	- / -

Applications with NF5.5CLX

	Conf. 1
Refrigerant	R404A
Application	LBP+MBP
System cooling	fan 1,5m/s
Hot gas defrost	- / -
Long interval pull down	OK

Electrical data - Configurations with NF5.5CLX

	Conf. 1
Starting device type	relay
Run capacitor	- / -
Start capacitor	280μF
LRA (locked rotor amps / 4s)	30,8A
RLA (rated load amps / 1s)	4,7A
Cut in current	

Model

Designation

NF5.5CLX

115-127V/60Hz 1~

Sales code:

105F1611

Compressor dimensions

Housing	A Height	197mm / 7,76in
	B Height	191mm / 7,52in
	C Length shell	205mm / 8,07in
	D Length w. cover	254mm / 10in
	E Width	166mm / 6,54in

Connectors		Suction	Discharge	Process
		X	Y	Z
Diameter	[mm]	øi 8,11-8,29	øi 6,41-6,59	øi 6,41-6,59
	(i:inside, o:outside) [in]	øi 0,32-0,33	øi 0,25-0,26	øi 0,25-0,26
Material		copper	copper	copper
Horizontal angle	±2°	0°	0°	0°
Vertical angle	±2°	15°	35°	155°
Position l/h/w	[mm]	126/76/78	133/103/54	-107/94/72
	[in]	4,9/3/3,1	5,2/4/2,1	-4,2/3,7/2,8
Straight tube l.	[mm]	12	12	12
	[in]	0,5	0,5	0,5

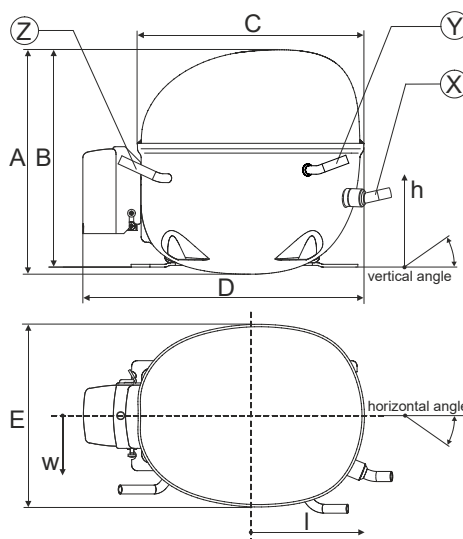

Compressor fixation

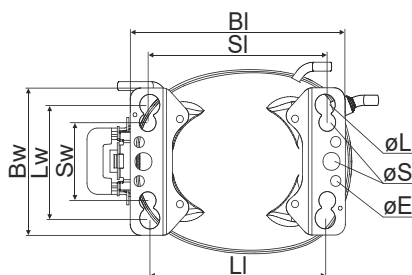

Baseplate	[mm]	[inch]
BI	204	8.03
BW	132	5.2
øE	ø 9.7	ø 0.38
Large holes		
LI	165	6.5
Lw	101.6	4
øL	ø 19	ø 0.75
Small holes		
SI	170	6.7
Sw	70	2.76
øS	ø 16	ø 0.63

Bolt joint

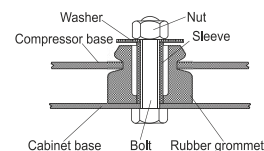

Snap-on

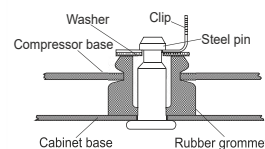

Mounting accessories

	one comp.	multi pack
Bolt joint M6 ø16mm	118-1917	118-1918
Bolt joint ø1/4" ø16mm	118-1946	
Bolt joint ø1/4" ø19mm	118-1949	
Snap-on ø7,3 ø16mm	118-1947	118-1919

Application notes

LRA value on compressor label and datasheet may differ due to different test conditions for UL approval.

Model

Designation	NF5.5CLX	115V/60Hz	Conf. 1	Sales code:	105F1611
-------------	-----------------	------------------	----------------	-------------	-----------------

Configuration

Motorconfiguration	CSIR
Power supply (nominal)	115V/60Hz 1~
Refrigerant	R404A
Application	LBP+MBP
Voltage range	95-135V
Starting torque	HST
Approvals	CCC EAC UL

Electrical accessories / wiring diagram

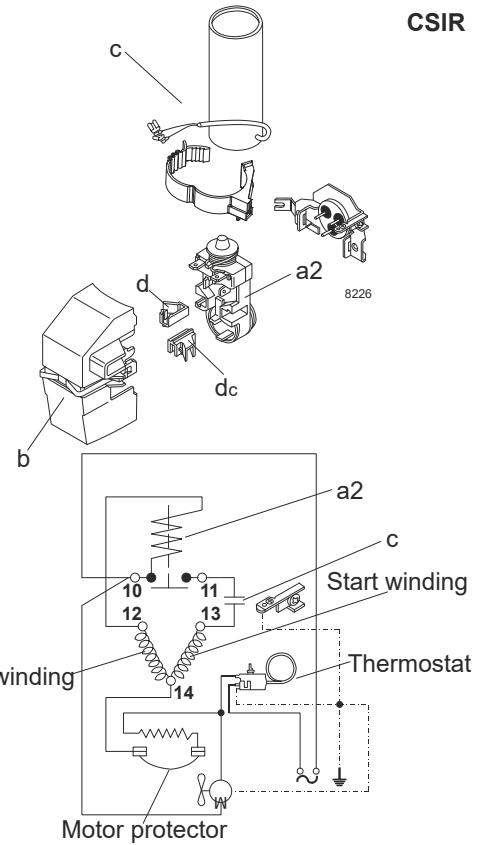

Ambient temperatures / system cooling

Ambient temperature min.:	10°C / 50°F
Ambient temperature max.:	43°C / 110°F

System cooling (n/a: outside limits)			
T ambient	LBP	MBP	HBP
32°C / 90°F	fan 1,5m/s	fan 1,5m/s	n/a
38°C / 100°F	fan 1,5m/s	fan 1,5m/s	n/a
43°C / 110°F	fan 3m/s	fan 1,5m/s	n/a

Operation pressure range

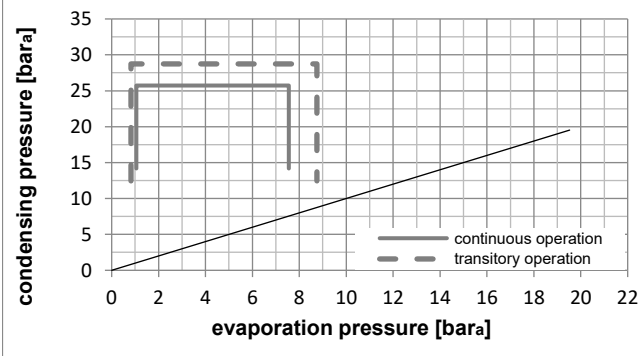
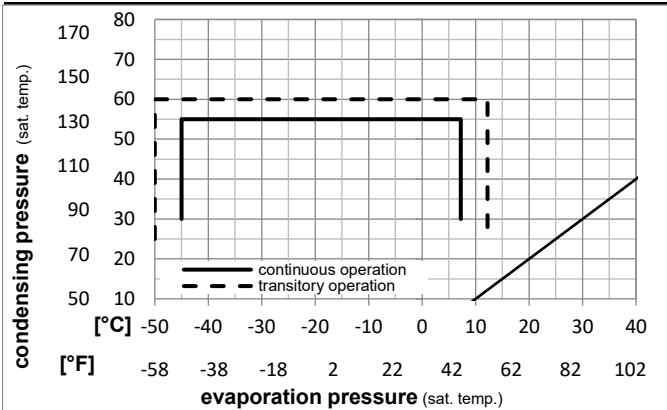

Components

a2	relay (protector: TI MRP30AEN-6)	117U4061
c	start capacitor (280µF)	117U5025
b	plastic cover	117U1021
d/dc	cord relief	117U0349
d/dc	cord relief	117U0349

Alternative components

b	assy. terminal board 6.3mm	117U1024
---	----------------------------	----------

Model

Designation	NF5.5CLX	115V/60Hz	Conf. 1	Sales code:	105F1611
-------------	-----------------	------------------	----------------	-------------	-----------------

Optimization + standard conditions

R404A, 115V/60Hz, CSIR, fan 3m/s, CCC, EAC, UL

		Evaporating pressure (saturation temperature)				Condensing pressure (saturation temperature)			Return gas temp.		Liquid temp.		Cooling capacity			COP	EER	Power consumption			ASHRAE LBP
		pe	pc	RGT	Tliq	[W]	[Btu/h]	[kcal/h]	[W/W]	[Btu/Wh]	[kcal/Wh]	P1	I	Current consumption		Ref. mass flow	cecomaf LBP				
[°C]	[°F]	[°C]	[°F]	[°C]	[°C]							[W]	[A]	[kg/h]							
-23	54	32	32	365,3	1247	314,4	1,23	4,20	1,06	297,3	3,97	8,51									
-10	130	90	90																		
-25	55	32	55	248,4	848	213,8	0,87	2,97	0,75	285,5	3,90	7,76									
-13	131	90	131																		
-35	40	20	40	203,3	694	174,9	0,95	3,23	0,81	215,0	3,53	5,52									
-31	104	68	104																		
-7	54	35	46	653,9	2233	562,8	1,53	5,22	1,32	427,7	4,81	17,99									
20	130	95	115																		
-10	55	32	55	489,9	1673	421,6	1,22	4,18	1,05	400,6	4,63	15,68									
14	131	90	131																		
-10	45	20	45	569,0	1943	489,7	1,49	5,08	1,28	382,2	4,48	17,14									
14	113	68	113																		

Performance tables

R404A, 115V/60Hz, CSIR, fan 3m/s, CCC, EAC, UL

	pe		Cooling capacity			COP	EER	P1	I	m	
	[°C]	[°F]	[W]	[Btu/h]	[kcal/h]	[W/W]	[Btu/Wh]	[kcal/Wh]	[W]	[A]	[kg/h]
[°C / °F]	-45	-49	97,3	332	83,8	0,64	2,17	0,55	153,1	3,35	2,59
cond. pressure	-34	-30	196,2	670	168,8	0,89	3,05	0,77	219,4	3,55	5,25
pc= 45/113	-23	-10	345,0	1178	296,9	1,19	4,07	1,03	289,6	3,89	9,32
return gas temp.	-15	5	495,1	1691	426,1	1,43	4,89	1,23	345,8	4,23	13,53
RGT= 32/90	-4	25	758,1	2589	652,4	1,76	6,02	1,52	430,2	4,81	21,12
liquid temp	0	32	869,4	2969	748,2	1,88	6,41	1,62	463,2	5,04	24,44
Tliq= 45/113	7,2	45	1105,7	3776	951,6	2,08	7,12	1,79	530,4	5,52	31,71
[°C / °F]	-45	-49	65,7	224	56,5	0,46	1,58	0,40	141,7	3,32	2,02
cond. pressure	-34	-30	146,5	500	126,0	0,67	2,30	0,58	217,9	3,57	4,53
pc= 55/131	-23	-10	270,0	922	232,3	0,91	3,10	0,78	297,6	3,97	8,46
return gas temp	-15	5	396,9	1355	341,5	1,10	3,76	0,95	360,5	4,36	12,59
RGT= 32/90	-4	25	623,2	2128	536,3	1,38	4,70	1,18	453,0	4,99	20,23
liquid temp	0	32	720,1	2459	619,7	1,47	5,03	1,27	488,6	5,24	23,61
Tliq= 55/131	7,2	45	927,7	3168	798,4	1,66	5,65	1,42	560,5	5,76	31,14