

Customer specific model

Model

Designation	NF5.5FX	115-127V/60Hz 1~	Sales code:	105G5626
-------------	----------------	------------------	-------------	-----------------

Compressor design

Oil type	Polyolester	Refrigerant(s)	R134a, R513A, 0
Oil viscosity	32cST	Displacement	6,13cm ³ / 0,37cu.in
Oil quantity	268cm ³ / 9,1fl.oz	Compressors on pallet	80
Refr. charge - tech. limit	500g / 17,6oz		
Free gas volume comp.	2360cm ³ / 79,8fl.oz		
Weight	10kg / 22lbs		
Motor protection	external		
Winding resistance main	2Ω (at 25°C)		
Winding resistance aux	3,1Ω (at 25°C)		
Max. winding temp.	125°C / 257°F		
Max. discharge temp.	130°C / 266°F		



General - Configurations with NF5.5FX

	Conf. 1	Conf. 2
Motorconfiguration	CSIR	CSIR
Power supply (nominal)	115-127V/60Hz	115-127V/60Hz
Number of phases	1	1
Voltage range	95-135V	95-135V
Approvals	UL, EAC	UL, EAC
Starting torque	HST	HST
Note	- / -	

Applications with NF5.5FX

	Conf. 1	Conf. 2
Refrigerant	R134a	R513A
Application	LBP+MBP	LBP+MBP
System cooling	fan 1,5m/s	fan 1,5m/s
Hot gas defrost	-/-	-/-
Long interval pull down	OK	OK

Electrical data - Configurations with NF5.5FX

	Conf. 1	Conf. 2
Starting device type	relay	relay
Run capacitor	-/-	-/-
Start capacitor	280μF	280μF
LRA (locked rotor amps / 4s/ U(N))	22,2A	22,2A
RLA (rated load amps / 1s/ U(N))	3,7A	3,7A
Cut in current (U(N))		

Customer specific model

Model

Designation

NF5.5FX

115-127V/60Hz 1~

Sales code:

105G5626

Compressor dimensions

Housing	A Height	197mm / 7,76in
	B Height	191mm / 7,52in
	C Length shell	205mm / 8,07in
	D Length w. cover	254mm / 10in
	E Width	166mm / 6,54in

Connectors		Suction	Discharge	Process
		X	Y	Z
Diameter	[mm]	øi 8,11-8,29	øi 6,41-6,59	øi 6,41-6,59
	(i:inside, o:outside) [in]	øi 0,32-0,33	øi 0,25-0,26	øi 0,25-0,26
Material		copper	copper	copper
Horizontal angle	±2°	0°	0°	0°
Vertical angle	±2°	15°	35°	155°
Position l/h/w	[mm]	126/76/78	133/103/54	-107/94/72
	[in]	4,9/3/3,1	5,2/4/2,1	-4,2/3,7/2,8
Straight tube l.	[mm]	12	12	12
	[in]	0,5	0,5	0,5

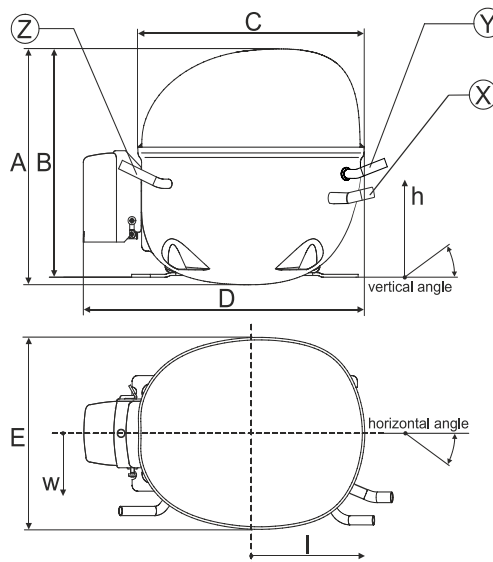

Compressor fixation

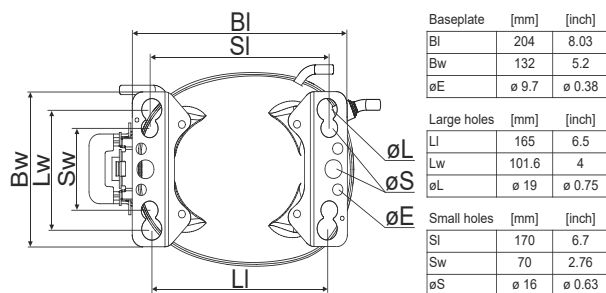

Bolt joint

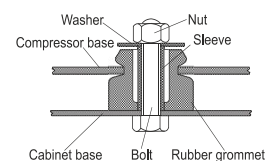

Snap-on

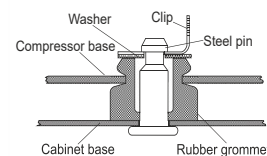

Mounting accessories

	one comp.	multi pack
Bolt joint M6 ø16mm	118-1917	118-1918
Bolt joint ø1/4" ø16mm	118-1946	
Bolt joint ø1/4" ø19mm	118-1949	
Snap-on ø7,3 ø16mm	118-1947	118-1919

Application notes

Provision for PE Grounding is located at the PE Stamp on the compressor

Customer specific model

Model

Designation	NF5.5FX	115-127V/60Hz	Conf. 1	Sales code:	105G5626
-------------	----------------	----------------------	---------	-------------	-----------------

Configuration

Motorconfiguration	CSIR
Power supply (nominal)	115-127V/60Hz 1~
Refrigerant	R134a
Application	LBP+MBP
Voltage range	95-135V
Starting torque	HST
Approvals	UL
	EAC

Electrical accessories / wiring diagram

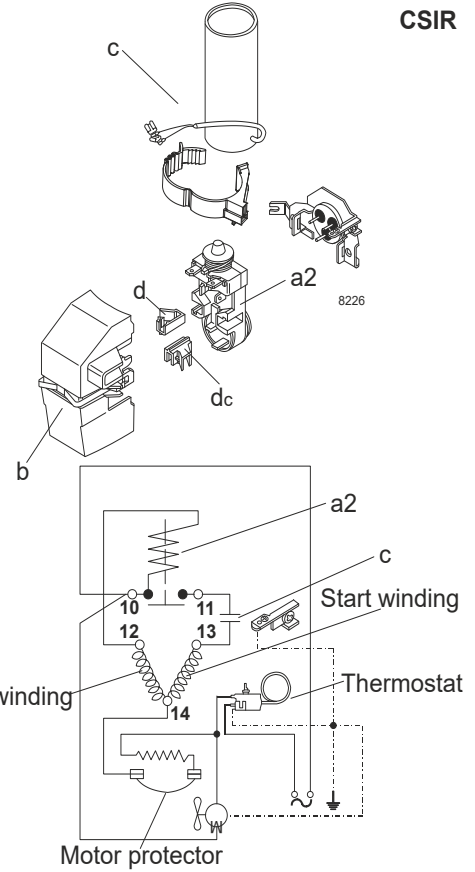

Ambient/ machine room temperatures minimum /maximum

Ambient temperature range: 10 - 43°C / 50 - 110°F

Machine room temperature range: 10 - 48°C / 50 - 119°F

Compressor cooling: fan 3m/s

Operation pressure range

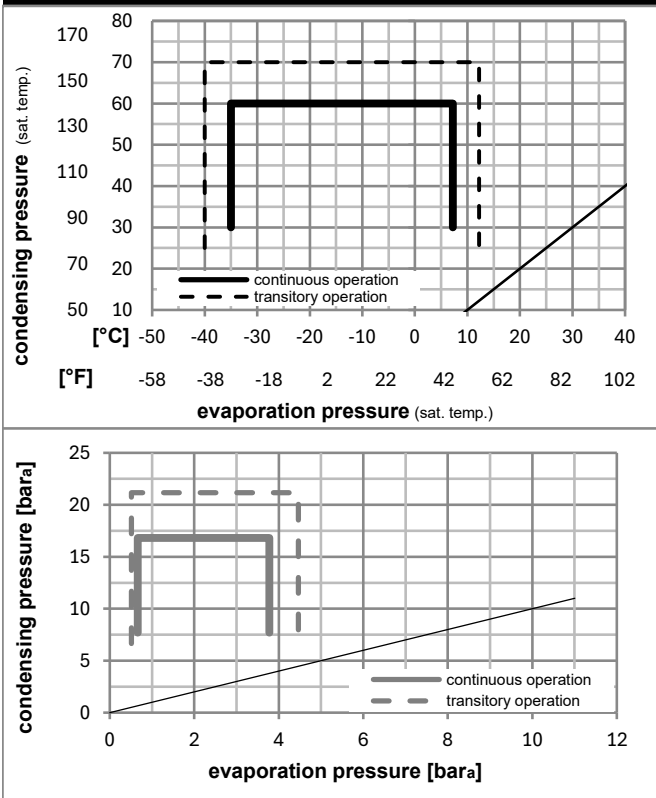

Components

a2	current relay (MRP36AEN-6)	117U4127
c	start capacitor (280µF)	117U5025
b	plastic cover	117U1021
d/dc	cord relief	117U0349

Customer specific model

Model

Designation	NF5.5FX	115-127V/60Hz	Conf. 1	Sales code:	105G5626
-------------	----------------	----------------------	----------------	-------------	-----------------

Optimization + standard conditions

R134a, 115V/60Hz, CSIR, fan 3m/s, UL, EAC

	Evaporating pressure (saturation temperature)				Cooling capacity			COP	EER	P1	Power consumption		ASHRAE LBP	
	pe	pc	RGT	Tliq	[W]	[Btu/h]	[kcal/h]				[W]	[A]		[kg/h]
[°C]	-23	54	32	32	203,9	696	175,5	1,21	4,13	1,04	168,8	2,50	3,96	
[°F]	-10	130	90	90										
[°C]	-25	55	32	55	148,4	507	127,8	0,93	3,19	0,80	158,8	2,45	3,55	cecomaf LBP
[°F]	-13	131	90	131										
[°C]	-35	40	20	40	100,9	345	86,9	0,95	3,23	0,81	106,7	2,26	2,21	EN12900 LBP
[°F]	-31	104	68	104										
[°C]	-7	54	35	46	425,8	1454	366,5	1,67	5,71	1,44	254,7	3,04	9,29	ASHRAE MBP
[°F]	20	130	95	115										
[°C]	-10	55	32	55	330,3	1128	284,3	1,38	4,71	1,19	239,5	2,93	7,99	cecomaf MBP
[°F]	14	131	90	131										
[°C]	-10	45	20	45	375,5	1282	323,1	1,66	5,68	1,43	225,9	2,83	8,79	EN12900 MBP
[°F]	14	113	68	113										

Performance tables

R134a, 115V/60Hz, CSIR, fan 3m/s, UL, EAC

	pe		Cooling capacity			COP	EER		P1	I	m
	[°C]	[°F]	[W]	[Btu/h]	[kcal/h]		[Btu/Wh]	[kcal/Wh]			
[°C / °F]	-35	-31	91,0	311	78,3	0,88	3,00	0,75	103,7	2,22	1,96
cond. pressure	-23	-10	199,5	681	171,7	1,20	4,08	1,03	166,9	2,49	4,33
pc= 45/113	-15	5	308,1	1052	265,1	1,50	5,13	1,29	204,9	2,70	6,71
return gas temp.	-9	15	399,4	1364	343,8	1,75	5,98	1,51	228,2	2,85	8,75
RGT= 32/90	-4	25	508,9	1738	437,9	2,03	6,93	1,75	250,6	3,00	11,20
liquid temp	0	32	597,5	2040	514,2	2,25	7,67	1,93	266,1	3,12	13,21
Tliq= 45/113	7,2	45	791,4	2703	681,1	2,68	9,15	2,31	295,3	3,34	17,68
[°C / °F]	-35	-31	65,9	225	56,8	0,71	2,43	0,61	92,5	2,16	1,57
cond. pressure	-23	-10	164,6	562	141,7	0,98	3,33	0,84	168,7	2,50	3,94
pc= 55/131	-15	5	259,6	887	223,4	1,21	4,13	1,04	214,5	2,77	6,25
return gas temp	-9	15	338,9	1158	291,7	1,40	4,78	1,20	242,1	2,95	8,20
RGT= 32/90	-4	25	433,9	1482	373,4	1,62	5,52	1,39	268,3	3,15	10,56
liquid temp	0	32	510,9	1745	439,7	1,79	6,10	1,54	286,1	3,29	12,50
Tliq= 55/131	7,2	45	680,1	2323	585,3	2,13	7,29	1,84	318,6	3,56	16,82

Customer specific model

Model					
Designation	NF5.5FX	115-127V/60Hz	Conf. 2	Sales code:	105G5626

Configuration

Motorconfiguration	CSIR
Power supply (nominal)	115-127V/60Hz 1~
Refrigerant	R513A
Application	LBP+MBP
Voltage range	95-135V
Starting torque	HST
Approvals	UL
	EAC

Electrical accessories / wiring diagram

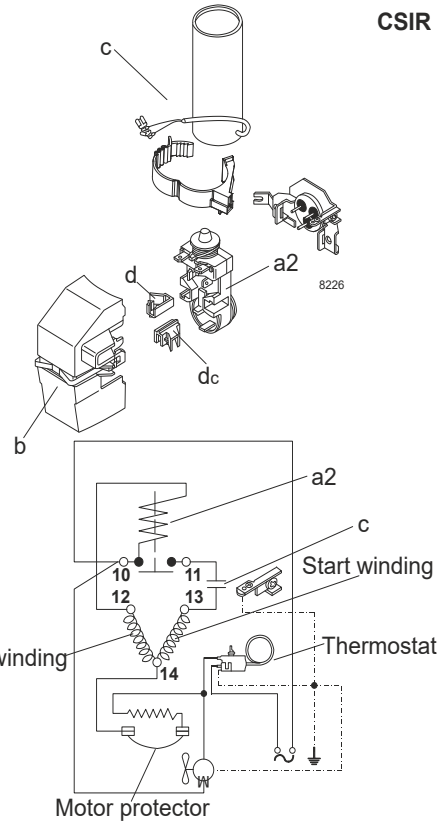

Ambient/ machine room temperatures minimum /maximum

Ambient temperature range:	10 - 43°C / 50 - 110°F
Machine room temperature range:	10 - 48°C / 50 - 119°F
Compressor cooling:	fan 1,5m/s

Operation pressure range

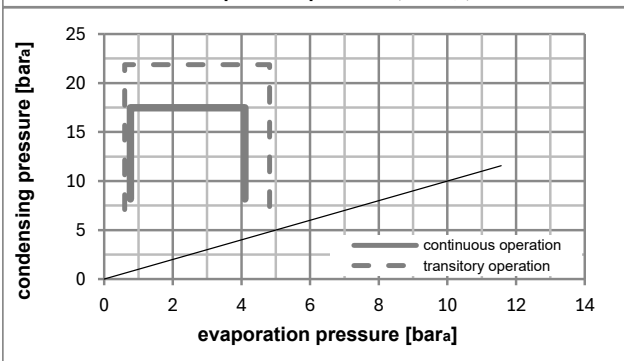
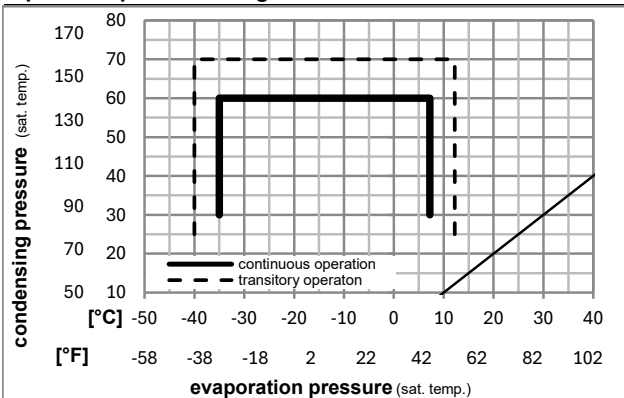

Components

a2	current relay (MRP36AEN-6)	117U4127
c	start capacitor (280μF)	117U5025
b	plastic cover	117U1021
d/dc	cord relief	117U0349

Customer specific model

Model

Designation	NF5.5FX	115-127V/60Hz	Conf. 2	Sales code:	105G5626
-------------	----------------	----------------------	----------------	-------------	-----------------

Optimization + standard conditions

R513A, 115V/60Hz, CSIR, fan 1,5m/s, UL, EAC

		Evaporating pressure (saturation temperature)				Condensing pressure (saturation temperature)			Return gas temp.		Liquid temp.		Cooling capacity			COP	EER	Power consumption		
		pe	pc	RGT	Tliq	[W]	[Btu/h]	[kcal/h]	[W/W]	[Btu/Wh]	[kcal/Wh]	P1	I	m						
[°C]	[°F]	[°C]	[°F]	[°C]	[°F]							[W]	[A]	[kg/h]						
-23	-10	54	130	32	90	32	90	225,3	769	193,9	1,24	4,23	1,06	182,0	3,00	4,85				ASHRAE LBP
-25	-13	55	131	32	90	55	131	159,6	545	137,4	0,93	3,18	0,80	171,7	2,96	4,37				cecomaf LBP
-35	-31	40	104	20	68	40	104	112,9	386	97,2	0,98	3,34	0,84	115,5	2,75	2,79				EN12900 LBP
-7	20	54	130	35	95	46	115	446,9	1526	384,6	1,66	5,67	1,43	269,4	3,45	10,95				ASHRAE MBP
-10	14	55	131	32	90	55	131	342,6	1170	294,9	1,35	4,60	1,16	254,3	3,36	9,47				cecomaf MBP
-10	14	45	113	20	68	45	113	392,5	1340	337,7	1,64	5,60	1,41	239,4	3,28	10,40				EN12900 MBP

Performance tables

R513A, 115V/60Hz, CSIR, fan 1,5m/s, UL, EAC

	pe		Cooling capacity			COP	EER	P1			I	m
	[°C]	[°F]	[W]	[Btu/h]	[kcal/h]	[W/W]	[Btu/Wh]	[kcal/Wh]	[W]	[A]	[kg/h]	
[°C / °F]	-35	-31	102,6	350	88,3	0,91	3,11	0,78	112,7	2,74	2,49	
cond. pressure	-23	-10	216,0	738	185,9	1,20	4,12	1,04	179,3	2,98	5,27	
pc= 45/113	-15	5	327,5	1119	281,9	1,50	5,13	1,29	218,2	3,17	8,03	
return gas temp.	-9	15	420,4	1436	361,8	1,74	5,94	1,50	241,7	3,29	10,34	
RGT= 32/90	-4	25	530,8	1813	456,8	2,01	6,87	1,73	264,0	3,42	13,12	
liquid temp	0	32	619,8	2117	533,4	2,22	7,58	1,91	279,2	3,52	15,37	
Tliq= 45/113	7,2	45	813,3	2778	700,0	2,64	9,02	2,27	307,9	3,70	20,34	
[°C / °F]	-35	-31	74,7	255	64,3	0,74	2,51	0,63	101,5	2,69	2,04	
cond. pressure	-23	-10	176,1	601	151,5	0,97	3,30	0,83	182,0	3,00	4,83	
pc= 55/131	-15	5	272,0	929	234,1	1,19	4,06	1,02	229,0	3,23	7,49	
return gas temp	-9	15	351,2	1199	302,2	1,37	4,67	1,18	257,0	3,38	9,72	
RGT= 32/90	-4	25	445,3	1521	383,2	1,57	5,37	1,35	283,0	3,54	12,38	
liquid temp	0	32	521,2	1780	448,5	1,73	5,92	1,49	300,5	3,65	14,55	
Tliq= 55/131	7,2	45	687,2	2347	591,4	2,07	7,06	1,78	332,3	3,87	19,37	