

Model

Designation	NF6.1FX.2	115-127V/60Hz 1~	Sales code:	105G5638
-------------	------------------	------------------	-------------	-----------------

Compressor design

Oil type	Polyolester	Refrigerant(s)	R134a, R513A, 0
Oil viscosity	32cST	Displacement	6,13cm ³ / 0,37cu.in
Oil quantity	270cm ³ / 9,1fl.oz	Compressors on pallet	80
Refr. charge - tech. limit	400g / 14,1oz		
Free gas volume comp.	2360cm ³ / 79,8fl.oz		
Weight	10kg / 22lbs		
Motor protection	external		
Winding resistance main	2Ω (at 25°C)		
Winding resistance aux	3,1Ω (at 25°C)		
Max. winding temp.	125°C / 257°F		
Max. discharge temp.	130°C / 266°F		



General - Configurations with NF6.1FX.2

	Conf. 1	Conf. 2
Motorconfiguration	CSIR	CSIR
Power supply (nominal)	115V/60Hz	115V/60Hz
Number of phases	1	1
Voltage range	95-135V	95-135V
Approvals	UL	UL
Starting torque	HST	HST
Note	Electrical equipment is included and pre-assembled to compressor.	

Applications with NF6.1FX.2

	Conf. 1	Conf. 2
Refrigerant	R134a	R513A
Application	LBP+MBP	LBP+MBP
System cooling	fan 1,5m/s	fan 1,5m/s
Hot gas defrost	-/-	-/-
Long interval pull down	OK	OK

Electrical data - Configurations with NF6.1FX.2

	Conf. 1	Conf. 2
Starting device type	relay	relay
Run capacitor	-/-	-/-
Start capacitor	280μF	280μF
LRA (locked rotor amps / 4s/ U(N))	22,2A	22,2A
RLA (rated load amps / 1s/ U(N))	3,7A	3,7A
Cut in current (U(N))	22,2A	22,2A

Model

Designation

NF6.1FX.2

115-127V/60Hz 1~

Sales code:

105G5638

Compressor dimensions

Housing	A Height	197mm / 7,76in
	B Height	191mm / 7,52in
	C Length shell	205mm / 8,07in
	D Length w. cover	254mm / 10in
	E Width	166mm / 6,54in

Connectors		Suction	Discharge	Process
		X	Y	Z
Diameter	[mm]	øi 8,11-8,29	øi 6,41-6,59	øi 6,41-6,59
	(i:inside, o:outside) [in]	øi 0,32-0,33	øi 0,25-0,26	øi 0,25-0,26
Material		copper	copper	copper
Horizontal angle	±2°	0°	0°	0°
Vertical angle	±2°	15°	35°	155°
Position l/h/w	[mm]	126/76/78	133/103/54	-107/94/72
	[in]	4,9/3/3,1	5,2/4/2,1	-4,2/3,7/2,8
Straight tube l.	[mm]	12	12	12
	[in]	0,5	0,5	0,5

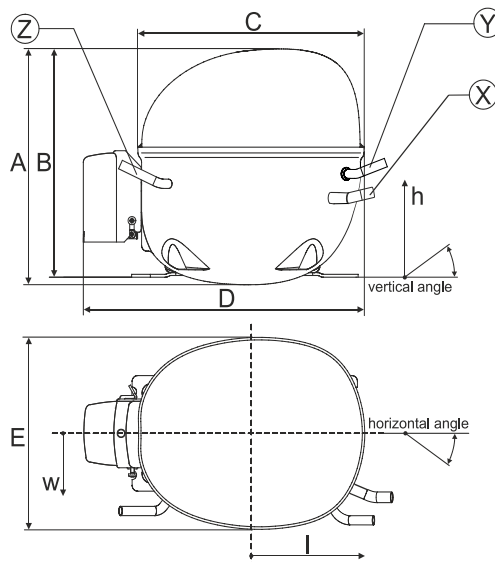

Compressor fixation



Bolt joint



Snap-on

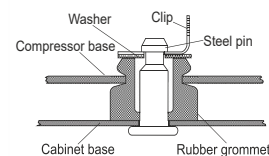

Mounting accessories

	one comp.	multi pack
Bolt joint M6 ø16mm	118-1917	118-1918
Bolt joint ø1/4" ø16mm	118-1946	
Bolt joint ø1/4" ø19mm	118-1949	
Snap-on ø7,3 ø16mm	118-1947	118-1919

Application notes

Provision for PE Grounding is located at the PE Stamp on the compressor

Model

Designation	NF6.1FX.2	115V/60Hz	Conf. 1	Sales code:	105G5638
-------------	------------------	------------------	----------------	-------------	-----------------

Configuration

Motorconfiguration	CSIR
Power supply (nominal)	115V/60Hz 1~
Refrigerant	R134a
Application	LBP+MBP
Voltage range	95-135V
Starting torque	HST
Approvals	UL

Electrical accessories / wiring diagram

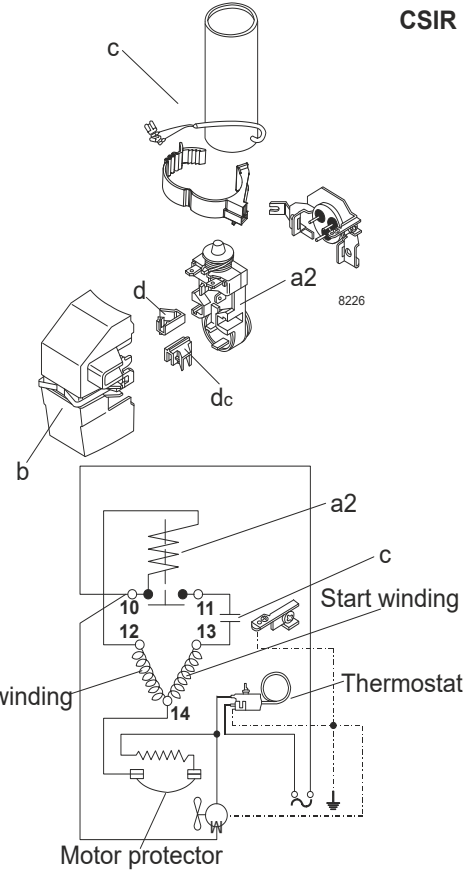

Ambient/ machine room temperatures minimum /maximum

Ambient temperature range: 10 - 43°C / 50 - 110°F

Machine room temperature range: 10 - 48°C / 50 - 119°F

Compressor cooling: fan 1,5m/s

Operation pressure range

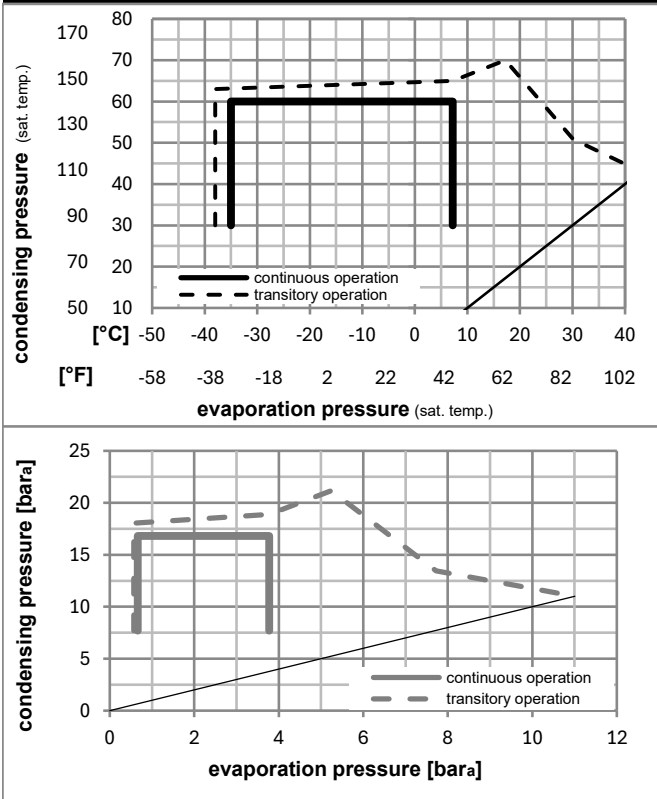

Components (already pre-assembled)

a2	current relay (MRP36AEN-6)	117U4127
c	start capacitor (280µF)	117U5025
b	plastic cover	117U1021
d/dc	cord relief	117U0349
d/dc	cord relief	117U0349

Alternative comp. (already pre-assembled)

a2	current relay (MRP36AEN-6)	117U4157
c	start capacitor (280µF)	117U5074

Model

Designation	NF6.1FX.2	115V/60Hz	Conf. 1	Sales code:	105G5638
-------------	------------------	------------------	----------------	-------------	-----------------

Optimization + standard conditions

R134a, 115V/60Hz, CSIR, fan 1,5m/s, UL

	Evaporating pressure (saturation temperature)				Cooling capacity			COP	EER	P1	Power consumption		ASHRAE LBP	
	pe	pc	RGT	Tliq	[W]	[Btu/h]	[kcal/h]				I	m		
	[°C]	[°F]	[°C]	[°F]	[W]	[Btu/h]	[kcal/h]	[W/W]	[Btu/Wh]	[kcal/Wh]	[W]	[A]	[kg/h]	
	-23	54	32	32	211,3	721	181,8	1,19	4,06	1,02	177,6	2,66	4,10	ASHRAE LBP
	-10	130	90	90										
	-25	55	32	55	152,8	522	131,5	0,90	3,08	0,78	169,4	2,62	3,65	cecomaf LBP
	-13	131	90	131										
	-35	40	20	40	99,9	341	86,0	0,76	2,59	0,65	131,6	2,48	2,19	EN12900 LBP
	-31	104	68	104										
	-23	49	4,4	49	177,9	608	153,1	1,00	3,42	0,86	177,9	2,64	4,70	ARI540 LBP
	-10	120	40	120										
	-23	41	32	32	242,6	828	208,8	1,38	4,70	1,19	176,1	2,62	4,71	AHAM LBP
	-10	105	90	90										
	-35	45	32	45	90,9	310	78,2	0,71	2,42	0,61	128,1	2,47	1,96	opt
	-31	113	90	113										

Performance tables

R134a, 115V/60Hz, CSIR, fan 1,5m/s, UL

	pe		Cooling capacity			COP	EER		P1	I	m
	[°C]	[°F]	[W]	[Btu/h]	[kcal/h]		[Btu/Wh]	[kcal/Wh]			
[°C / °F]	-35	-31	90,9	310	78,2	0,71	2,42	0,61	128,1	2,47	1,96
cond. pressure	-23	-10	209,5	716	180,3	1,18	4,03	1,02	177,4	2,64	4,54
pc= 45/113	-15	5	326,8	1116	281,2	1,56	5,34	1,34	209,2	2,80	7,12
return gas temp.	-9	15	422,9	1444	363,9	1,83	6,27	1,58	230,5	2,93	9,26
RGT= 32/90	-4	25	535,2	1828	460,6	2,12	7,23	1,82	252,9	3,08	11,78
liquid temp	0	32	624,2	2132	537,2	2,31	7,90	1,99	269,7	3,20	13,80
Tliq= 45/113	7,2	45	814,4	2781	700,9	2,67	9,13	2,30	304,6	3,43	18,19
[°C / °F]	-35	-31	69,1	236	59,4	0,59	2,02	0,51	116,9	2,44	1,64
cond. pressure	-23	-10	170,2	581	146,5	0,96	3,28	0,83	177,5	2,66	4,07
pc= 55/131	-15	5	274,3	937	236,1	1,27	4,32	1,09	216,7	2,86	6,60
return gas temp	-9	15	361,3	1234	311,0	1,49	5,09	1,28	242,6	3,01	8,74
RGT= 32/90	-4	25	464,3	1586	399,6	1,72	5,89	1,48	269,3	3,19	11,30
liquid temp	0	32	546,6	1867	470,4	1,89	6,46	1,63	289,0	3,32	13,37
Tliq= 55/131	7,2	45	724,0	2473	623,1	2,20	7,52	1,89	328,9	3,58	17,91

Model

Designation	NF6.1FX.2	115V/60Hz	Conf. 2	Sales code:	105G5638
-------------	------------------	------------------	----------------	-------------	-----------------

Configuration

Motorconfiguration	CSIR
Power supply (nominal)	115V/60Hz 1~
Refrigerant	R513A
Application	LBP+MBP
Voltage range	95-135V
Starting torque	HST
Approvals	UL

Electrical accessories / wiring diagram

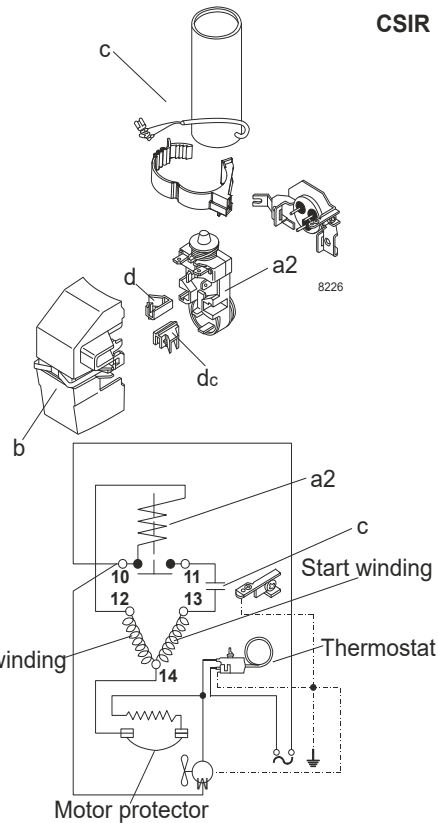

Ambient/ machine room temperatures minimum /maximum

Ambient temperature range: 10 - 43°C / 50 - 110°F

Machine room temperature range: 10 - 48°C / 50 - 119°F

Compressor cooling: fan 1,5m/s

Operation pressure range

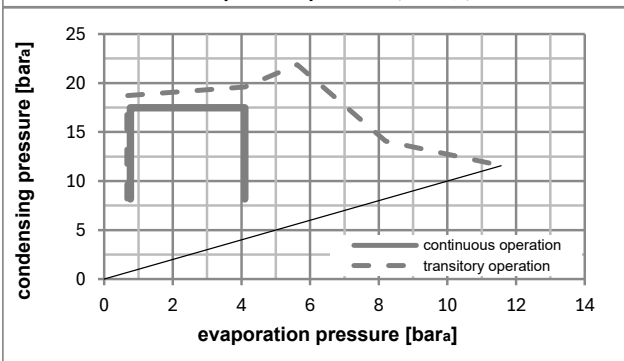
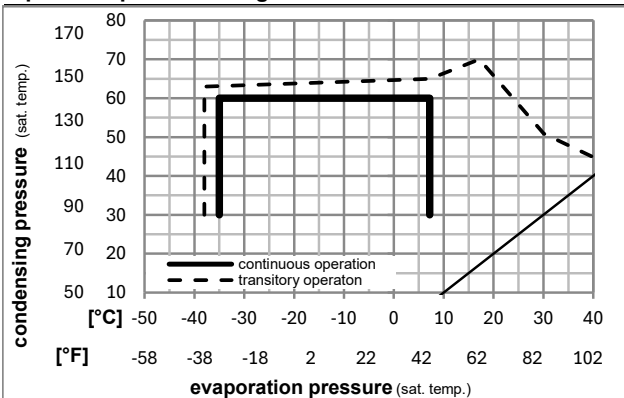

Components (already pre-assembled)

a2	current relay (MRP36AEN-6)	117U4127
c	start capacitor (280μF)	117U5025
b	plastic cover	117U1021
d/dc	cord relief	117U0349
d/dc	cord relief	117U0349

Alternative comp. (already pre-assembled)

a2	current relay (MRP36AEN-6)	117U4157
c	start capacitor (280μF)	117U5074

