

Model

Designation	NF7.3FX.2	115-127V/60Hz 1~	Sales code:	105G5722
-------------	------------------	------------------	-------------	-----------------

Compressor design

Oil type	Polyolester	Refrigerant(s)	R134a, R513A, 0
Oil viscosity	32cST	Displacement	7,27cm ³ / 0,44cu.in
Oil quantity	268cm ³ / 9,1fl.oz	Compressors on pallet	80
Refr. charge - tech. limit	400g / 14,1oz		
Free gas volume comp.	2360cm ³ / 79,8fl.oz		
Weight	10kg / 22lbs		
Motor protection	external		
Winding resistance main	1,6Ω (at 25°C)		
Winding resistance aux	6,2Ω (at 25°C)		
Max. winding temp.	125°C / 257°F		
Max. discharge temp.	130°C / 266°F		



General - Configurations with NF7.3FX.2

	Conf. 1	Conf. 2
Motorconfiguration	CSIR	CSIR
Power supply (nominal)	115-127V/60Hz	115-127V/60Hz
Number of phases	1	1
Voltage range	95-135V	95-135V
Approvals	UL, EAC	UL, EAC
Starting torque	HST	HST
Note	- / -	

Applications with NF7.3FX.2

	Conf. 1	Conf. 2
Refrigerant	R134a	R513A
Application	LBP+MBP	LBP+MBP
System cooling	fan 1,5m/s	fan 1,5m/s
Hot gas defrost	-/-	-/-
Long interval pull down	OK	OK

Electrical data - Configurations with NF7.3FX.2

	Conf. 1	Conf. 2
Starting device type	relay	relay
Run capacitor	-/-	-/-
Start capacitor	280μF	280μF
LRA (locked rotor amps / 4s/ U(N))		
RLA (rated load amps / 1s/ U(N))		
Cut in current (U(N))		

Model

Designation

NF7.3FX.2

115-127V/60Hz 1~

Sales code:

105G5722

Compressor dimensions

Housing	A Height	197mm / 7,76in
	B Height	191mm / 7,52in
	C Length shell	205mm / 8,07in
	D Length w. cover	254mm / 10in
	E Width	166mm / 6,54in

Connectors		Suction	Discharge	Process
		X	Y	Z
Diameter	[mm]	øi 8,11-8,29	øi 6,41-6,59	øi 6,41-6,59
	(i:inside, o:outside) [in]	øi 0,32-0,33	øi 0,25-0,26	øi 0,25-0,26
Material		copper	copper	copper
Horizontal angle	±2°	0°	0°	0°
Vertical angle	±2°	15°	35°	155°
Position l/h/w	[mm]	126/76/78	133/103/54	-107/94/72
	[in]	4,9/3/3,1	5,2/4/2,1	-4,2/3,7/2,8
Straight tube l.	[mm]	12	12	12
	[in]	0,5	0,5	0,5

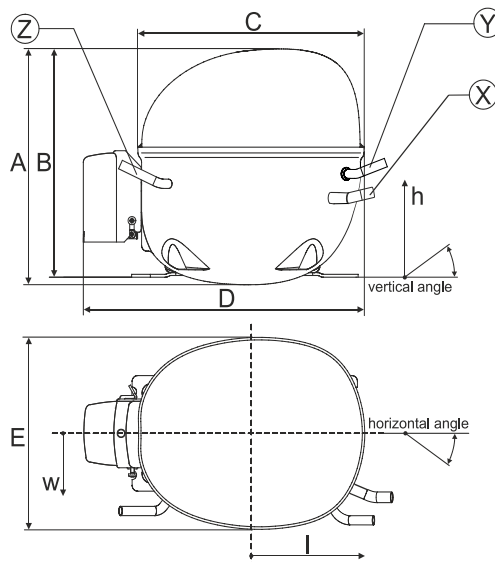

Compressor fixation



Bolt joint



Snap-on

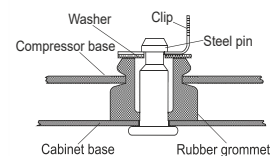

Mounting accessories

	one comp.	multi pack
Bolt joint M6 ø16mm	118-1917	118-1918
Bolt joint ø1/4" ø16mm	118-1946	
Bolt joint ø1/4" ø19mm	118-1949	
Snap-on ø7,3 ø16mm	118-1947	118-1919

Application notes

Provision for PE Grounding is located at the PE Stamp on the compressor

Model

Designation	NF7.3FX.2	115-127V/60Hz	Conf. 1	Sales code:	105G5722
-------------	------------------	----------------------	---------	-------------	-----------------

Configuration

Motorconfiguration	CSIR
Power supply (nominal)	115-127V/60Hz 1~
Refrigerant	R134a
Application	LBP+MBP
Voltage range	95-135V
Starting torque	HST
Approvals	UL
	EAC

Electrical accessories / wiring diagram

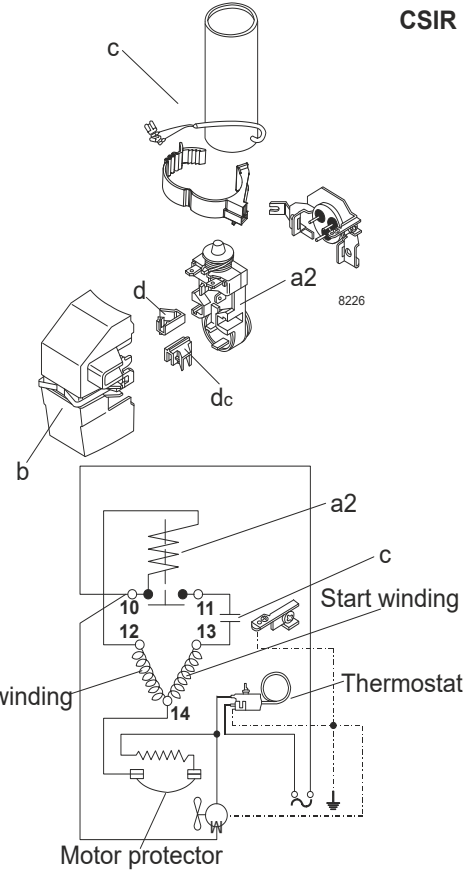

Ambient/ machine room temperatures minimum /maximum

Ambient temperature range: 10 - 43°C / 50 - 110°F

Machine room temperature range: 10 - 48°C / 50 - 119°F

Compressor cooling: fan 1,5m/s

Operation pressure range

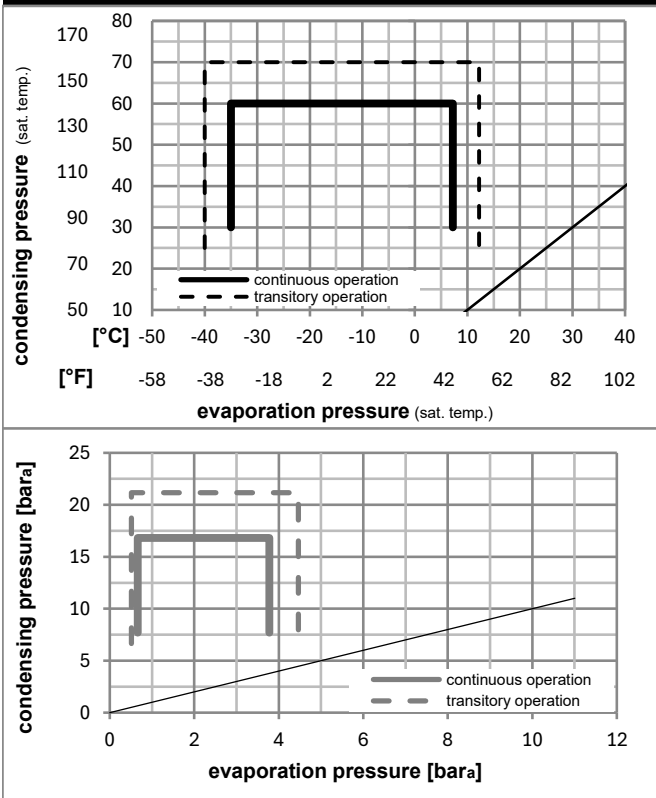

Components

a2	relay (protector: TI MRP30AEN-6)	117U4061
c	start capacitor (280µF)	117U5025
b	plastic cover	117U1021
d/dc	cord relief	117U0349
d/dc	cord relief	117U0349

Alternative components

b	assy. terminal board 6.3mm	117U1024
---	----------------------------	----------

Model

Designation	NF7.3FX.2	115-127V/60Hz	Conf. 1	Sales code:	105G5722
-------------	------------------	----------------------	----------------	-------------	-----------------

Optimization + standard conditions

R134a, 115V/60Hz, CSIR, fan 1,5m/s, UL, EAC

	Evaporating pressure (saturation temperature)				Cooling capacity			COP	EER	P1	Power consumption		ASHRAE LBP	
	pe	pc	RGT	Tliq	[W]	[Btu/h]	[kcal/h]				I	m		
	[°C]	[°F]	[°C]	[°F]	[W]	[Btu/h]	[kcal/h]	[W/W]	[Btu/Wh]	[kcal/Wh]	[W]	[A]	[kg/h]	
	-23	54	32	32	261,5	893	225,1	1,16	3,95	1,00	226,0	3,57	5,08	ASHRAE LBP
	-10	130	90	90										
	-25	55	32	55	190,3	650	163,8	0,88	3,01	0,76	215,8	3,53	4,55	cecomaf LBP
	-13	131	90	131										
	-35	40	20	40	127,5	436	109,8	0,76	2,58	0,65	168,9	3,35	2,80	EN12900 LBP
	-31	104	68	104										
	-7	54	35	46	548,4	1873	472,0	1,70	5,82	1,47	322,1	4,12	11,97	ASHRAE MBP
	20	130	95	115										
	-10	55	32	55	425,5	1453	366,2	1,40	4,79	1,21	303,3	4,00	10,29	cecomaf MBP
	14	131	90	131										
	-10	45	20	45	479,2	1637	412,4	1,66	5,67	1,43	288,9	3,90	11,22	EN12900 MBP
	14	113	68	113										

Performance tables

R134a, 115V/60Hz, CSIR, fan 1,5m/s, UL, EAC

	pe		Cooling capacity			COP	EER		P1	I	m
	[°C]	[°F]	[W]	[Btu/h]	[kcal/h]		[Btu/Wh]	[kcal/Wh]			
[°C / °F]	-35	-31	117,1	400	100,8	0,71	2,43	0,61	164,5	3,34	2,53
cond. pressure	-23	-10	257,3	879	221,4	1,14	3,89	0,98	225,7	3,54	5,58
pc= 45/113	-15	5	395,8	1352	340,6	1,49	5,10	1,28	265,1	3,75	8,63
return gas temp.	-9	15	509,4	1740	438,4	1,75	5,97	1,50	291,6	3,92	11,15
RGT= 32/90	-4	25	642,0	2193	552,5	2,01	6,87	1,73	319,4	4,10	14,14
liquid temp	0	32	747,2	2552	643,1	2,20	7,50	1,89	340,2	4,25	16,52
Tliq= 45/113	7,2	45	971,9	3319	836,4	2,53	8,66	2,18	383,5	4,54	21,71
[°C / °F]	-35	-31	91,4	312	78,6	0,61	2,07	0,52	150,7	3,30	2,17
cond. pressure	-23	-10	210,9	720	181,5	0,93	3,19	0,80	225,8	3,57	5,05
pc= 55/131	-15	5	333,8	1140	287,3	1,22	4,15	1,05	274,4	3,82	8,04
return gas temp	-9	15	436,6	1491	375,8	1,42	4,86	1,23	306,6	4,02	10,56
RGT= 32/90	-4	25	558,3	1907	480,5	1,64	5,61	1,41	339,8	4,23	13,59
liquid temp	0	32	655,6	2239	564,2	1,80	6,15	1,55	364,2	4,40	16,04
Tliq= 55/131	7,2	45	865,1	2955	744,5	2,09	7,14	1,80	413,7	4,73	21,40

Model

Designation	NF7.3FX.2	115-127V/60Hz	Conf. 2	Sales code:	105G5722
-------------	------------------	----------------------	----------------	-------------	-----------------

Configuration

Motorconfiguration	CSIR
Power supply (nominal)	115-127V/60Hz 1~
Refrigerant	R513A
Application	LBP+MBP
Voltage range	95-135V
Starting torque	HST
Approvals	UL
	EAC

Electrical accessories / wiring diagram

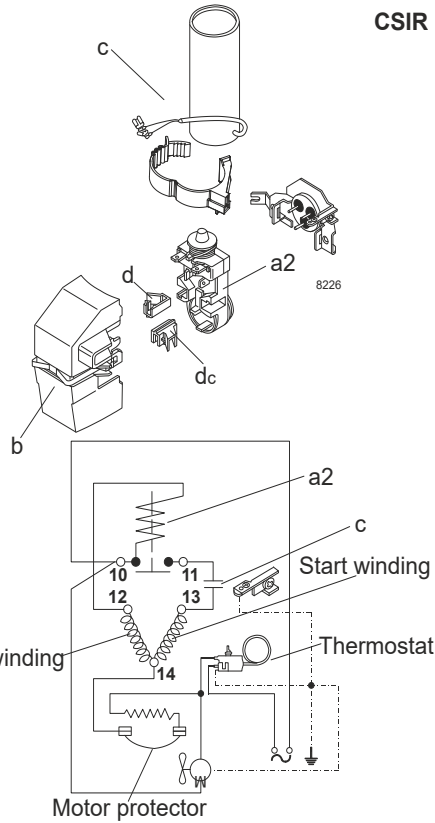

Ambient/ machine room temperatures minimum /maximum

Ambient temperature range:	10 - 43°C / 50 - 110°F
Machine room temperature range:	10 - 48°C / 50 - 119°F
Compressor cooling:	fan 1,5m/s

Operation pressure range

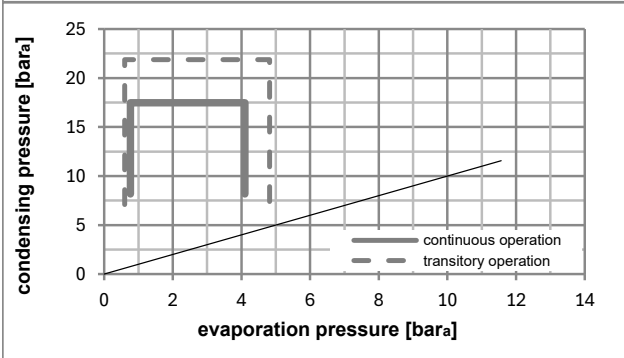
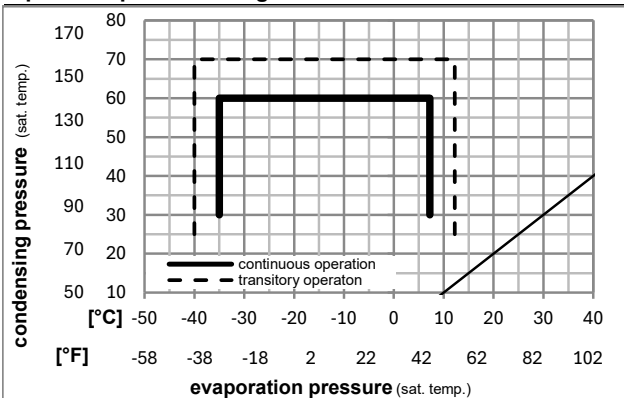

Components

a2	relay (protector: TI MRP30AEN-6)	117U4061
c	start capacitor (280µF)	117U5025
b	plastic cover	117U1021
d/dc	cord relief	117U0349
d/dc	cord relief	117U0349

Alternative components

b	assy. terminal board 6.3mm	117U1024
---	----------------------------	----------

Model

Designation	NF7.3FX.2	115-127V/60Hz	Conf. 2	Sales code:	105G5722
-------------	------------------	----------------------	----------------	-------------	-----------------

Optimization + standard conditions

R513A, 115V/60Hz, CSIR, fan 1,5m/s, UL, EAC

		Evaporating pressure (saturation temperature)				Condensing pressure (saturation temperature)			Return gas temp.		Liquid temp.		Cooling capacity			COP	EER	Power consumption		
		pe	pc	RGT	Tliq	[W]	[Btu/h]	[kcal/h]	[W/W]	[Btu/Wh]	[kcal/Wh]	P1	I	m						
[°C]	[°F]	[°C]	[°F]	[°C]	[°F]							[W]	[A]	[kg/h]						
-23	-10	54	130	32	90	289,1	987	248,8	1,18	4,04	1,02	244,1	3,88	6,22						ASHRAE LBP
-25	-13	55	131	32	90	204,8	699	176,3	0,88	2,99	0,75	233,8	3,81	5,61						cecomaf LBP
-35	-31	40	104	20	68	142,4	486	122,6	0,78	2,66	0,67	182,9	3,68	3,52						EN12900 LBP
-7	20	54	130	35	95	575,5	1965	495,3	1,69	5,77	1,45	340,5	4,40	14,10						ASHRAE MBP
-10	14	55	131	32	90	441,3	1507	379,7	1,37	4,68	1,18	322,0	4,30	12,20						cecomaf MBP
-10	14	45	113	20	68	500,9	1711	431,0	1,64	5,59	1,41	305,8	4,20	13,28						EN12900 MBP

Performance tables

R513A, 115V/60Hz, CSIR, fan 1,5m/s, UL, EAC

	pe		Cooling capacity			COP	EER	P1			I	m
	[°C]	[°F]	[W]	[Btu/h]	[kcal/h]	[W/W]	[Btu/Wh]	[kcal/Wh]	[W]	[A]	[kg/h]	
[°C / °F]	-35	-31	131,7	450	113,4	0,74	2,52	0,64	178,5	3,62	3,20	
cond. pressure	-23	-10	278,6	951	239,8	1,15	3,92	0,99	242,4	3,92	6,80	
pc= 45/113	-15	5	420,8	1437	362,1	1,49	5,09	1,28	282,2	4,09	10,31	
return gas temp.	-9	15	536,1	1831	461,3	1,74	5,93	1,50	308,5	4,21	13,19	
RGT= 32/90	-4	25	669,7	2287	576,3	1,99	6,81	1,72	336,0	4,35	16,55	
liquid temp	0	32	775,0	2647	667,0	2,17	7,42	1,87	356,7	4,47	19,22	
Tliq= 45/113	7,2	45	998,7	3411	859,5	2,50	8,53	2,15	399,9	4,74	24,98	
[°C / °F]	-35	-31	102,6	351	88,3	0,62	2,12	0,53	165,6	3,39	2,80	
cond. pressure	-23	-10	225,7	771	194,3	0,92	3,16	0,80	244,1	3,87	6,19	
pc= 55/131	-15	5	349,7	1194	301,0	1,19	4,07	1,03	293,2	4,15	9,63	
return gas temp	-9	15	452,3	1545	389,2	1,39	4,75	1,20	325,2	4,32	12,51	
RGT= 32/90	-4	25	572,8	1956	492,9	1,60	5,46	1,38	358,1	4,50	15,93	
liquid temp	0	32	668,7	2284	575,4	1,75	5,97	1,51	382,3	4,65	18,67	
Tliq= 55/131	7,2	45	874,1	2985	752,3	2,03	6,92	1,74	431,5	4,95	24,64	