

Model

Designation	NF7CLX	115-127V/60Hz 1~	Sales code:	105F1728
-------------	---------------	------------------	-------------	-----------------

Compressor design

Oil type	Polyolester	Refrigerant(s)	R404A, R507
Oil viscosity	32cST	Displacement	7,27cm ³ / 0,44cu.in
Oil quantity	298cm ³ / 10,1fl.oz	Compressors on pallet	80
Refr. charge - tech. limit	400g / 14,1oz		
Free gas volume comp.	2280cm ³ / 77,1fl.oz		
Weight	10kg / 22lbs		
Motor protection	external		
Winding resistance main	1,62Ω (at 25°C)		
Winding resistance aux	4,9Ω (at 25°C)		
Max. winding temp.	125°C / 257°F		
Max. discharge temp.	130°C / 266°F		



General - Configurations with NF7CLX

	Conf. 1	Conf. 2
Motorconfiguration	CSIR	CSIR
Power supply (nominal)	115V/60Hz	115V/60Hz
Number of phases	1	1
Voltage range	95-135V	95-135V
Approvals	UL, CCC	UL, CCC
Starting torque	HST	HST
Note	- / -	

Applications with NF7CLX

	Conf. 1	Conf. 2
Refrigerant	R404A	R404A
Application	LBP+MBP	LBP+MBP
System cooling	fan 3m/s	fan 3m/s
Hot gas defrost	- / -	- / -
Long interval pull down	OK	OK

Electrical data - Configurations with NF7CLX

	Conf. 1	Conf. 2
Starting device type	relay	relay
Run capacitor	- / -	- / -
Start capacitor	320μF	320μF
LRA (locked rotor amps / 4s)	30,8A	30,8A
RLA (rated load amps / 1s)	4,9A	4,9A
Cut in current	30,8A	30,8A

Model

Designation

NF7CLX

115-127V/60Hz 1~

Sales code:

105F1728

Compressor dimensions

Housing	A Height	197mm / 7,76in
	B Height	191mm / 7,52in
	C Length shell	205mm / 8,07in
	D Length w. cover	254mm / 10in
	E Width	166mm / 6,54in

Connectors		Suction	Discharge	Process
		X	Y	Z
Diameter	[mm]	øi 9,61-9,79	øi 6,41-6,59	øi 6,41-6,59
	(i:inside, o:outside) [in]	øi 0,38-0,39	øi 0,25-0,26	øi 0,25-0,26
Material		copper	copper	copper
Horizontal angle	±2°	0°	0°	0°
Vertical angle	±2°	15°	35°	155°
Position l/h/w	[mm]	126/76/78	133/103/54	-107/94/72
	[in]	4,9/3/3,1	5,2/4/2,1	-4,2/3,7/2,8
Straight tube l.	[mm]	12	12	12
	[in]	0,5	0,5	0,5

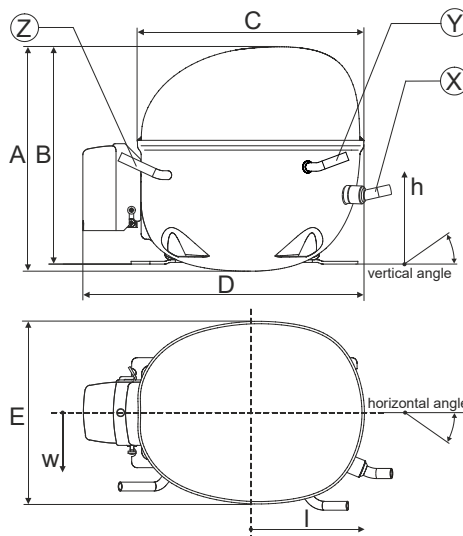

Compressor fixation

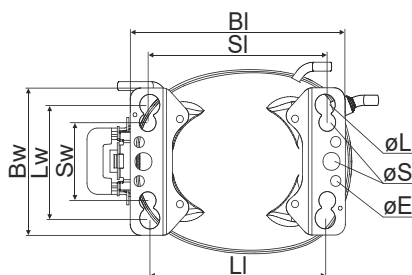

Baseplate	[mm]	[inch]
BI	204	8.03
BW	132	5.2
øE	ø 9.7	ø 0.38
Large holes	[mm]	[inch]
LI	165	6.5
Lw	101.6	4
øL	ø 19	ø 0.75
Small holes	[mm]	[inch]
SI	170	6.7
Sw	70	2.76
øS	ø 16	ø 0.63

Bolt joint

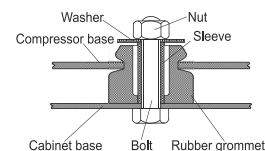

Snap-on

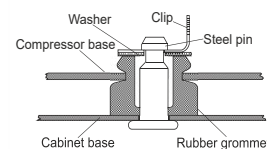

Mounting accessories

	one comp.	multi pack
Bolt joint M6 ø16mm	118-1917	118-1918
Bolt joint ø1/4" ø16mm	118-1946	
Bolt joint ø1/4" ø19mm	118-1949	
Snap-on ø7,3 ø16mm	118-1947	118-1919

Application notes

LRA value on compressor label and datasheet may differ due to different test conditions for UL approval.

Model

Designation	NF7CLX	115V/60Hz	Conf. 1	Sales code:	105F1728
-------------	---------------	------------------	----------------	-------------	-----------------

Configuration

Motorconfiguration	CSIR
Power supply (nominal)	115V/60Hz 1~
Refrigerant	R404A
Application	LBP+MBP
Voltage range	95-135V
Starting torque	HST
Approvals	UL
	CCC

Electrical accessories / wiring diagram

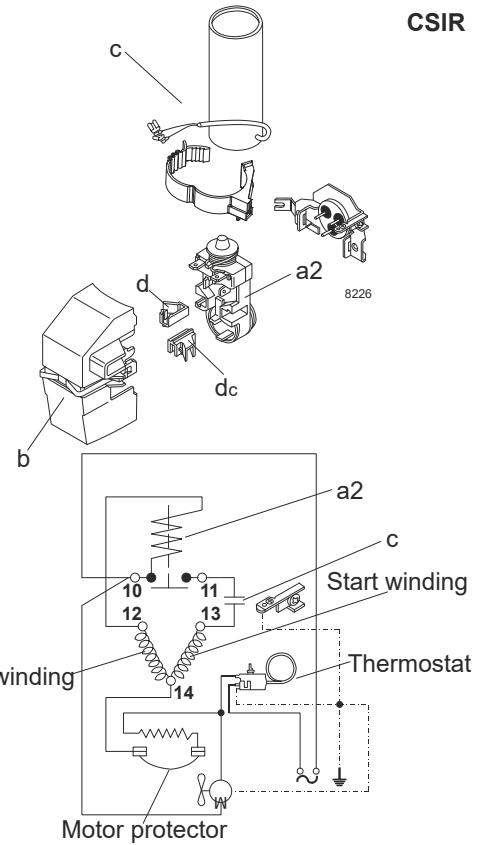

Ambient temperatures / system cooling

Ambient temperature min.:	10°C / 50°F
Ambient temperature max.:	43°C / 110°F

System cooling (n/a: outside limits)			
T ambient	LBP	MBP	HBP
32°C / 90°F	fan 3m/s	fan 3m/s	n/a
38°C / 100°F	fan 3m/s	fan 3m/s	n/a
43°C / 110°F	fan 3m/s	fan 3m/s	n/a

Operation pressure range

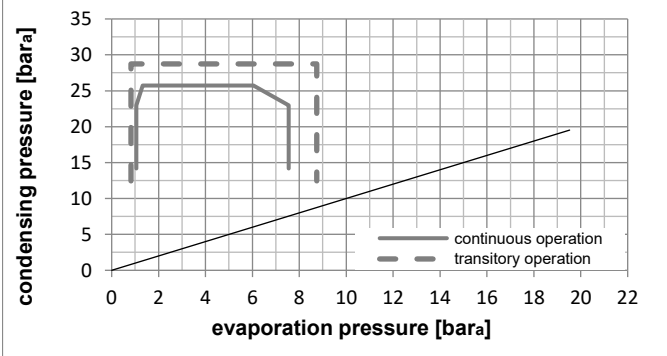
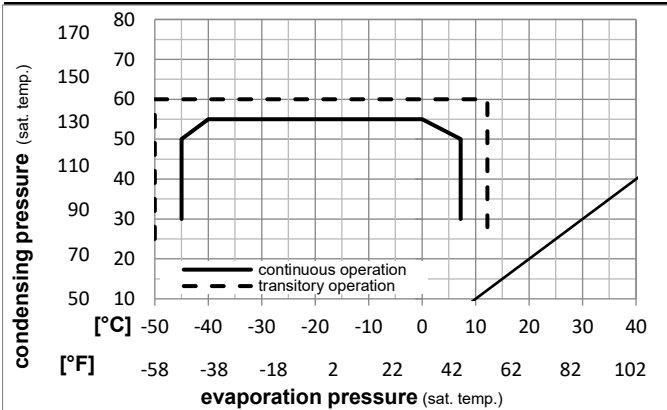

Components

a2	current relay (MRT22AFZ-6)	117U4129
c	start capacitor (320µF)	117U5022
b	plastic cover	117U1021
d/dc	cord relief	117U0349
d/dc	cord relief	117U0349

Model

Designation	NF7CLX	115V/60Hz	Conf. 1	Sales code:	105F1728
-------------	---------------	------------------	----------------	-------------	-----------------

Optimization + standard conditions

R404A, 115V/60Hz, CSIR, fan 3m/s, UL, CCC

	Evaporating pressure (saturation temperature)				Condensing pressure (saturation temperature)			Return gas temp.	Liquid temp.	Cooling capacity	COP	EER	Power consumption			ASHRAE LBP
	pe	pc	RGT	Tliq	[W]	[Btu/h]	[kcal/h]						P1	I	Ref. mass flow	
	[°C]	[°F]	[°C]	[°F]	[W]	[Btu/h]	[kcal/h]	[W/W]	[Btu/Wh]	[kcal/Wh]	[W]	[A]	[kg/h]			
	-23	54	32	32	451,3	1541	388,4	1,23	4,19	1,06	367,7	4,53	10,52	ASHRAE LBP		
	-10	130	90	90												
	-25	55	32	55	305,5	1043	262,9	0,87	2,95	0,74	353,1	4,44	9,55	cecomaf LBP		
	-13	131	90	131												
	-35	40	20	40	248,1	847	213,5	0,93	3,19	0,80	266,0	3,90	6,74	EN12900 LBP		
	-31	104	68	104												
	-23	49	4,4	49	340,3	1162	292,9	0,94	3,20	0,81	362,8	4,46	12,05	ARI540 LBP		
	-10	120	40	120												
	-23	41	32	32	512,7	1751	441,2	1,46	4,98	1,26	351,5	4,37	11,95	AHAM LBP		
	-10	105	90	90												
	-35	45	32	45	230,4	787	198,3	0,86	2,95	0,74	267,1	3,91	6,16	opt		
	-31	113	90	113												

Performance tables

R404A, 115V/60Hz, CSIR, fan 3m/s, UL, CCC

	pe		Cooling capacity			COP	EER	P1	I	m	
	[°C]	[°F]	[W]	[Btu/h]	[kcal/h]	[W/W]	[Btu/Wh]	[kcal/Wh]	[W]	[A]	[kg/h]
[°C / °F]	-45	-49	111,0	379	95,5	0,59	2,00	0,50	189,4	3,64	2,95
cond. pressure	-34	-30	238,3	814	205,1	0,88	3,00	0,76	271,4	3,93	6,37
pc= 45/113	-23	-10	429,9	1468	370,0	1,20	4,10	1,03	358,2	4,42	11,62
return gas temp.	-15	5	623,2	2128	536,4	1,46	4,98	1,25	427,8	4,91	17,02
RGT= 32/90	-4	25	961,8	3285	827,7	1,81	6,17	1,56	532,2	5,74	26,80
liquid temp	0	32	1105,1	3774	951,1	1,93	6,59	1,66	572,9	6,07	31,07
Tliq= 45/113	7,2	45	1409,4	4813	1213,0	2,15	7,34	1,85	656,1	6,76	40,42
[°C / °F]	-45	-49	70,3	240	60,5	0,40	1,37	0,34	175,3	3,60	2,16
cond. pressure	-34	-30	174,3	595	150,0	0,65	2,21	0,56	269,5	3,96	5,39
pc= 55/131	-23	-10	333,3	1138	286,8	0,91	3,09	0,78	368,2	4,53	10,44
return gas temp	-15	5	496,7	1696	427,5	1,11	3,80	0,96	446,0	5,09	15,75
RGT= 32/90	-4	25	788,1	2692	678,3	1,41	4,80	1,21	560,4	6,00	25,58
liquid temp	0	32	913,0	3118	785,7	1,51	5,16	1,30	604,5	6,36	29,94
Tliq= 55/131	7,2	45	1180,3	4031	1015,7	1,70	5,81	1,46	693,4	7,09	39,61

Model

Designation	NF7CLX	115V/60Hz	Conf. 2	Sales code:	105F1728
-------------	---------------	------------------	----------------	-------------	-----------------

Configuration

Motorconfiguration	CSIR
Power supply (nominal)	115V/60Hz 1~
Refrigerant	R404A
Application	LBP+MBP
Voltage range	95-135V
Starting torque	HST
Approvals	UL CCC

Electrical accessories / wiring diagram

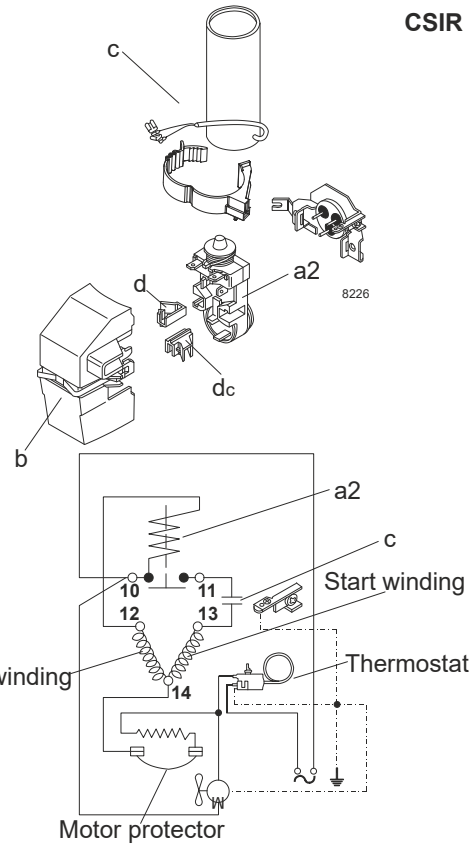

Ambient temperatures / system cooling

Ambient temperature min.:	10°C / 50°F
Ambient temperature max.:	43°C / 110°F

System cooling (n/a: outside limits)			
T ambient	LBP	MBP	HBP
32°C / 90°F	fan 3m/s	fan 3m/s	n/a
38°C / 100°F	fan 3m/s	fan 3m/s	n/a
43°C / 110°F	fan 3m/s	fan 3m/s	n/a

Operation pressure range

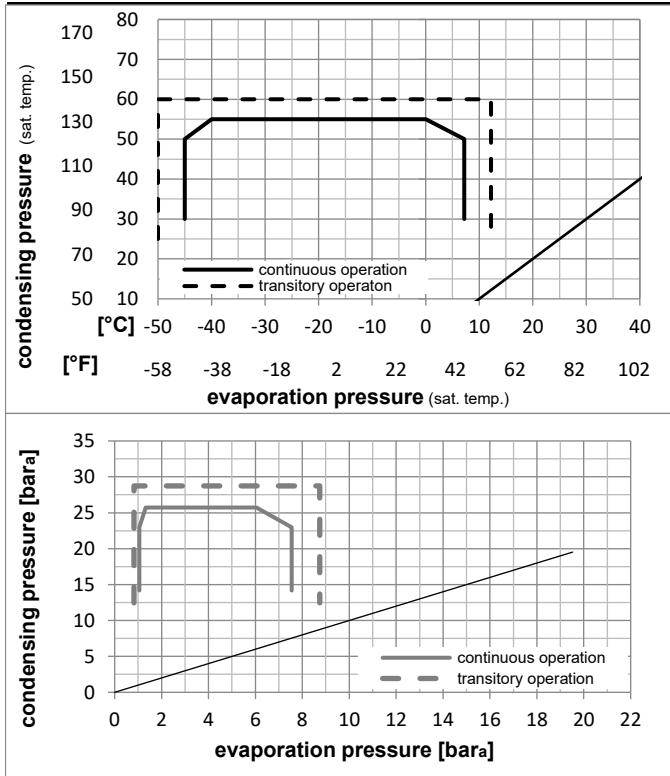

Components

a2	current relay (MRT22AFZ-6)	117U4129
c	start capacitor (320µF)	117U5022
b	assy. terminal board 6.3mm	117U1024

Model

Designation	NF7CLX	115V/60Hz	Conf. 2	Sales code:	105F1728
-------------	---------------	------------------	----------------	-------------	-----------------

Optimization + standard conditions

R404A, 115V/60Hz, CSIR, fan 3m/s, UL, CCC

		Evaporating pressure (saturation temperature)				Condensing pressure (saturation temperature)						Power consumption			
		Return gas temp.		Liquid temp.		Cooling capacity		COP	EER		P1	I	Ref. mass flow		
		pe	pc	RGT	Tliq	[W]	[Btu/h]	[kcal/h]	[W/W]	[Btu/Wh]	[kcal/Wh]	[W]	[A]	[kg/h]	
[°C]	-23	54	32	32	451,3	1541	388,4	1,23	4,19	1,06	367,7	4,53	10,52	ASHRAE LBP	
[°F]	-10	130	90	90											
[°C]	-25	55	32	55	305,5	1043	262,9	0,87	2,95	0,74	353,1	4,44	9,55	cecomaf LBP	
[°F]	-13	131	90	131											
[°C]	-35	40	20	40	248,1	847	213,5	0,93	3,19	0,80	266,0	3,90	6,74	EN12900 LBP	
[°F]	-31	104	68	104											
[°C]	-23	49	4,4	49	340,3	1162	292,9	0,94	3,20	0,81	362,8	4,46	12,05	ARI540 LBP	
[°F]	-10	120	40	120											
[°C]	-23	41	32	32	512,7	1751	441,2	1,46	4,98	1,26	351,5	4,37	11,95	AHAM LBP	
[°F]	-10	105	90	90											
[°C]	-35	45	32	45	230,4	787	198,3	0,86	2,95	0,74	267,1	3,91	6,16	opt	
[°F]	-31	113	90	113											

Performance tables

R404A, 115V/60Hz, CSIR, fan 3m/s, UL, CCC

	pe		Cooling capacity			COP	EER	P1			I	m
	[°C]	[°F]	[W]	[Btu/h]	[kcal/h]	[W/W]	[Btu/Wh]	[kcal/Wh]	[W]	[A]	[kg/h]	
[°C / °F]	-45	-49	111,0	379	95,5	0,59	2,00	0,50	189,4	3,64	2,95	
cond. pressure	-34	-30	238,3	814	205,1	0,88	3,00	0,76	271,4	3,93	6,37	
pc= 45/113	-23	-10	429,9	1468	370,0	1,20	4,10	1,03	358,2	4,42	11,62	
return gas temp.	-15	5	623,2	2128	536,4	1,46	4,98	1,25	427,8	4,91	17,02	
RGT= 32/90	-4	25	961,8	3285	827,7	1,81	6,17	1,56	532,2	5,74	26,80	
liquid temp	0	32	1105,1	3774	951,1	1,93	6,59	1,66	572,9	6,07	31,07	
Tliq= 45/113	7,2	45	1409,4	4813	1213,0	2,15	7,34	1,85	656,1	6,76	40,42	
[°C / °F]	-45	-49	70,3	240	60,5	0,40	1,37	0,34	175,3	3,60	2,16	
cond. pressure	-34	-30	174,3	595	150,0	0,65	2,21	0,56	269,5	3,96	5,39	
pc= 55/131	-23	-10	333,3	1138	286,8	0,91	3,09	0,78	368,2	4,53	10,44	
return gas temp	-15	5	496,7	1696	427,5	1,11	3,80	0,96	446,0	5,09	15,75	
RGT= 32/90	-4	25	788,1	2692	678,3	1,41	4,80	1,21	560,4	6,00	25,58	
liquid temp	0	32	913,0	3118	785,7	1,51	5,16	1,30	604,5	6,36	29,94	
Tliq= 55/131	7,2	45	1180,3	4031	1015,7	1,70	5,81	1,46	693,4	7,09	39,61	