

## Model

Designation	<b>NL10MF</b>	220-240V/50Hz 1~ 208-230V/60Hz 1~	Sales code:	<b>105G6885</b>
-------------	---------------	-----------------------------------	-------------	-----------------

## Compressor design

Oil type	Polyolester	Refrigerant(s)	<b>R134a</b>
Oil viscosity	32cST	Displacement	10,09cm <sup>3</sup> / 0,62cu.in
Oil quantity	298cm <sup>3</sup> / 10,1fl.oz	Compressors on pallet	80
Refr. charge - tech. limit	600g / 21,2oz		
Free gas volume comp.	2360cm <sup>3</sup> / 79,8fl.oz		
Weight	10,5kg / 23,1lbs		
Motor protection	1# internal		
Winding resistance main	6,1Ω (at 25°C)		
Winding resistance aux	17,5Ω (at 25°C)		
Max. winding temp.	125°C / 257°F		
Max. discharge temp.	130°C / 266°F		



## General - Configurations with NL10MF

	<b>Conf. 1</b>	<b>Conf. 2</b>	<b>Conf. 3</b>	<b>Conf. 4</b>
Motorconfiguration	RSIR	CSIR	RSIR	CSIR
Power supply (nominal)	220-240V/50Hz	220-240V/50Hz	208-230V/60Hz	208-230V/60Hz
Number of phases	1	1	1	1
Voltage range	187-254V	187-254V	187-254V	187-254V
Approvals	VDE, EAC, CCC, UL, KC	VDE, EAC, CCC, UL, KC	VDE, EAC, CCC, UL, KC	VDE, EAC, CCC, UL, KC
Starting torque	LST	HST	LST	HST
Note	- / -			

## Applications with NL10MF

	<b>Conf. 1</b>	<b>Conf. 2</b>	<b>Conf. 3</b>	<b>Conf. 4</b>
Refrigerant	R134a	R134a	R134a	R134a
Application	MBP	MBP	MBP	MBP
System cooling	fan 1,5m/s	fan 1,5m/s	fan 1,5m/s	fan 1,5m/s
Hot gas defrost	OK	OK	OK	OK
Long interval pull down	OK	OK	OK	OK

## Electrical data - Configurations with NL10MF

	<b>Conf. 1</b>	<b>Conf. 2</b>	<b>Conf. 3</b>	<b>Conf. 4</b>
Starting device type	PTC	relay	PTC	relay
Run capacitor	- / -	- / -	- / -	- / -
Start capacitor	- / -	125μF	- / -	125μF
LRA (locked rotor amps / 4s)	13A	16,6A	11,7A	16,1A
RLA (rated load amps / 1s)	2,8A	2,8A	2,4A	2,4A
Cut in current	17A	17A	15,5A	15,5A

## Model

Designation

**NL10MF**

220-240V/50Hz 1~ 208-230V/60Hz 1~

Sales code:

**105G6885**

## Compressor dimensions

<b>Housing</b>	A Height	203mm / 7,99in
	B Height	197mm / 7,76in
	C Length shell	205mm / 8,07in
	D Length w. cover	254mm / 10in
	E Width	166mm / 6,54in

Connectors		Suction	Discharge	Process
		X	Y	Z
Diameter	[mm]	øi 8,11-8,29	øi 6,11-6,29	øi 6,11-6,29
	(i:inside, o:outside) [in]	øi 0,32-0,33	øi 0,24-0,25	øi 0,24-0,25
Material		copper	copper	copper
Horizontal angle	±2°	0°	0°	0°
Vertical angle	±2°	15°	35°	155°
Position l/h/w	[mm]	126/76/78	133/103/54	-107/94/72
	[in]	4,9/3/3,1	5,2/4/2,1	-4,2/3,7/2,8
Straight tube l.	[mm]	12	12	12
	[in]	0,5	0,5	0,5

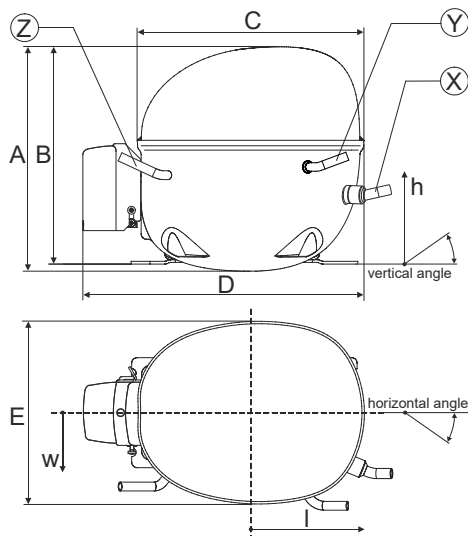

## Compressor fixation

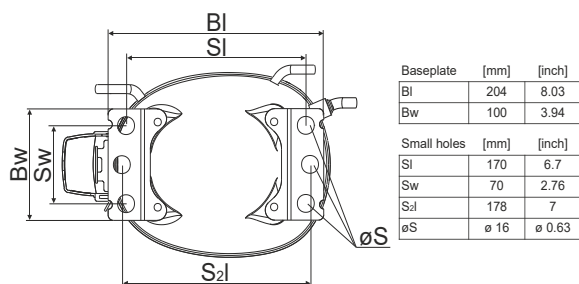

### Bolt joint

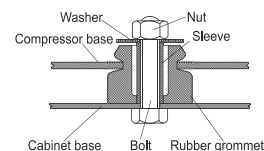

### Snap-on

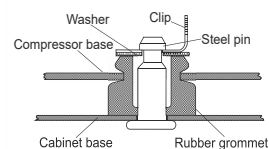

## Mounting accessories

	one comp.	multi pack
Bolt joint   M6   ø16mm	118-1917	118-1918
Bolt joint   ø1/4"   ø16mm	118-1946	
Bolt joint   ø1/4"   ø19mm	118-1949	
Snap-on   ø7,3   ø16mm	118-1947	118-1919

## Application notes

LRA value on compressor label and datasheet may differ due to different test conditions for UL approval.

Provision for PE Grounding is located at the PE Stamp on the compressor

## Model

Designation	<b>NL10MF</b>	<b>220-240V/50Hz</b>	<b>Conf. 1</b>	Sales code:	<b>105G6885</b>
-------------	---------------	----------------------	----------------	-------------	-----------------

## Configuration

Motorconfiguration	RSIR
Power supply (nominal)	220-240V/50Hz 1~
Refrigerant	R134a
Application	MBP
Voltage range	187-254V
Starting torque	LST
Approvals	VDE (2)
(1): Made in China	EAC (1),(2)
(2): Made in Slovakia	CCC (1),(2)
	UL (1),(2)
	KC (1)

## Electrical accessories / wiring diagram

RSIR

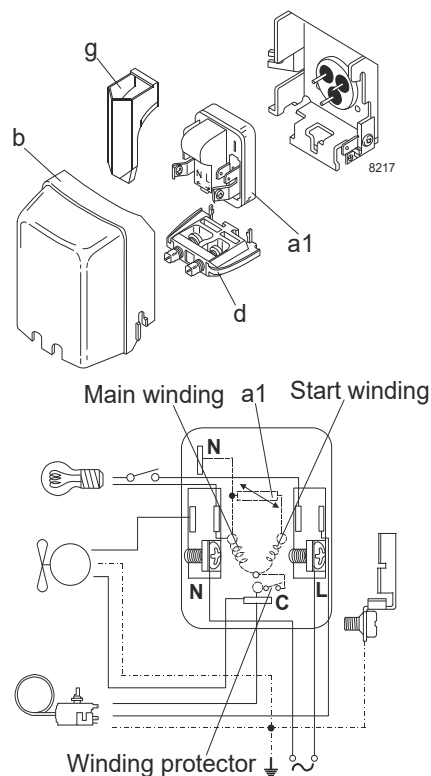

## Ambient/ machine room temperatures minimum /maximum

Ambient temperature range:	10 - 43°C / 50 - 110°F
Machine room temperature range:	10 - 48°C / 50 - 119°F
Compressor cooling:	fan 1,5m/s

## Operation Limits

### Operation pressure range

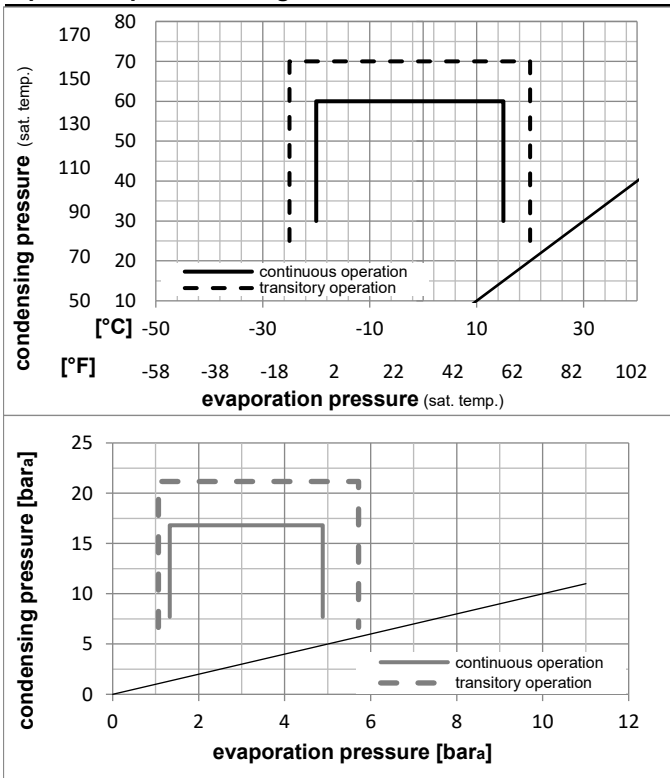

### Components

a1	PTC starter (220V, 250hm, 4.8mm)	103N0018
b	plastic cover	103N2011
d	cord relief	103N1010
g	protection screen for PTC	103N0476

### Alternative components

a1	PTC starter (220V, 250hm, 6.3mm)	103N0011
b	plastic cover	103N2010
d	cord relief	103N1010
g	protection screen for PTC	103N0476

### Model

Designation **NL10MF** **220-240V/50Hz** Conf. 1 Sales code: **105G6885**

### Optimization + standard conditions

R134a, 220V/50Hz, RSIR, fan 1,5m/s, VDE, EAC, CCC, UL, KC

	Evaporating pressure (saturation temperature)				Condensing pressure (saturation temperature)			Return gas temp.	Liquid temp.	Cooling capacity	COP	EER	Power consumption			ASHRAE MBP
	pe	pc	RGT	Tliq	[W]	[Btu/h]	[kcal/h]						P1	I	Ref. mass flow	
[°C]	-7	54	35	46	569,6	1945	490,2	1,64	5,62	1,42	346,3	2,33	12,43			
[°F]	20	130	95	115												
	-10	55	32	55	441,0	1506	379,5	1,37	4,67	1,18	322,7	2,25	10,66	cecomaf MBP		
	-10	45	20	45	496,5	1696	427,3	1,61	5,50	1,39	308,3	2,20	11,62	EN12900 MBP		
	-7	49	18	49	540,7	1847	465,4	1,61	5,49	1,38	336,3	2,29	13,36	ARI540 MBP		
	-10	45	32	45	515,2	1759	443,3	1,67	5,71	1,44	308,3	2,20	11,27	opt		
	-25	45	32	45	240,6	822	207,0	1,12	3,81	0,96	215,5	2,00	5,21	opt		

### Performance tables

R134a, 220V/50Hz, RSIR, fan 1,5m/s, VDE, EAC, CCC, UL, KC

	pe		Cooling capacity			COP	EER	P1	I	m	
	[°C]	[°F]	[W]	[Btu/h]	[kcal/h]	[W/W]	[Btu/Wh]	[kcal/Wh]	[W]	[A]	[kg/h]
[°C / °F]	-20	-4	316,1	1080	272,1	1,29	4,40	1,11	245,6	2,05	6,87
cond. pressure	-15	5	406,9	1390	350,2	1,47	5,02	1,27	276,6	2,12	8,87
pc= 45/113	-10	14	515,2	1759	443,3	1,67	5,71	1,44	308,3	2,20	11,27
return gas temp.	-5	23	643,4	2197	553,7	1,89	6,46	1,63	340,3	2,29	14,15
RGT= 32/90	0	32	794,0	2712	683,3	2,13	7,28	1,84	372,2	2,40	17,56
liquid temp	5	41	969,3	3310	834,2	2,40	8,20	2,07	403,7	2,53	21,58
Tliq= 45/113	15	59	1403,9	4795	1208,2	3,02	10,33	2,60	464,2	2,81	31,80
[°C / °F]	-20	-4	265,6	907	228,6	1,06	3,61	0,91	251,4	2,06	6,37
cond. pressure	-15	5	345,7	1181	297,5	1,21	4,12	1,04	286,4	2,15	8,32
pc= 55/131	-10	14	441,0	1506	379,5	1,37	4,67	1,18	322,7	2,25	10,66
return gas temp	-5	23	554,0	1892	476,8	1,54	5,26	1,33	359,7	2,37	13,47
RGT= 32/90	0	32	687,1	2347	591,3	1,73	5,91	1,49	397,2	2,50	16,81
liquid temp	5	41	842,7	2878	725,2	1,94	6,62	1,67	434,9	2,65	20,76
Tliq= 55/131	15	59	1230,8	4203	1059,2	2,42	8,26	2,08	509,1	2,98	30,91

## Model

Designation	<b>NL10MF</b>	<b>220-240V/50Hz</b>	<b>Conf. 2</b>	Sales code:	<b>105G6885</b>
-------------	---------------	----------------------	----------------	-------------	-----------------

## Configuration

Motorconfiguration	CSIR
Power supply (nominal)	220-240V/50Hz 1~
Refrigerant	R134a
Application	MBP
Voltage range	187-254V
Starting torque	HST
Approvals	VDE (2)
	(1): Made in China EAC (1),(2)
	(2): Made in Slovakia CCC (1),(2)
	UL (1),(2)
	KC (1)

## Electrical accessories / wiring diagram

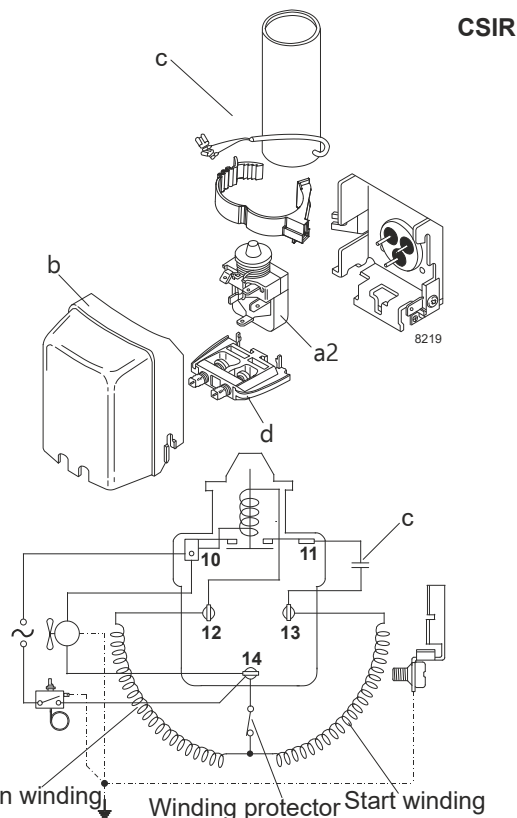

## Ambient/ machine room temperatures minimum /maximum

Ambient temperature range:	10 - 43°C / 50 - 110°F
Machine room temperature range:	10 - 48°C / 50 - 119°F
Compressor cooling:	fan 1,5m/s

## Operation Limits

### Operation pressure range

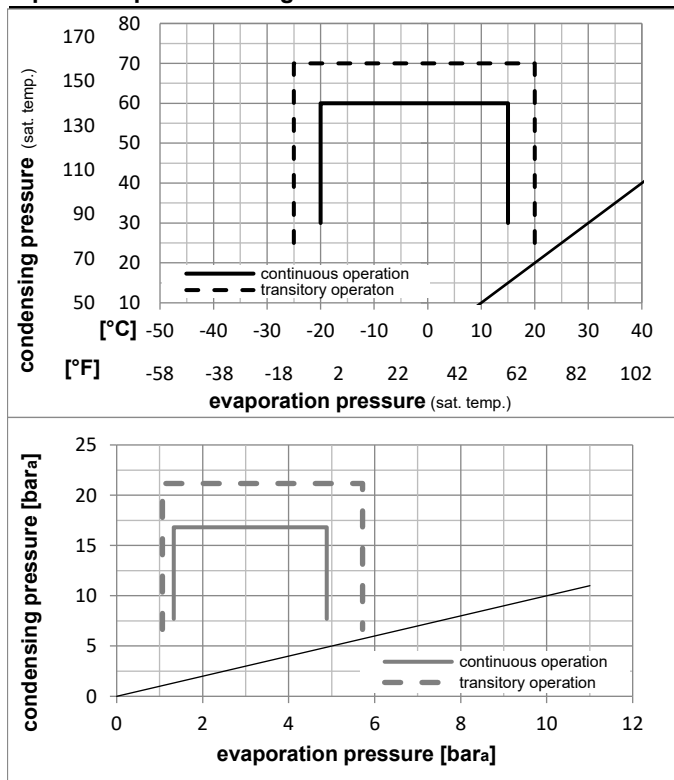

### Components

a2	relay	117U6022
c	start capacitor	117U5018
b	plastic cover	103N2011
d	cord relief	103N1010

### Model

Designation **NL10MF** **220-240V/50Hz** Conf. 2 Sales code: **105G6885**

### Optimization + standard conditions

R134a, 220V/50Hz, CSIR, fan 1,5m/s, VDE, EAC, CCC, UL, KC

		Evaporating pressure (saturation temperature)				Condensing pressure (saturation temperature)						Power consumption			
		Return gas temp.		Liquid temp.		Cooling capacity		COP	EER		P1	I	Ref. mass flow		
		pe	pc	RGT	Tliq	[W]	[Btu/h]	[kcal/h]	[W/W]	[Btu/Wh]	[kcal/Wh]	[W]	[A]	[kg/h]	
[°C]	[°F]														
[°C]	-7	54	35	46	569,6	1945	490,2	1,64	5,62	1,42	346,3	2,33	12,43	ASHRAE MBP	
[°F]	20	130	95	115											
[°C]	-10	55	32	55	441,0	1506	379,5	1,37	4,67	1,18	322,7	2,25	10,66	cecomaf MBP	
[°F]	14	131	90	131											
[°C]	-10	45	20	45	496,5	1696	427,3	1,61	5,50	1,39	308,3	2,20	11,62	EN12900 MBP	
[°F]	14	113	68	113											
[°C]	-7	49	18	49	540,7	1847	465,4	1,61	5,49	1,38	336,3	2,29	13,36	ARI540 MBP	
[°F]	20	120	65	120											
[°C]	-10	45	32	45	515,2	1759	443,3	1,67	5,71	1,44	308,3	2,20	11,27	opt	
[°F]	14	113	90	113											
[°C]	-25	45	32	45	240,6	822	207,0	1,12	3,81	0,96	215,5	2,00	5,21	opt	
[°F]	-13	113	90	113											

### Performance tables

R134a, 220V/50Hz, CSIR, fan 1,5m/s, VDE, EAC, CCC, UL, KC

	pe		Cooling capacity			COP	EER	P1	I	m	
	[°C]	[°F]	[W]	[Btu/h]	[kcal/h]	[W/W]	[Btu/Wh]	[kcal/Wh]	[W]	[A]	[kg/h]
[°C / °F]	-20	-4	316,1	1080	272,1	1,29	4,40	1,11	245,6	2,05	6,87
cond. pressure	-15	5	406,9	1390	350,2	1,47	5,02	1,27	276,6	2,12	8,87
pc= 45/113	-10	14	515,2	1759	443,3	1,67	5,71	1,44	308,3	2,20	11,27
return gas temp.	-5	23	643,4	2197	553,7	1,89	6,46	1,63	340,3	2,29	14,15
RGT= 32/90	0	32	794,0	2712	683,3	2,13	7,28	1,84	372,2	2,40	17,56
liquid temp	5	41	969,3	3310	834,2	2,40	8,20	2,07	403,7	2,53	21,58
Tliq= 45/113	15	59	1403,9	4795	1208,2	3,02	10,33	2,60	464,2	2,81	31,80
[°C / °F]	-20	-4	265,6	907	228,6	1,06	3,61	0,91	251,4	2,06	6,37
cond. pressure	-15	5	345,7	1181	297,5	1,21	4,12	1,04	286,4	2,15	8,32
pc= 55/131	-10	14	441,0	1506	379,5	1,37	4,67	1,18	322,7	2,25	10,66
return gas temp	-5	23	554,0	1892	476,8	1,54	5,26	1,33	359,7	2,37	13,47
RGT= 32/90	0	32	687,1	2347	591,3	1,73	5,91	1,49	397,2	2,50	16,81
liquid temp	5	41	842,7	2878	725,2	1,94	6,62	1,67	434,9	2,65	20,76
Tliq= 55/131	15	59	1230,8	4203	1059,2	2,42	8,26	2,08	509,1	2,98	30,91

## Model

Designation	<b>NL10MF</b>	<b>208-230V/60Hz</b>	<b>Conf. 3</b>	Sales code:	<b>105G6885</b>
-------------	---------------	----------------------	----------------	-------------	-----------------

## Configuration

Motorconfiguration	RSIR
Power supply (nominal)	208-230V/60Hz 1~
Refrigerant	R134a
Application	MBP
Voltage range	187-254V
Starting torque	LST
Approvals	VDE (2)
(1): Made in China	EAC (1),(2)
	CCC (1),(2)
	UL (1),(2)
	KC (1)

## Electrical accessories / wiring diagram

RSIR

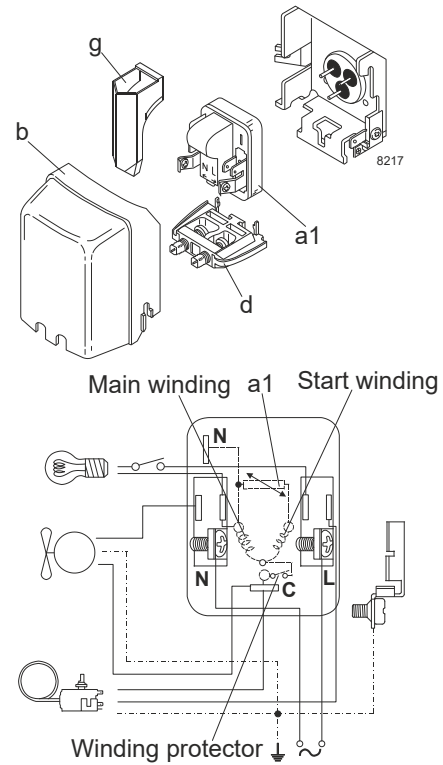

## Ambient/ machine room temperatures minimum /maximum

Ambient temperature range:	10 - 43°C / 50 - 110°F
Machine room temperature range:	10 - 48°C / 50 - 119°F
Compressor cooling:	fan 1,5m/s

## Operation Limits

### Operation pressure range

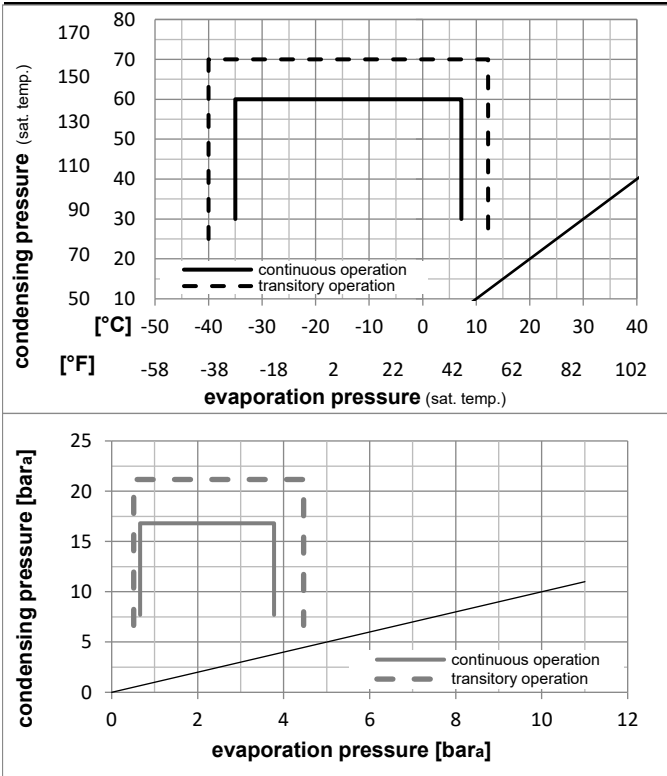

### Components

a1	PTC starter (220V, 250hm, 4.8mm)	103N0018
b	plastic cover	103N2011
d	cord relief	103N1010
g	protection screen for PTC	103N0476

### Alternative components

a1	PTC starter (220V, 250hm, 6.3mm)	103N0011
b	plastic cover	103N2010
d	cord relief	103N1010
g	protection screen for PTC	103N0476

### Model

Designation **NL10MF** **208-230V/60Hz** Conf. 3 Sales code: **105G6885**

### Optimization + standard conditions

R134a, 220V/60Hz, RSIR, fan 1,5m/s, VDE, EAC, CCC, UL, KC

	Evaporating pressure (saturation temperature)				Condensing pressure (saturation temperature)						Power consumption			ASHRAE MBP
	pe	pc	RGT	Tliq	Cooling capacity	COP	EER	P1	I	Ref. mass flow				
	[°C]	[°F]	[W]	[Btu/h]	[kcal/h]	[W/W]	[Btu/Wh]	[kcal/Wh]	[W]	[A]	[kg/h]			
	-7	54	35	46	668,7	2284	575,5	1,66	5,66	1,43	403,8	2,33	14,59	ASHRAE MBP
	[°F]	20	130	95	115									
	-10	55	32	55	517,7	1768	445,6	1,39	4,74	1,19	373,2	2,21	12,52	cecomaf MBP
	[°F]	14	131	90	131									
	-10	45	20	45	582,9	1991	501,7	1,65	5,64	1,42	353,1	2,14	13,65	EN12900 MBP
	[°F]	14	113	68	113									
	-7	49	18	49	634,8	2168	546,3	1,63	5,57	1,40	388,9	2,28	15,68	ARI540 MBP
	[°F]	20	120	65	120									
	-10	45	32	45	604,8	2065	520,5	1,71	5,85	1,47	353,1	2,14	13,24	opt
	[°F]	14	113	90	113									
	-25	45	32	45	282,4	964	243,0	1,20	4,09	1,03	235,8	1,73	6,12	opt
	[°F]	-13	113	90	113									

### Performance tables

R134a, 220V/60Hz, RSIR, fan 1,5m/s, VDE, EAC, CCC, UL, KC

	pe		Cooling capacity			COP	EER	P1	I	m	
	[°C]	[°F]	[W]	[Btu/h]	[kcal/h]	[W/W]	[Btu/Wh]	[kcal/Wh]	[W]	[A]	[kg/h]
[°C / °F]	-35	-31	147,1	502	126,6	0,91	3,11	0,78	161,3	1,51	3,17
cond. pressure	-25	-13	282,4	964	243,0	1,20	4,09	1,03	235,8	1,73	6,12
pc= 45/113	-15	5	477,7	1631	411,1	1,52	5,20	1,31	313,6	1,99	10,41
return gas temp.	-10	14	604,8	2065	520,5	1,71	5,85	1,47	353,1	2,14	13,24
RGT= 32/90	-5	23	755,3	2580	650,1	1,92	6,57	1,65	392,8	2,30	16,61
liquid temp	0	32	932,1	3183	802,2	2,16	7,36	1,85	432,5	2,47	20,61
Tliq= 45/113	7,2	45	1238,5	4230	1065,9	2,53	8,65	2,18	489,2	2,74	27,66
[°C / °F]	-35	-31	109,2	373	93,9	0,76	2,61	0,66	143,0	1,44	2,60
cond. pressure	-25	-13	232,9	795	200,4	1,00	3,43	0,86	232,1	1,71	5,57
pc= 55/131	-15	5	405,8	1386	349,2	1,25	4,26	1,07	325,5	2,03	9,77
return gas temp	-10	14	517,7	1768	445,6	1,39	4,74	1,19	373,2	2,21	12,52
RGT= 32/90	-5	23	650,4	2221	559,8	1,54	5,27	1,33	421,4	2,40	15,81
liquid temp	0	32	806,7	2755	694,2	1,72	5,86	1,48	469,8	2,60	19,73
Tliq= 55/131	7,2	45	1078,7	3684	928,4	2,00	6,83	1,72	539,5	2,91	26,68



## Model

Designation	<b>NL10MF</b>	<b>208-230V/60Hz</b>	<b>Conf. 4</b>	Sales code:	<b>105G6885</b>
-------------	---------------	----------------------	----------------	-------------	-----------------

## Configuration

Motorconfiguration	CSIR
Power supply (nominal)	208-230V/60Hz 1~
Refrigerant	R134a
Application	MBP
Voltage range	187-254V
Starting torque	HST
Approvals	VDE (2)
	(1): Made in China EAC (1),(2)
	(2): Made in Slovakia CCC (1),(2)
	UL (1),(2)
	KC (1)

## Electrical accessories / wiring diagram

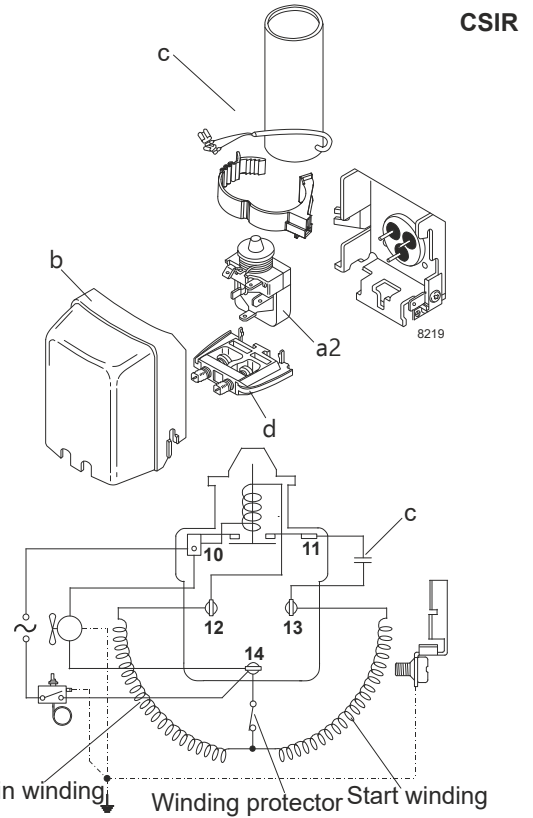

## Ambient/ machine room temperatures minimum /maximum

Ambient temperature range:	10 - 43°C / 50 - 110°F
Machine room temperature range:	10 - 48°C / 50 - 119°F
Compressor cooling:	fan 1,5m/s

## Operation Limits

## Operation pressure range

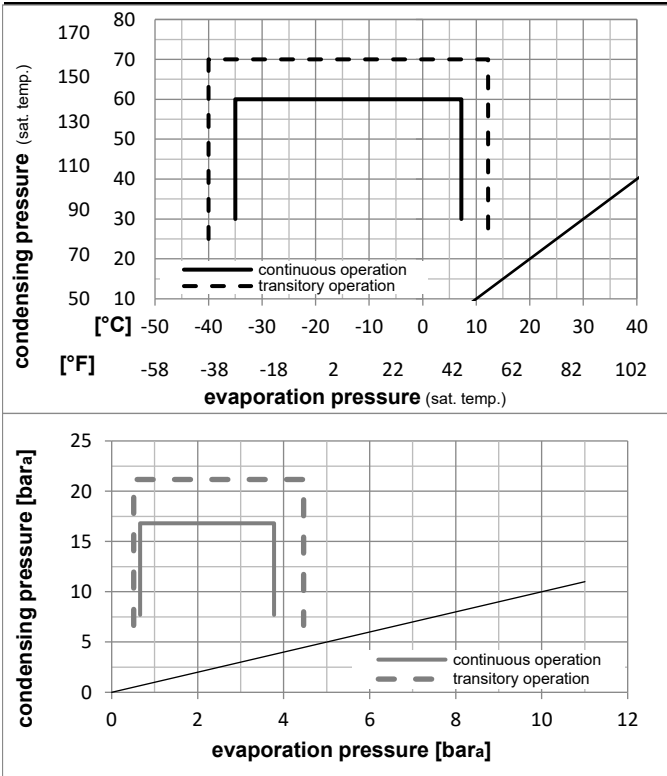

## Components

a2	relay	117U6022
c	start capacitor	117U5018
b	plastic cover	103N2011
d	cord relief	103N1010

### Model

Designation **NL10MF** **208-230V/60Hz** Conf. 4 Sales code: **105G6885**

### Optimization + standard conditions

R134a, 220V/60Hz, CSIR, fan 1,5m/s, VDE, EAC, CCC, UL, KC

	Evaporating pressure (saturation temperature)				Condensing pressure (saturation temperature)						Power consumption			ASHRAE MBP				
	pe	pc	RGT	Tliq	Cooling capacity	COP	EER	P1	I	Ref. mass flow								
	[°C]	[°F]	[°C]	[°F]	[W]	[Btu/h]	[kcal/h]	[W/W]	[Btu/Wh]	[kcal/Wh]	[W]	[A]	[kg/h]					
	-7	20	54	130	35	95	46	115	668,7	2284	575,5	1,66	5,66	1,43	403,8	2,33	14,59	ASHRAE MBP
	-10	14	55	131	32	90	55	131	517,7	1768	445,6	1,39	4,74	1,19	373,2	2,21	12,52	cecomaf MBP
	-10	14	45	113	20	68	45	113	582,9	1991	501,7	1,65	5,64	1,42	353,1	2,14	13,65	EN12900 MBP
	-7	20	49	120	18	65	49	120	634,8	2168	546,3	1,63	5,57	1,40	388,9	2,28	15,68	ARI540 MBP
	-10	14	45	113	32	90	45	113	604,8	2065	520,5	1,71	5,85	1,47	353,1	2,14	13,24	opt
	-25	-13	45	113	32	90	45	113	282,4	964	243,0	1,20	4,09	1,03	235,8	1,73	6,12	opt

### Performance tables

R134a, 220V/60Hz, CSIR, fan 1,5m/s, VDE, EAC, CCC, UL, KC

	pe		Cooling capacity			COP	EER	P1	I	m	
	[°C]	[°F]	[W]	[Btu/h]	[kcal/h]	[W/W]	[Btu/Wh]	[kcal/Wh]	[W]	[A]	[kg/h]
[°C / °F]	-35	-31	147,1	502	126,6	0,91	3,11	0,78	161,3	1,51	3,17
cond. pressure	-25	-13	282,4	964	243,0	1,20	4,09	1,03	235,8	1,73	6,12
pc= 45/113	-15	5	477,7	1631	411,1	1,52	5,20	1,31	313,6	1,99	10,41
return gas temp.	-10	14	604,8	2065	520,5	1,71	5,85	1,47	353,1	2,14	13,24
RGT= 32/90	-5	23	755,3	2580	650,1	1,92	6,57	1,65	392,8	2,30	16,61
liquid temp	0	32	932,1	3183	802,2	2,16	7,36	1,85	432,5	2,47	20,61
Tliq= 45/113	7,2	45	1238,5	4230	1065,9	2,53	8,65	2,18	489,2	2,74	27,66
[°C / °F]	-35	-31	109,2	373	93,9	0,76	2,61	0,66	143,0	1,44	2,60
cond. pressure	-25	-13	232,9	795	200,4	1,00	3,43	0,86	232,1	1,71	5,57
pc= 55/131	-15	5	405,8	1386	349,2	1,25	4,26	1,07	325,5	2,03	9,77
return gas temp	-10	14	517,7	1768	445,6	1,39	4,74	1,19	373,2	2,21	12,52
RGT= 32/90	-5	23	650,4	2221	559,8	1,54	5,27	1,33	421,4	2,40	15,81
liquid temp	0	32	806,7	2755	694,2	1,72	5,86	1,48	469,8	2,60	19,73
Tliq= 55/131	7,2	45	1078,7	3684	928,4	2,00	6,83	1,72	539,5	2,91	26,68