

## Model

Designation	<b>NLE10CNT</b>	220-230V/50Hz 1~ 208-230V/60Hz 1~	Sales code:	<b>105H6179</b>
-------------	-----------------	-----------------------------------	-------------	-----------------

## Compressor design

Oil type	Polyolester	Refrigerant(s)	<b>R290</b>
Oil viscosity	32cST	Displacement	10,09cm <sup>3</sup> / 0,62cu.in
Oil quantity	268cm <sup>3</sup> / 9,1fl.oz	Compressors on pallet	80
Refr. charge - tech. limit	400g / 14,1oz		
Free gas volume comp.	2360cm <sup>3</sup> / 79,8fl.oz		
Weight	11,8kg / 26lbs		
Motor protection	1# internal		
Winding resistance main	4,47Ω (at 25°C)		
Winding resistance aux	18,69Ω (at 25°C)		
Max. winding temp.	125°C / 257°F		
Max. discharge temp.	120°C / 248°F		



## General - Configurations with NLE10CNT

	<b>Conf. 1</b>	<b>Conf. 2</b>	<b>Conf. 3</b>	<b>Conf. 4</b>	<b>Conf. 5</b>
Motorconfiguration	CSIR	CSIR	RSIR	RSCR	RSCR
Power supply (nominal)	208-230V/60Hz	220-230V/50Hz	220-230V/50Hz	208-230V/60Hz	220-230V/50Hz
Number of phases	1	1	1	1	1
Voltage range	187-253V	187-242V	187-242V	187-253V	187-242V
Approvals	UL, CB, CCC	UL, CB, CCC	UL, CB	UL, CB	UL, CB
Starting torque	HST	HST	LST	LST	LST
Note	Important !! CSIR configuration uses different relays for 50Hz and 60Hz. Check accessories table.				

## Applications with NLE10CNT

	<b>Conf. 1</b>	<b>Conf. 2</b>	<b>Conf. 3</b>	<b>Conf. 4</b>	<b>Conf. 5</b>
Refrigerant	R290	R290	R290	R290	R290
Application	LBP+MBP	LBP+MBP	LBP+MBP	LBP+MBP	LBP+MBP
System cooling	fan 3m/s	fan 3m/s	fan 3m/s	fan 3m/s	fan 3m/s
Hot gas defrost	OK	OK	OK	OK	OK
Long interval pull down	OK	OK	OK	OK	OK

## Electrical data - Configurations with NLE10CNT

	<b>Conf. 1</b>	<b>Conf. 2</b>	<b>Conf. 3</b>	<b>Conf. 4</b>	<b>Conf. 5</b>
Starting device type	relay	relay	PTC	PTC	PTC
Run capacitor	-/-	-/-	-/-	4μF	4μF
Start capacitor	60μF	60μF	-/-	-/-	-/-
LRA (locked rotor amps / 4s)	17,1A	17,1A	16,6A	15,8A	16,6A
RLA (rated load amps / 1s)	2,4A	3,4A	3,4A	2,3A	3A
Cut in current	17,1A	17,1A	20,7A	19,6A	20,7A

## Model

Designation

**NLE10CNT**

220-230V/50Hz 1~ 208-230V/60Hz 1~

Sales code:

**105H6179**

## Compressor dimensions

Housing	A Height	203mm / 7,99in
	B Height	197mm / 7,76in
	C Length shell	205mm / 8,07in
	D Length w. cover	254mm / 10in
	E Width	166mm / 6,54in

Connectors		Suction	Discharge	Process
		X	Y	Z
Diameter	[mm]	øi 8,11-8,29	øi 6,41-6,59	øi 6,41-6,59
	(i:inside, o:outside) [in]	øi 0,32-0,33	øi 0,25-0,26	øi 0,25-0,26
Material		copper	copper	copper
Horizontal angle	±2°	0°	0°	0°
Vertical angle	±2°	15°	21°	155°
Position l/h/w	[mm]	132/69/57	94/102/81	-109/94/72
	[in]	5,2/2,7/2,2	3,7/4/3,2	-4,3/3,7/2,8
Straight tube l.	[mm]	12	12	12
	[in]	0,5	0,5	0,5

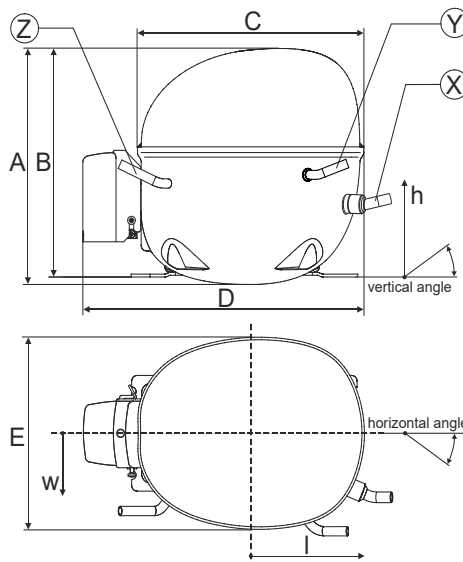

## Compressor fixation

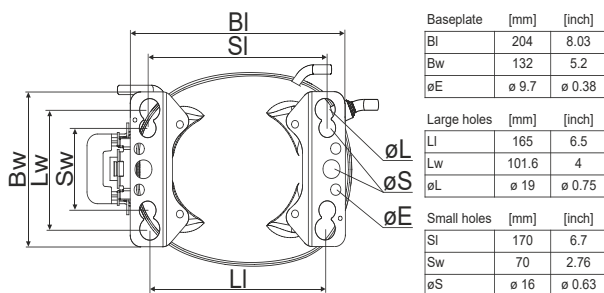

### Bolt joint

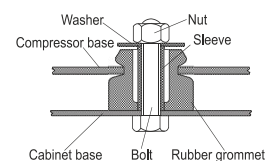

### Snap-on

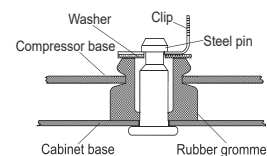

Mounting accessories	one comp.	multi pack
Bolt joint   M6   ø16mm	118-1917	118-1918
Bolt joint   ø1/4"   ø16mm	118-1946	
Bolt joint   ø1/4"   ø19mm	118-1949	
Snap-on   ø7,3   ø16mm	118-1947	118-1919

## Application notes

LRA value on compressor label and datasheet may differ due to different test conditions for UL approval.

Provision for PE Grounding is located at the PE Stamp on the compressor

### Model

Designation	<b>NLE10CNT</b>	<b>208-230V/60Hz</b>	Conf. 1	Sales code:	<b>105H6179</b>
-------------	-----------------	----------------------	---------	-------------	-----------------

### Configuration

Motorconfiguration	CSIR	
Power supply (nominal)	208-230V/60Hz 1~	
Refrigerant	R290	
Application	LBP+MBP	
Voltage range	187-253V	
Starting torque	HST	
Approvals	UL	SA3693
	CB	
	CCC	

### Electrical accessories / wiring diagram

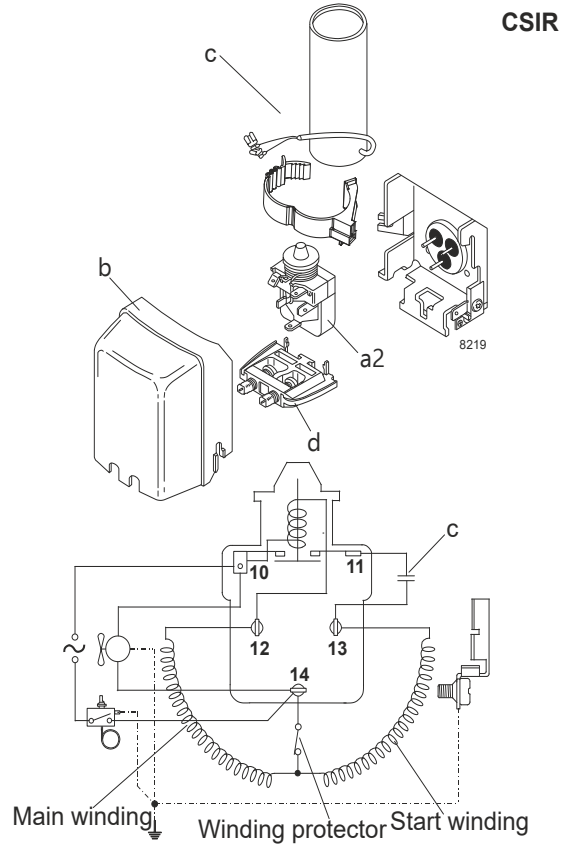

### Ambient/ machine room temperatures minimum /maximum

Ambient temperature range: 10 - 43°C / 50 - 110°F

Machine room temperature range: 10 - 48°C / 50 - 119°F

Compressor cooling: fan 3m/s

### Operation pressure range

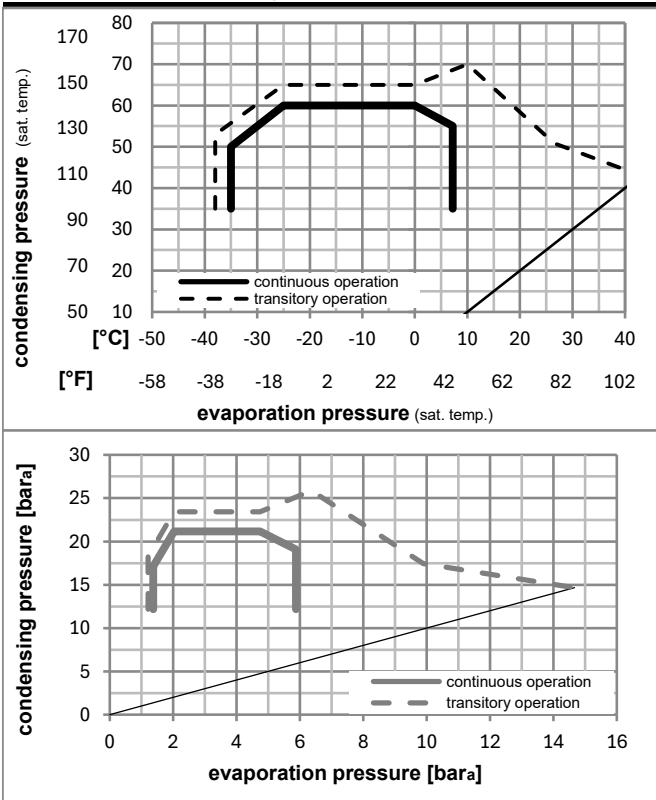

### Components

a2	current relay	117U7050
c	start capacitor (60μF)	117U5014
b	plastic cover	103N2011
d	cord relief	103N1010

## Model

Designation **NLE10CNT** **208-230V/60Hz** Conf. 1 Sales code: **105H6179**

## Optimization + standard conditions

R290, 230V/60Hz, CSIR, fan 3m/s, UL, CB, CCC

	Evaporating pressure (saturation temperature)				Condensing pressure (saturation temperature)			Return gas temp.	Liquid temp.	Cooling capacity	COP	EER	P1	Power consumption		Ref. mass flow	
	pe	pc	RGT	Tliq	[W]	[Btu/h]	[kcal/h]							[W/W]	[Btu/Wh]		
[°C]	-23	54	32	32	605,9	2069	521,4	1,63	5,57	1,40	371,6	2,36	6,14	ASHRAE LBP			
[°F]	-10	130	90	90													
[°C]	-25	55	32	55	451,9	1543	388,9	1,27	4,32	1,09	357,0	2,31	5,63	cecomaf LBP			
[°F]	-13	131	90	131													
[°C]	-35	40	20	40	346,5	1183	298,2	1,29	4,40	1,11	268,7	2,06	3,96	EN12900 LBP			
[°F]	-31	104	68	104													
[°C]	-7	54	35	46	1077,8	3681	927,6	2,10	7,17	1,81	513,4	2,86	12,29	ASHRAE MBP			
[°F]	20	130	95	115													
[°C]	-10	55	32	55	859,9	2937	740,1	1,76	6,01	1,51	488,7	2,77	10,88	cecomaf MBP			
[°F]	14	131	90	131													
[°C]	-10	45	20	45	947,0	3234	815,0	2,12	7,23	1,82	447,6	2,61	11,63	EN12900 MBP			
[°F]	14	113	68	113													

## Performance tables

R290, 230V/60Hz, CSIR, fan 3m/s, UL, CB, CCC

	pe		Cooling capacity			COP	EER		P1	I	m
	[°C]	[°F]	[W]	[Btu/h]	[kcal/h]	[W/W]	[Btu/Wh]	[kcal/Wh]	[W]	[A]	[kg/h]
[°C / °F]	-35	-31	330,1	1127	284,1	1,21	4,15	1,04	271,9	2,06	3,70
cond. pressure	-23	-10	576,1	1968	495,8	1,62	5,53	1,39	356,0	2,31	6,51
pc= 45/113	-15	5	814,7	2782	701,1	1,96	6,71	1,69	414,7	2,50	9,27
return gas temp.	-9	15	1006,2	3437	866,0	2,23	7,62	1,92	451,1	2,63	11,52
RGT= 32/90	-4	25	1225,8	4186	1055,0	2,53	8,65	2,18	484,0	2,75	14,14
liquid temp	0	32	1397,1	4771	1202,4	2,77	9,46	2,38	504,5	2,82	16,21
Tliq= 45/113	7,2	45	1756,1	5997	1511,3	3,28	11,20	2,82	535,3	2,95	20,63
[°C / °F]	-35	-31	257,8	881	221,9	0,96	3,29	0,83	267,5	2,03	3,19
cond. pressure	-23	-10	489,9	1673	421,6	1,32	4,50	1,13	372,1	2,36	6,11
pc= 55/131	-15	5	706,6	2413	608,1	1,58	5,41	1,36	446,2	2,61	8,88
return gas temp	-9	15	878,1	2999	755,7	1,78	6,08	1,53	493,3	2,78	11,12
RGT= 32/90	-4	25	1073,2	3665	923,6	2,00	6,82	1,72	537,3	2,95	13,70
liquid temp	0	32	1224,8	4183	1054,0	2,17	7,39	1,86	565,7	3,06	15,73
Tliq= 55/131	7,2	45	1541,3	5264	1326,5	2,52	8,61	2,17	611,7	3,25	20,08

## Model

Designation	<b>NLE10CNT</b>	<b>220-230V/50Hz</b>	<b>Conf. 2</b>	Sales code:	<b>105H6179</b>
-------------	-----------------	----------------------	----------------	-------------	-----------------

## Configuration

Motorconfiguration	CSIR	
Power supply (nominal)	220-230V/50Hz 1~	
Refrigerant	R290	
Application	LBP+MBP	
Voltage range	187-242V	
Starting torque	HST	
Approvals	UL	SA3693
	CB	
	CCC	

## Electrical accessories / wiring diagram

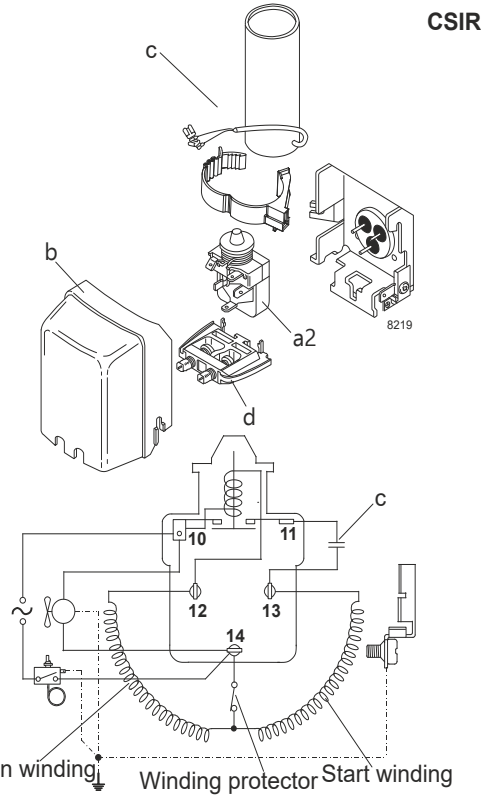

## Ambient/ machine room temperatures minimum /maximum

Ambient temperature range: 10 - 43°C / 50 - 110°F

Machine room temperature range: 10 - 48°C / 50 - 119°F

Compressor cooling: fan 3m/s

## Operation pressure range

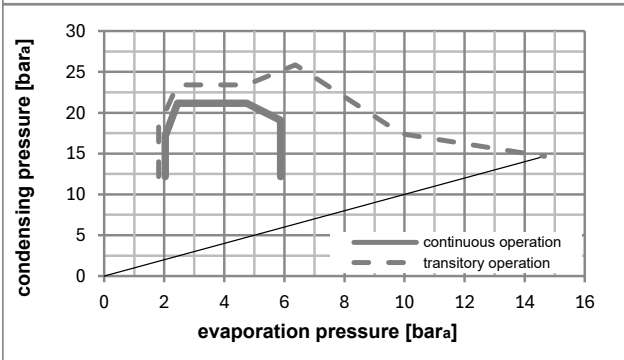
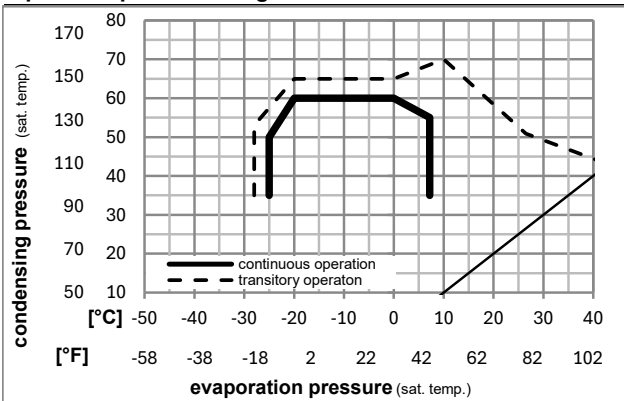

## Components

a2	current relay	117U7019
c	start capacitor (60µF)	117U5014
b	plastic cover	103N2011
d	cord relief	103N1010

### Model

Designation	<b>NLE10CNT</b>	<b>220-230V/50Hz</b>	<b>Conf. 2</b>	Sales code:	<b>105H6179</b>
-------------	-----------------	----------------------	----------------	-------------	-----------------

### Optimization + standard conditions

R290, 230V/50Hz, CSIR, fan 3m/s, UL, CB, CCC

	Evaporating pressure (saturation temperature)				Cooling capacity			COP	EER	P1	Power consumption		Ref. mass flow	
	pe	pc	RGT	Tliq	[W]	[Btu/h]	[kcal/h]				[W]	[A]		
[°C]	-23	54	32	32	509,6	1740	438,6	1,49	5,08	1,28	342,4	2,73	5,16	ASHRAE LBP
[°F]	-10	130	90	90										
[°C]	-25	55	32	55	380,1	1298	327,1	1,16	3,95	1,00	328,7	2,68	4,73	cecomaf LBP
[°F]	-13	131	90	131										
[°C]	-35	40	20	40	291,4	995	250,7	1,19	4,05	1,02	245,6	2,40	3,33	EN12900 LBP
[°F]	-31	104	68	104										
[°C]	-7	54	35	46	907,2	3098	780,7	1,92	6,56	1,65	472,3	3,25	10,35	ASHRAE MBP
[°F]	20	130	95	115										
[°C]	-10	55	32	55	723,8	2472	622,9	1,61	5,49	1,38	450,2	3,16	9,16	cecomaf MBP
[°F]	14	131	90	131										
[°C]	-10	45	20	45	795,4	2717	684,6	1,95	6,68	1,68	406,9	2,97	9,77	EN12900 MBP
[°F]	14	113	68	113										

### Performance tables

R290, 230V/50Hz, CSIR, fan 3m/s, UL, CB, CCC

	pe		Cooling capacity			COP	EER	P1	I	m	
	[°C]	[°F]	[W]	[Btu/h]	[kcal/h]						[W/W]
[°C / °F]	-25	-13	449,0	1534	386,4	1,43	4,88	1,23	314,5	2,62	5,06
cond. pressure	-23	-10	483,6	1651	416,2	1,49	5,08	1,28	325,3	2,66	5,46
pc= 45/113	-15	5	684,1	2336	588,7	1,81	6,18	1,56	377,7	2,85	7,78
return gas temp.	-9	15	845,2	2887	727,4	2,06	7,04	1,77	410,0	2,98	9,68
RGT= 32/90	-4	25	1030,0	3518	886,5	2,34	8,01	2,02	439,3	3,10	11,88
liquid temp	0	32	1174,2	4010	1010,5	2,57	8,77	2,21	457,4	3,18	13,62
Tliq= 45/113	7,2	45	1476,2	5041	1270,4	3,04	10,39	2,62	485,1	3,30	17,34
[°C / °F]	-25	-13	380,1	1298	327,1	1,16	3,95	1,00	328,7	2,68	4,73
cond. pressure	-23	-10	412,1	1407	354,6	1,20	4,11	1,03	342,8	2,73	5,14
pc= 55/131	-15	5	594,7	2031	511,8	1,45	4,94	1,24	411,4	3,00	7,48
return gas temp	-9	15	739,1	2524	636,1	1,63	5,56	1,40	454,3	3,18	9,36
RGT= 32/90	-4	25	903,3	3085	777,4	1,83	6,25	1,57	494,0	3,35	11,53
liquid temp	0	32	1030,7	3520	887,0	1,98	6,78	1,71	519,3	3,46	13,24
Tliq= 55/131	7,2	45	1296,5	4428	1115,7	2,31	7,91	1,99	560,1	3,65	16,89

## Model

Designation	<b>NLE10CNT</b>	<b>220-230V/50Hz</b>	<b>Conf. 3</b>	Sales code:	<b>105H6179</b>
-------------	-----------------	----------------------	----------------	-------------	-----------------

## Configuration

Motorconfiguration	RSIR	
Power supply (nominal)	220-230V/50Hz 1~	
Refrigerant	R290	
Application	LBP+MBP	
Voltage range	187-242V	
Starting torque	LST	
Approvals	UL	SA3693
	CB	

## Electrical accessories / wiring diagram

RSIR

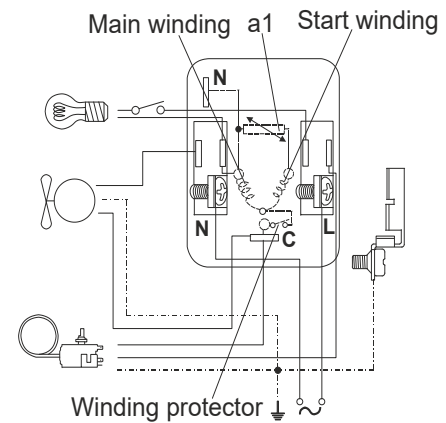
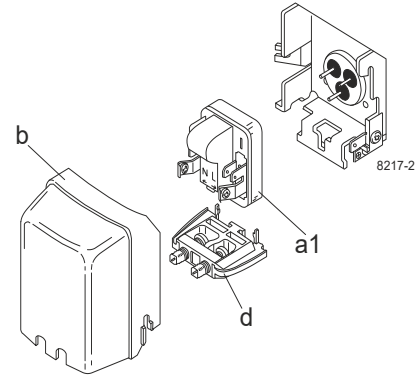

## Ambient/ machine room temperatures minimum /maximum

Ambient temperature range:	10 - 43°C / 50 - 110°F
Machine room temperature range:	10 - 48°C / 50 - 119°F
Compressor cooling:	fan 3m/s

## Operation pressure range

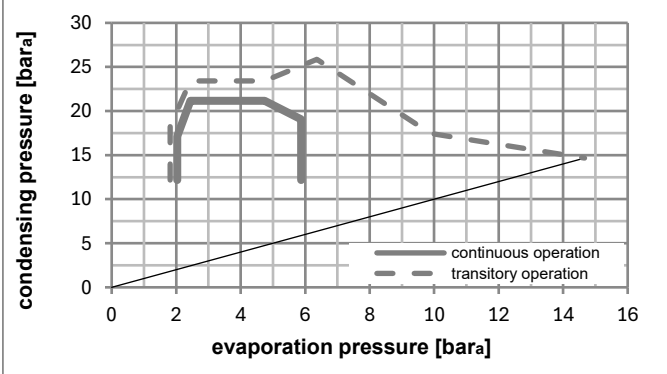
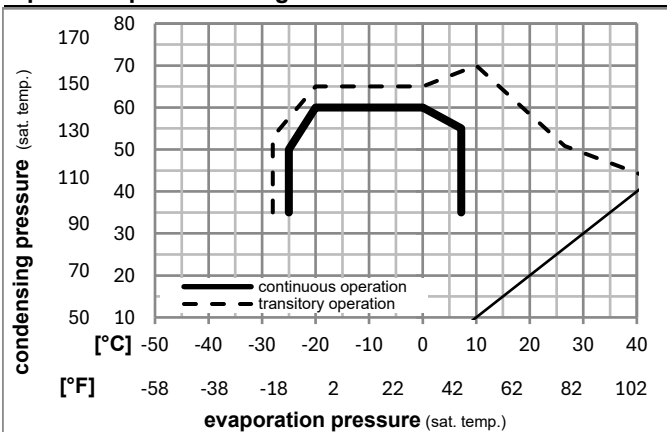

## Components

a1	e-PTC starter (220V, 25Ohm, 4.8mm)	103N0050
b	plastic cover	103N2011
d	cord relief	103N1010

### Model

Designation	<b>NLE10CNT</b>	<b>220-230V/50Hz</b>	<b>Conf. 3</b>	Sales code:	<b>105H6179</b>
-------------	-----------------	----------------------	----------------	-------------	-----------------

### Optimization + standard conditions

R290, 230V/50Hz, RSIR, fan 3m/s, UL, CB

		Evaporating pressure (saturation temperature)				Cooling capacity			COP	EER	Power consumption			
		Condensing pressure (saturation temperature)		Return gas temp.	Liquid temp.	[W]	[Btu/h]	[kcal/h]	[W/W]	[Btu/Wh]	[kcal/Wh]	P1	I	Ref. mass flow
[°C]	[°F]	pe	pc	RGT	Tliq							[W]	[A]	[kg/h]
-23	-10	54	32	32	509,6	1740	438,6	1,49	5,08	1,28	342,4	2,73	5,16	ASHRAE LBP
54	130	32	32	90										
-25	-13	55	32	55	380,1	1298	327,1	1,16	3,95	1,00	328,7	2,68	4,73	cecomaf LBP
55	131	32	55	90										
-35	-31	40	20	40	291,4	995	250,7	1,19	4,05	1,02	245,6	2,40	3,33	EN12900 LBP
40	104	20	40	68										
-7	20	54	35	46	907,2	3098	780,7	1,92	6,56	1,65	472,3	3,25	10,35	ASHRAE MBP
54	130	35	46	95										
-10	14	55	32	55	723,8	2472	622,9	1,61	5,49	1,38	450,2	3,16	9,16	cecomaf MBP
55	131	32	55	90										
-10	14	45	20	45	795,4	2717	684,6	1,95	6,68	1,68	406,9	2,97	9,77	EN12900 MBP
45	113	20	45	68										

### Performance tables

R290, 230V/50Hz, RSIR, fan 3m/s, UL, CB

	pe		Cooling capacity			COP	EER	P1			I	m
	[°C]	[°F]	[W]	[Btu/h]	[kcal/h]	[W/W]	[Btu/Wh]	[kcal/Wh]	[W]	[A]	[kg/h]	
[°C / °F]	-25	-13	449,0	1534	386,4	1,43	4,88	1,23	314,5	2,62	5,06	
cond. pressure	-23	-10	483,6	1651	416,2	1,49	5,08	1,28	325,3	2,66	5,46	
pc= 45/113	-15	5	684,1	2336	588,7	1,81	6,18	1,56	377,7	2,85	7,78	
return gas temp.	-9	15	845,2	2887	727,4	2,06	7,04	1,77	410,0	2,98	9,68	
RGT= 32/90	-4	25	1030,0	3518	886,5	2,34	8,01	2,02	439,3	3,10	11,88	
liquid temp	0	32	1174,2	4010	1010,5	2,57	8,77	2,21	457,4	3,18	13,62	
Tliq= 45/113	7,2	45	1476,2	5041	1270,4	3,04	10,39	2,62	485,1	3,30	17,34	
[°C / °F]	-25	-13	380,1	1298	327,1	1,16	3,95	1,00	328,7	2,68	4,73	
cond. pressure	-23	-10	412,1	1407	354,6	1,20	4,11	1,03	342,8	2,73	5,14	
pc= 55/131	-15	5	594,7	2031	511,8	1,45	4,94	1,24	411,4	3,00	7,48	
return gas temp	-9	15	739,1	2524	636,1	1,63	5,56	1,40	454,3	3,18	9,36	
RGT= 32/90	-4	25	903,3	3085	777,4	1,83	6,25	1,57	494,0	3,35	11,53	
liquid temp	0	32	1030,7	3520	887,0	1,98	6,78	1,71	519,3	3,46	13,24	
Tliq= 55/131	7,2	45	1296,5	4428	1115,7	2,31	7,91	1,99	560,1	3,65	16,89	



## Model

Designation	<b>NLE10CNT</b>	<b>208-230V/60Hz</b>	<b>Conf. 4</b>	Sales code:	<b>105H6179</b>
-------------	-----------------	----------------------	----------------	-------------	-----------------

## Configuration

Motorconfiguration	RSCR	
Power supply (nominal)	208-230V/60Hz 1~	
Refrigerant	R290	
Application	LBP+MBP	
Voltage range	187-253V	
Starting torque	LST	
Approvals	UL	SA3693
	CB	

## Electrical accessories / wiring diagram

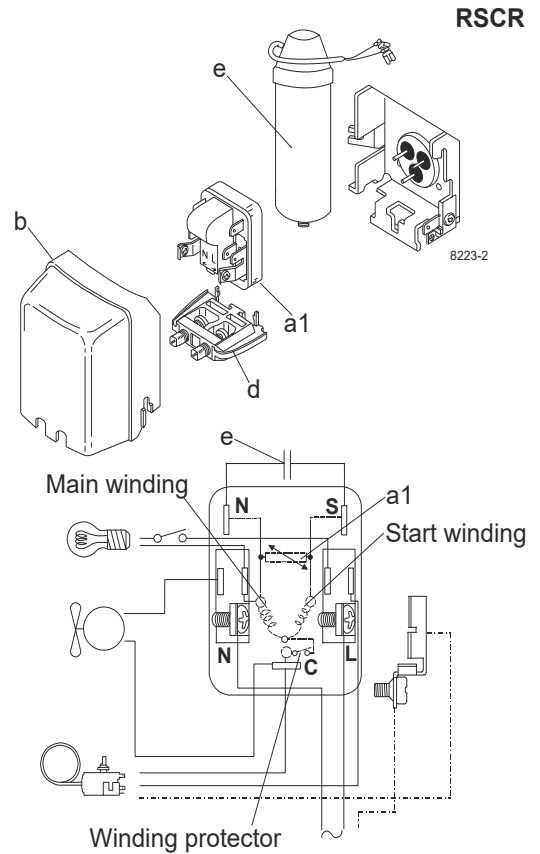

## Ambient/ machine room temperatures minimum /maximum

Ambient temperature range:	10 - 43°C / 50 - 110°F
Machine room temperature range:	10 - 48°C / 50 - 119°F
Compressor cooling:	fan 3m/s

## Operation pressure range

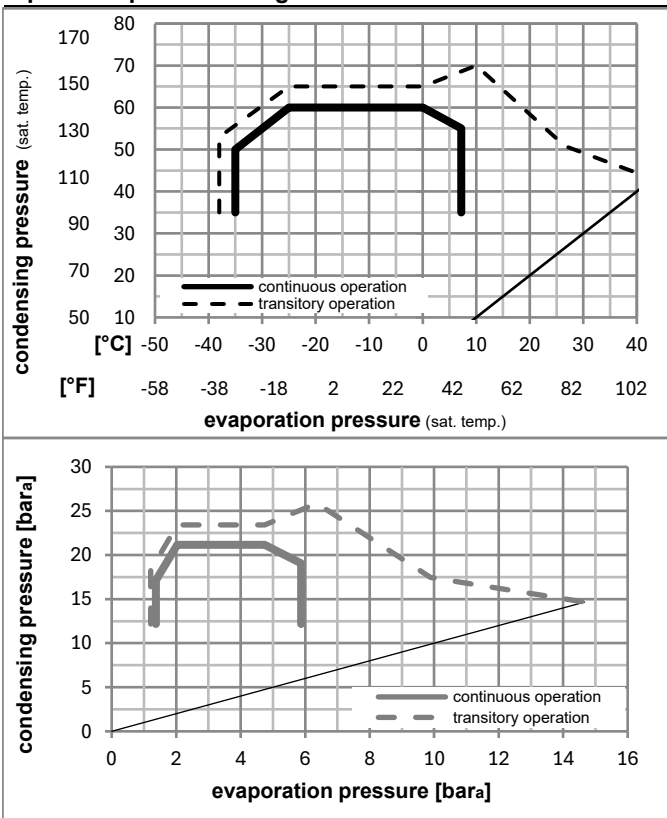

## Components

a1	e-PTC starter (220V, 250hm, 4.8mm)	103N0050
e	run capacitor (4μF, 4.8mm)	117-7119
b	plastic cover	103N2011
d	cord relief	103N1010
	bracket for run capacitor	117-0300
	screw M4x8mm	117-0301

## Model

Designation	<b>NLE10CNT</b>	<b>208-230V/60Hz</b>	<b>Conf. 4</b>	Sales code:	<b>105H6179</b>
-------------	-----------------	----------------------	----------------	-------------	-----------------

## Optimization + standard conditions

R290, 230V/60Hz, RSCR, fan 3m/s, UL, CB

	Evaporating pressure (saturation temperature)				Cooling capacity			COP	EER	P1	Power consumption		Ref. mass flow	
	pe	pc	RGT	Tliq	[W]	[Btu/h]	[kcal/h]				[W]	I		
	[°C]	[°C]	[°C]	[°C]	[W]	[Btu/h]	[kcal/h]	[W/W]	[Btu/Wh]	[kcal/Wh]	[W]	[A]	[kg/h]	
	-23	54	32	32	614,9	2100	529,2	1,72	5,87	1,48	358,1	2,09	6,23	ASHRAE LBP
	[°F]	-10	130	90										
	-25	55	32	55	458,7	1567	394,8	1,33	4,55	1,15	344,0	2,05	5,71	cecomaf LBP
	[°F]	-13	131	90										
	-35	40	20	40	351,7	1201	302,7	1,36	4,64	1,17	258,9	1,83	4,02	EN12900 LBP
	[°F]	-31	104	68										
	-7	54	35	46	1094,0	3736	941,5	2,21	7,55	1,90	494,7	2,51	12,48	ASHRAE MBP
	[°F]	20	130	95										
	-10	55	32	55	872,8	2981	751,2	1,85	6,33	1,59	470,9	2,44	11,04	cecomaf MBP
	[°F]	14	131	90										
	-10	45	20	45	961,2	3283	827,2	2,23	7,61	1,92	431,3	2,30	11,80	EN12900 MBP
	[°F]	14	113	68										

## Performance tables

R290, 230V/60Hz, RSCR, fan 3m/s, UL, CB

	pe		Cooling capacity			COP	EER	P1	I	m	
	[°C]	[°F]	[W]	[Btu/h]	[kcal/h]						
[°C / °F]	-35	-31	335,0	1144	288,3	1,28	4,37	1,10	262,0	1,84	3,75
cond. pressure	-23	-10	584,8	1997	503,3	1,70	5,82	1,47	343,1	2,04	6,60
pc= 45/113	-15	5	826,9	2824	711,7	2,07	7,07	1,78	399,6	2,21	9,41
return gas temp.	-9	15	1021,3	3488	879,0	2,35	8,02	2,02	434,7	2,31	11,69
RGT= 32/90	-4	25	1244,2	4249	1070,8	2,67	9,11	2,30	466,4	2,41	14,35
liquid temp	0	32	1418,1	4843	1220,4	2,92	9,96	2,51	486,1	2,48	16,45
Tliq= 45/113	7,2	45	1782,5	6087	1534,0	3,46	11,80	2,97	515,8	2,58	20,94
[°C / °F]	-35	-31	261,7	894	225,2	1,02	3,47	0,87	257,8	1,82	3,24
cond. pressure	-23	-10	497,2	1698	427,9	1,39	4,74	1,19	358,5	2,09	6,20
pc= 55/131	-15	5	717,2	2449	617,3	1,67	5,70	1,44	430,0	2,31	9,02
return gas temp	-9	15	891,3	3044	767,0	1,87	6,40	1,61	475,4	2,45	11,28
RGT= 32/90	-4	25	1089,3	3720	937,5	2,10	7,19	1,81	517,8	2,59	13,90
liquid temp	0	32	1243,1	4246	1069,9	2,28	7,79	1,96	545,1	2,69	15,97
Tliq= 55/131	7,2	45	1564,4	5343	1346,4	2,65	9,06	2,28	589,4	2,84	20,38

## Model

Designation **NLE10CNT** **220-230V/50Hz** Conf. 5 Sales code: **105H6179**

## Configuration

Motorconfiguration RSCR  
 Power supply (nominal) 220-230V/50Hz 1~  
 Refrigerant R290  
 Application LBP+MBP  
 Voltage range 187-242V  
 Starting torque LST  
 Approvals UL SA3693  
 CB

## Electrical accessories / wiring diagram

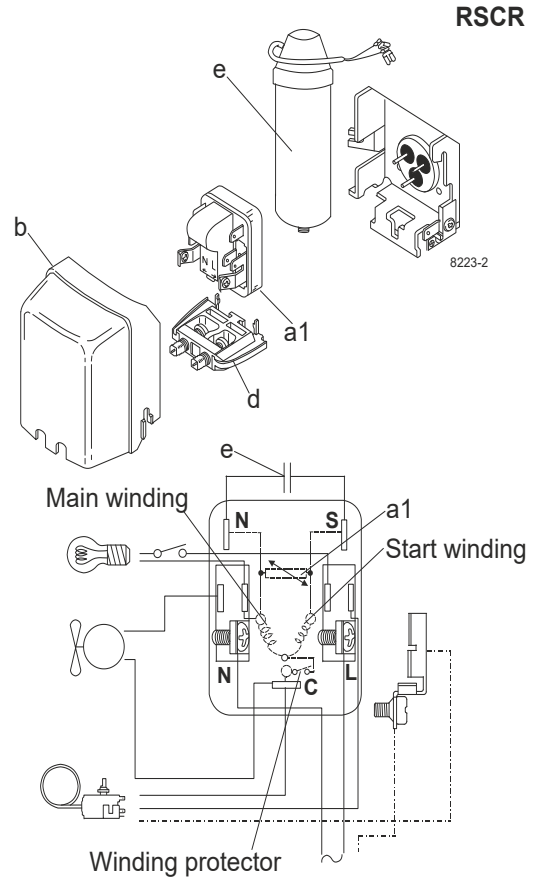

## Ambient/ machine room temperatures minimum /maximum

Ambient temperature range: 10 - 43°C / 50 - 110°F

Machine room temperature range: 10 - 48°C / 50 - 119°F

Compressor cooling: fan 3m/s

## Operation pressure range

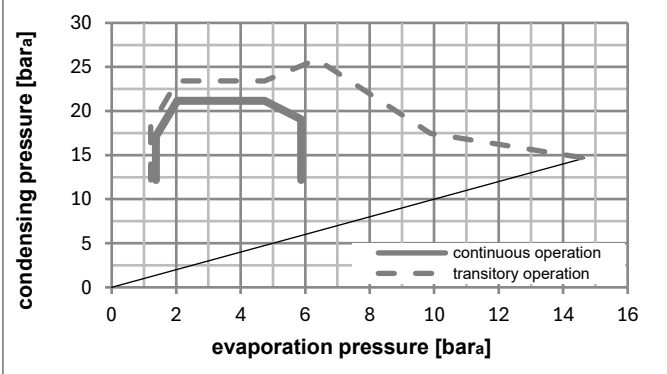
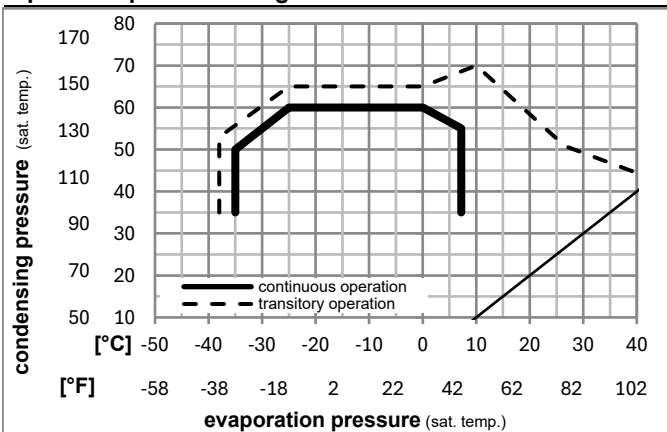

## Components

a1	e-PTC starter (220V, 250hm, 4.8mm)	103N0050
e	run capacitor (4μF, 4.8mm)	117-7119
b	plastic cover	103N2011
d	cord relief	103N1010
	bracket for run capacitor	117-0300
	screw M4x8mm	117-0301

### Model

Designation	<b>NLE10CNT</b>	<b>220-230V/50Hz</b>	<b>Conf. 5</b>	Sales code:	<b>105H6179</b>
-------------	-----------------	----------------------	----------------	-------------	-----------------

### Optimization + standard conditions

R290, 230V/50Hz, RSCR, fan 3m/s, UL, CB

	Evaporating pressure (saturation temperature)				Cooling capacity			COP	EER	P1	Power consumption		ASHRAE LBP	
	pe	pc	RGT	Tliq	[W]	[Btu/h]	[kcal/h]				[W]	[A]		[kg/h]
[°C]	-23	54	32	32	518,0	1769	445,8	1,54	5,25	1,32	337,0	2,50	5,25	ASHRAE LBP
[°F]	-10	130	90	90										
[°C]	-25	55	32	55	386,2	1319	332,4	1,19	4,08	1,03	323,2	2,45	4,81	cecomaf LBP
[°F]	-13	131	90	131										
[°C]	-35	40	20	40	296,2	1011	254,9	1,23	4,21	1,06	240,0	2,20	3,38	EN12900 LBP
[°F]	-31	104	68	104										
[°C]	-7	54	35	46	922,8	3151	794,1	1,99	6,79	1,71	464,0	2,98	10,53	ASHRAE MBP
[°F]	20	130	95	115										
[°C]	-10	55	32	55	736,3	2514	633,6	1,66	5,68	1,43	442,8	2,89	9,31	cecomaf MBP
[°F]	14	131	90	131										
[°C]	-10	45	20	45	807,2	2757	694,7	2,04	6,97	1,76	395,5	2,72	9,91	EN12900 MBP
[°F]	14	113	68	113										

### Performance tables

R290, 230V/50Hz, RSCR, fan 3m/s, UL, CB

	pe		Cooling capacity			COP	EER	P1	I	m	
	[°C]	[°F]	[W]	[Btu/h]	[kcal/h]						[W/W]
[°C / °F]	-35	-31	282,5	965	243,1	1,16	3,96	1,00	243,6	2,21	3,17
cond. pressure	-23	-10	490,4	1675	422,0	1,54	5,27	1,33	317,8	2,44	5,54
pc= 45/113	-15	5	694,0	2370	597,2	1,89	6,44	1,62	367,8	2,62	7,90
return gas temp.	-9	15	857,8	2930	738,3	2,15	7,35	1,85	398,4	2,73	9,82
RGT= 32/90	-4	25	1045,8	3571	900,0	2,45	8,38	2,11	426,1	2,84	12,06
liquid temp	0	32	1192,4	4072	1026,2	2,69	9,18	2,31	443,4	2,91	13,83
Tliq= 45/113	7,2	45	1499,3	5120	1290,3	3,19	10,90	2,75	469,8	3,03	17,62
[°C / °F]	-35	-31	219,8	751	189,2	0,93	3,18	0,80	236,0	2,18	2,72
cond. pressure	-23	-10	418,8	1430	360,5	1,24	4,24	1,07	337,4	2,50	5,22
pc= 55/131	-15	5	604,9	2066	520,6	1,49	5,10	1,28	405,1	2,75	7,61
return gas temp	-9	15	751,8	2568	647,0	1,68	5,75	1,45	446,9	2,91	9,52
RGT= 32/90	-4	25	918,7	3138	790,7	1,89	6,47	1,63	485,0	3,07	11,72
liquid temp	0	32	1048,1	3580	902,0	2,06	7,03	1,77	509,2	3,17	13,46
Tliq= 55/131	7,2	45	1317,7	4500	1134,0	2,41	8,21	2,07	547,9	3,34	17,17